

PARTS LIST

AIR-POWERED DOCK LEVELER



ACTUAL PRODUCT MAY NOT APPEAR EXACTLY AS SHOWN



WARNING

Do not operate or service this product unless you have read and fully understand the entire contents of this manual. Failure to do so may result in property damage, bodily injury or death.

BLUE GIANT[®]

MECHANICAL ASSEMBLY

This exploded view displays common components of the leveler.

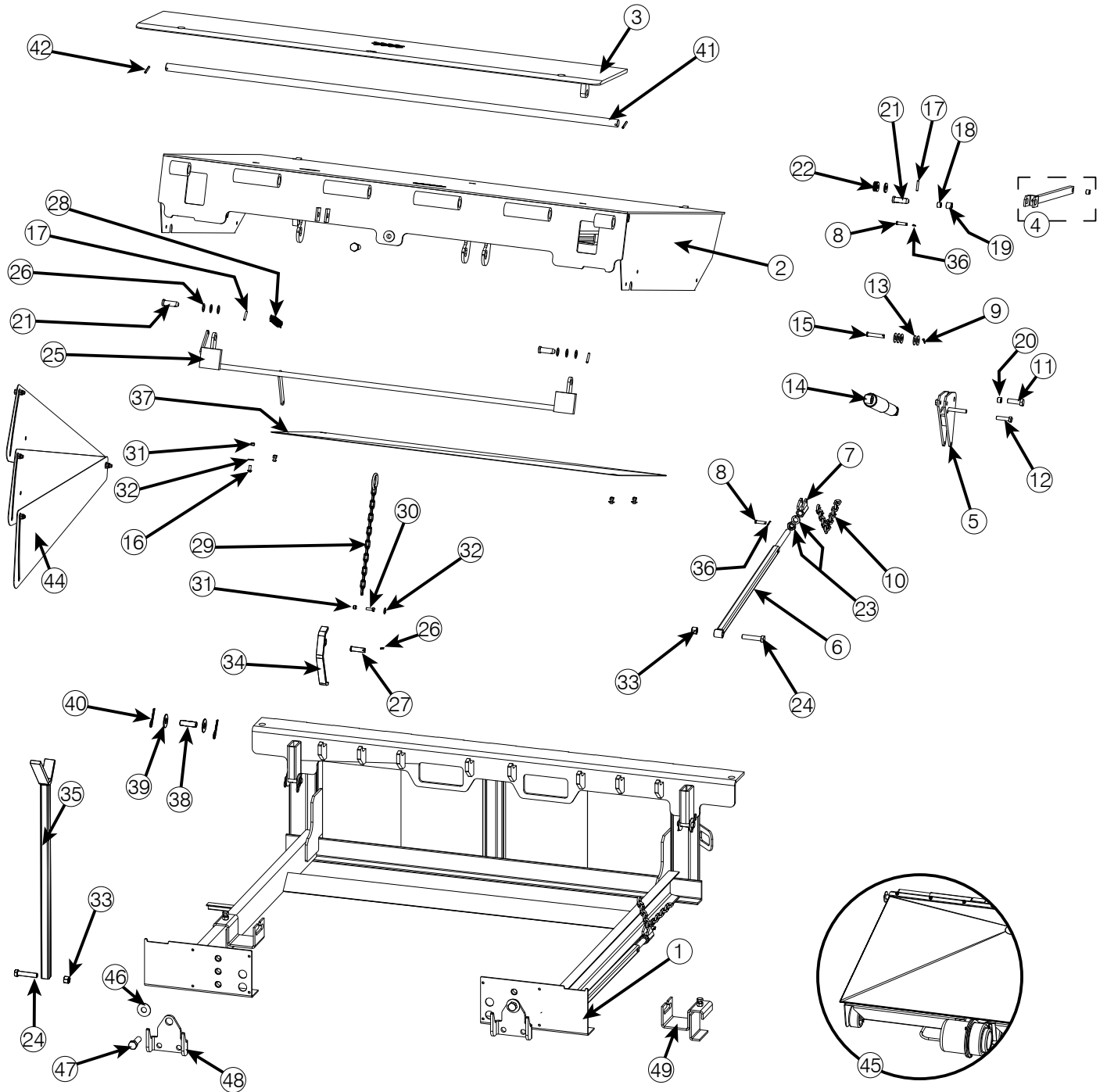

	QTY.	PART NO.	DESCRIPTION
1	1	See Owner's Manual Section "11.7 FRAME SIZE" on page 42	Frame
2	1	See Owner's Manual Section "11.4 DECK SIZE AND CAPACITIES" on page 38	Deck
3	1	See Owner's Manual Section "11.6 LIP SIZE AND CAPACITIES" on page 40	Lip
4	1	2023332-1	Push Rod Assembly W, H, & S models
5	1	1001307	Link Plate Weldment W/ Shock 18-20" Lip
		1001307-1	Link Plate Weldment W/ Shock 16" Lip
6	1	26-011558-1	Lower Link Weldment
7	1	26-011555	Anchor Weldment
8	1	013-542	Clevis Pin
9	3	013-020	Cotter Pin
10	1	26-011305	Chain Assembly (6' L)
		26-011304	Chain Assembly (8' L)
			Chain Assembly (10' L)
11	1	011-032	Hhcs 5/8" - 11 Unc X 2" Gr.5
12	1	010-044	Hhcs 1/2" - 13 Unc X 2"
13	17	012-212	Flat Spacer Washer 1/2" Bolt Size Zinc Plate
14	1	200-02397	Shock Absorber, Hydraulic
15	1	013-171	Clevis Pin, 1/2"Dim X 2-1/2" L
16	1	011-135	5/16" X 3/4 Lg Hex Socket Button Screw
17	3	013-625	Spring Pin
18	1	018-596	Bushing SAE-841 B1012-4
19	1	018-001	Bushing 3/4in ID X 7/8in OD X 3/4in L
20	1	018-005	Bushing Bronze Oilite
21	1	107-196	Clevis Pin 3/4in Od X 1-5/8in L
22	1	2023332	Push Rod Assembly
23A	1	011-530	Hex Jam Nut 3/4" - 10 Unc
23B	1	012-222	Locknut 3/4"
24	2	010-184	Hfbolt0.625-11x3x1.5,Gr8,Preferred
25	1	2000403-1	Fall Safe Legs
26	1	013-066	Split Chain 0.1563x1.25-1
27	1	013-628	Clevis Pin
28	1	017-012	Tension Spring 4 1/2" L
29	1	2000578	Pull Chain
30	1	010-006	Capscrew Hex Head 5/16"
31	1	011-543	Nylon Insert Locknuts 5/16" Nylock
32	1	012-211	Washer Flat 5/16" Bolt Size
33	1	011-501	Nut Hex Lock Nylon Insert Zinc Plated
34	1	2000577	Tilt Bracket Weld

AIR-POWERED DOCK LEVELER—PARTS LIST

	QTY.	PART NO.	DESCRIPTION
35	1	2000659-1	Deck Strut
36	2	013-020	Cotter Pin
37	1	2023292-1	Top Plate (6' L) Top Plate,Ab,57l Deck
		2023292	Top Plate (8' L) Top Plate,Ab,81l Deck
		2023292-2	Top Plate (10' L) Top Plate,Ab,105l Deck
38	2	26-005610	Pin (Rear Fixed Hinge) 3/4" X 2-1/2"
39	4	012-214	Washer,Flat,3/4,Preferred
40	4	013-029	Hairpin Cotter - 11121087
41	1	See "11.5 LIP SHAFT" on page 39	Lip Shaft
42	2	013-012	Spring Pin
44	2	26-013420	Safety Skirt Package (6' L)
		26-013332	Safety Skirt Package (8' L)
		26-013571	Safety Skirt Package (10' L)
45	1	See "11.3 AIRBAG AND PLATFORM ASSEMBLY" on page 36	Air Bag And Platform Assembly
46	2	010-060	Capscrew, Gr5 Zinc Plated for Shipping Only - Discard after install
47	2	012-214	Regular Fw 0.75-6 for Shipping Only - Discard after install
48	2	2000402	Lip Keeper
49	2	2025602	Air Bag Shipping Bracket Assembly

AIRBAG AND PLATFORM ASSEMBLY

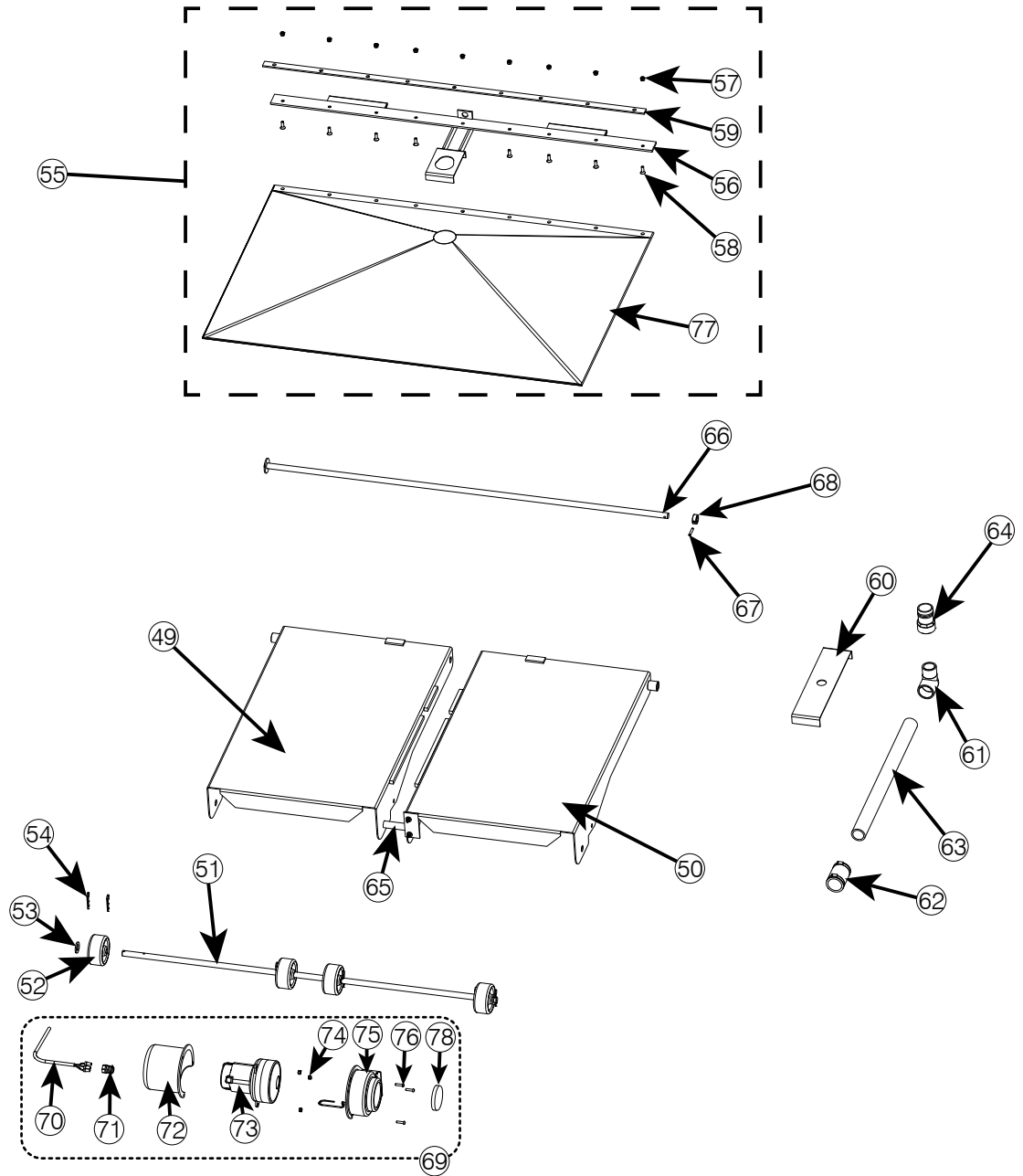

AIR BAG & PLATFORM ASSY - BLOWER MOTOR INCL.

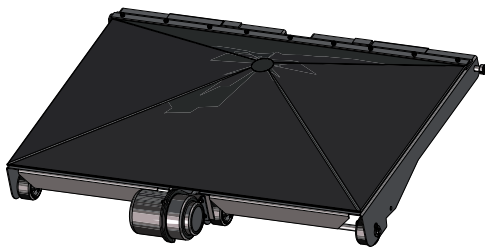

SIZE (LONG)	PART NO.		
	115V	220V	
6'	A	2023295-1	2023295-2
	B	2023295-3	2023295-4
8	A	2023295-5	2023295-6
	B	2023295-7	2023295-8
10	A	2023295-9	2023295-10

A: 18" - 21" Frame B: 22" - 23" Frame

AIR-POWERED DOCK LEVELER—PARTS LIST

ITEM	QTY.	PART NO.		DESCRIPTION		
49	1	18-24in. Frame	22-23in. Frame	LH Platform	6' L	
		2023294-1	2023294-3			8' L
		2023294-5	2023294-7			10' L
50	1	2023294-9		RH Platform	6' L	
		2023294-2	2023294-4			8' L
		2023294-6	2023294-8			10' L
		2023294-10				
51	1	2023301		Wheel Axle		
52	4	020-018		Wheel		
53	2	012-266		WASHER,FLAT,3/4,SAE,3/4ID X 1-1/2OD X 9/64THK,ZINC PLATED		
54	6	013-028		HAIRPIN COTTER, 7/16EYE X 2-9/16		
55	1	26-013428		Air Bag Assembly	6' L	
		26-012959			8' L	
		26-013576			10' L	
56	1	26-012961		Hook Plate		
57	9	011-543		Hex Self Lock Nuts (U.S.)-10 5/16" Nylock Nut		
58	9	011-042		SCHSCREW 0.3125-18x1x1-HX-N-4		
59	1	26-011267		Airbag Clamp Bar		
60	1	26-012978-2		Connector Reinforce Bracket	6' L	
		26-012978-1			8' L	
		26-012978-3			10' L	
61	1	035-096		Elbow Fitting with Barb		
62	1	26-004820		Flex Pipe Coupling		
63	1	091-958-0242		Pipe	6' L	
		091-958-0364			8' L	
		091-958-0440			10' L	
64	1	035-004		Straight Barb		
65	1	090-385-0040		Conduit 3/4x4		
66	1	26-013333		Rear Hinge Pin		
67	1	013-625		Spring Pin		
68	1	26-013415-1		Collar		
69	1	26-012925		Blower Motor Assy 115V / 1PH / 60Hz		
		26-012925-1		Blower Motor Assy 230V / 1PH / 60Hz		
77	1	26-013413		Airbag	6' L	
		26-012962			8' L	
		26-013389			10' L	
ITEM # 69 INCLUDES PARTS LISTED BELOW:						
70	1	091-409-1200		3/C-14 AWG Cable (10' L)		
71	1	025-015		Cable Gland		
72	1	26-013411		Rear Cover		
73	1	031-033		Motor	115V	
		031-034			230V	
74	3	011-545		Nylon Lock Nut		
75	1	26-013412-1		Rib Cover		
76	3	010-224		Round Head Hex Socket Capscrew		
78	1	035-210		Fiberglass Air Filter Pad, 1"Thk		

DECAL IDENTIFICATION AND LOCATION

These labels inform operators and personnel about hazardous areas on and around the dock leveler.

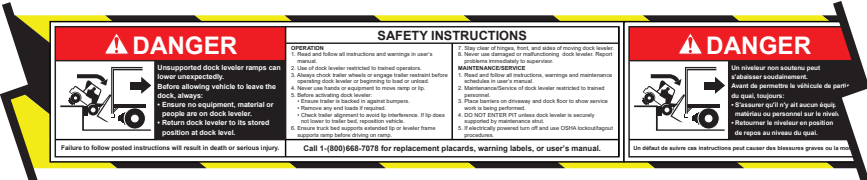
1 

2 

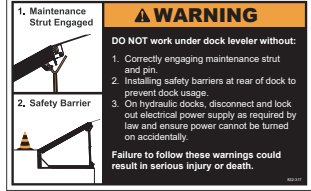
3 

4 

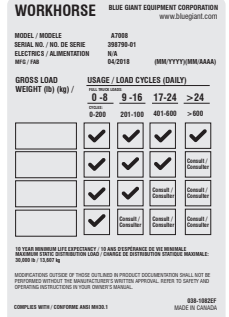
5 

6 

7 

8 

GROSS LOAD WEIGHT (lb) (kg)	USAGE / LOAD CYCLES (DAILY)		
	0-8	9-16	17-24 >24
0-200	251-100	401-600	>600
<input type="checkbox"/>	<input checked="" type="checkbox"/>	<input checked="" type="checkbox"/>	<input checked="" type="checkbox"/>
<input type="checkbox"/>	<input checked="" type="checkbox"/>	<input checked="" type="checkbox"/>	<input checked="" type="checkbox"/>
<input type="checkbox"/>	<input checked="" type="checkbox"/>	<input checked="" type="checkbox"/>	<input checked="" type="checkbox"/>
<input type="checkbox"/>	<input checked="" type="checkbox"/>	<input checked="" type="checkbox"/>	<input checked="" type="checkbox"/>

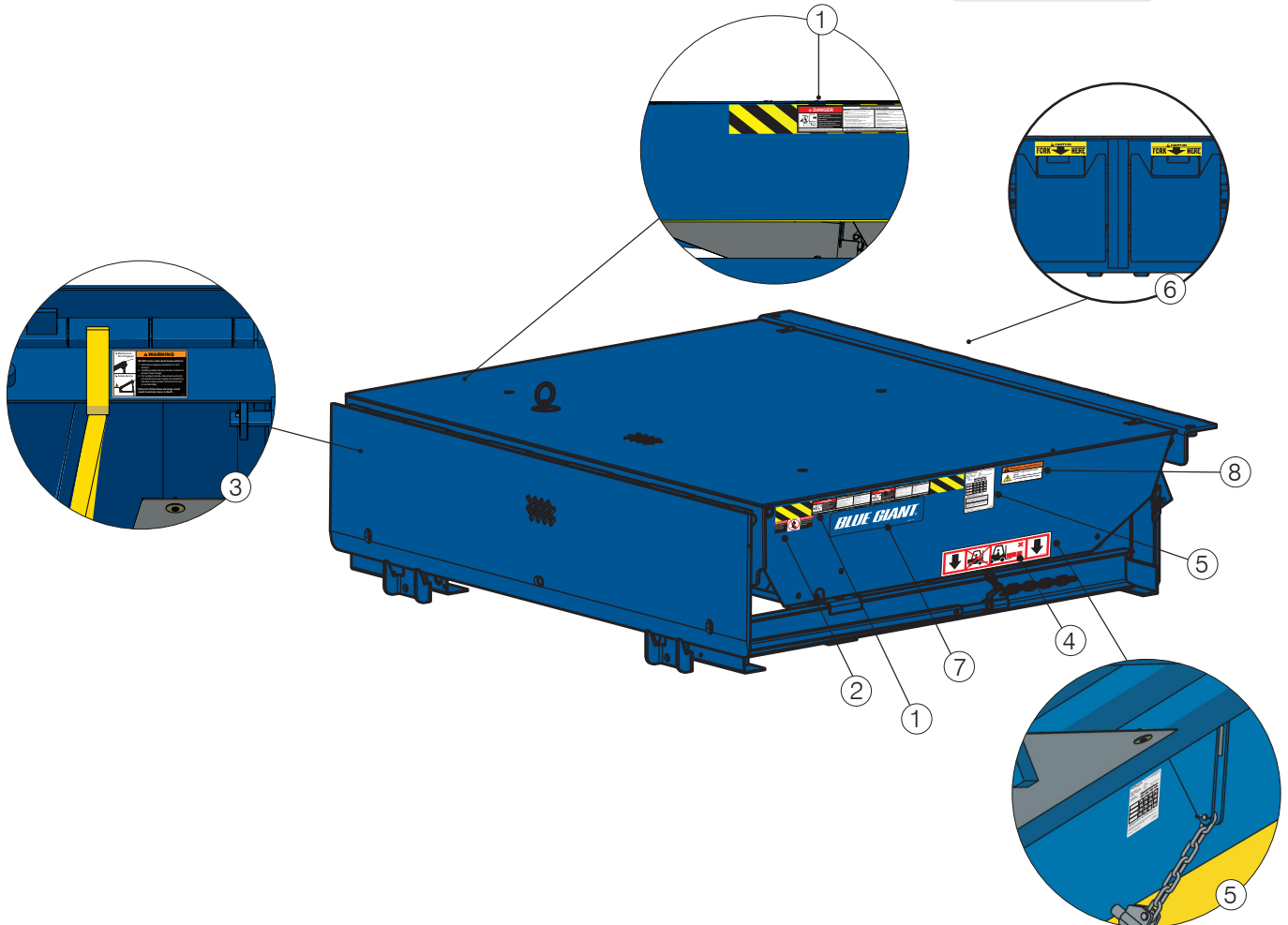

AIR-POWERED DOCK LEVELER—PARTS LIST

ITEM	QTY	PART NO.		DESCRIPTION
1	2	038-226	EF	Danger Decal - Safety Instructions
			ES	
2	2	038-220	EF	Danger Decal - Do Not Walk on Lip
			ES	
3	1	832-317		Warning Decal - Maintenance Strut
4	2	038-1047		Warning Decal - Do Not Lift on This Side
5	2	038-1082	EF	Serial Plate Decal
			ES	
6	2	038-098		Lift Caution Decal
7	2	038-017E		Blue Giant Logo Decal
8	2	038-1097ES		Proposition 65 Decal (as required)

EF = English / French | ES = English / Spanish

RECOMMENDED SPARE PARTS – STANDARD OPERATIONAL COMPONENTS

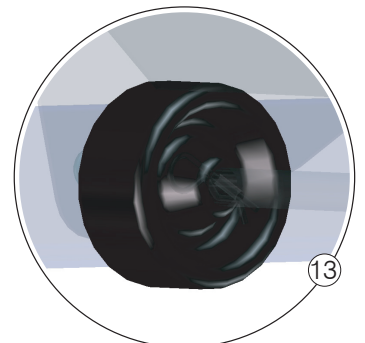
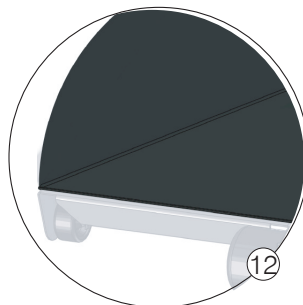
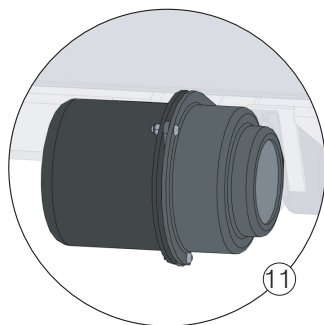
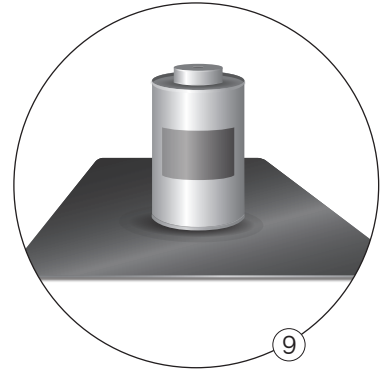
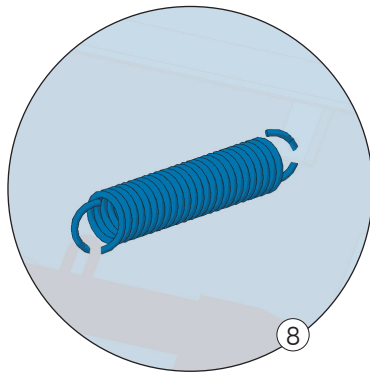
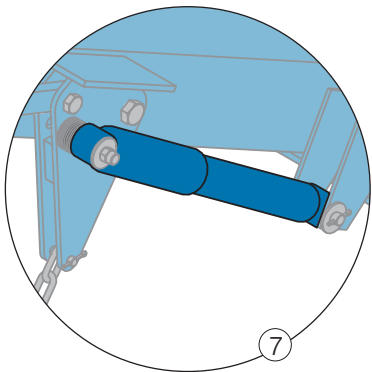
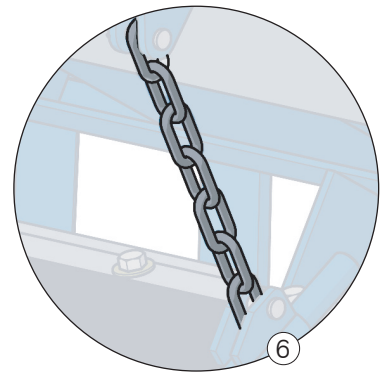
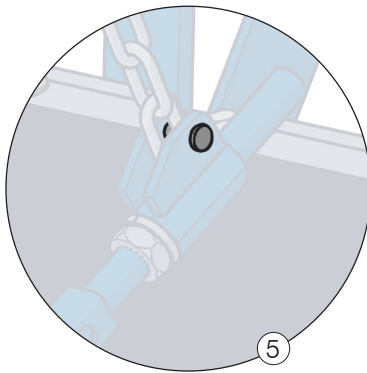
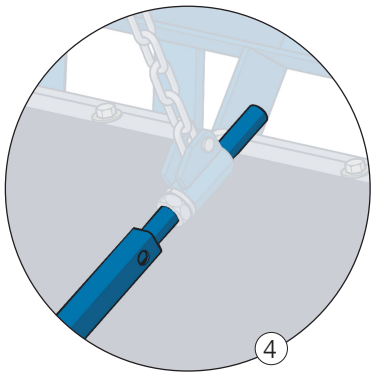
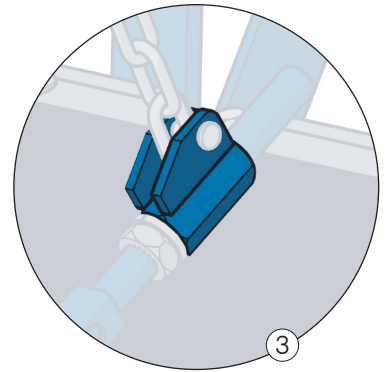
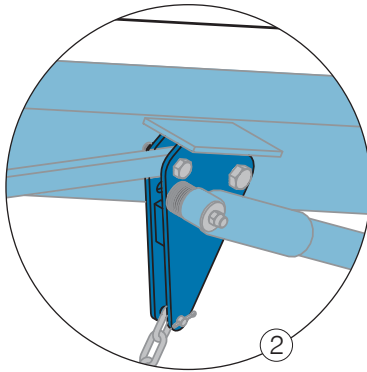
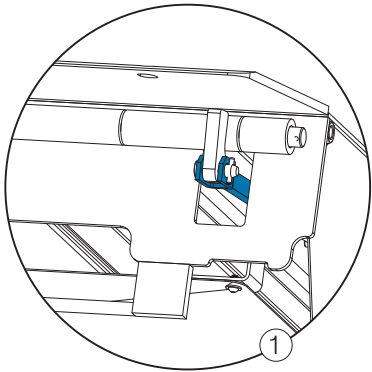

AIR-POWERED DOCK LEVELER—PARTS LIST

REPLACEMENT PARTS Dock Leveler DOCK LEVELER								
ITEM	PART NO.	DESCRIPTION	QTY REQ'D	ITEM	PART NO.	DESCRIPTION	QTY REQ'D	
1	20233325	Push Rod, Lip Deploy	1	9	080-900-1	Patch Kit (includes 1 pc of 60" x 36" vinyl and glue)	1	
2	100137, 1001307-1	Link Plate, Lip Deploy	1	10	R2-40026-1200	Power Cable - 10' L (* Optional)	1	
3	26-011555	Lip Deploy	1	11	Blower Motor (1PH / 60Hz) Only		1	
4	26-011558-1	Lower Link Weldment	1		26-012925	115V		See Section AIRBAG AND PLATFORM ASSEMBLY for breakdown of parts included
5	013-542	Pin 3/8" Dia. x 1-3/8", Lip Deploy	2		26-012925-1	230V		
6	26-011305	Chain Assembly (6' L)	1	12	26-013413	Airbag	6' L	1
	26-011304	Chain Assembly (8 & 10') L	1		26-012962		8' L	
7	200-02397	Shock Absorber	1		26-013389		10' L	
8	017-012	Tension Spring, Fall-Safe	1	13	020-018	Polypropylene Wheel	4	

OPTIONAL SUPPORT COMPONENTS

OPTIONAL SUPPORT COMPONENTS FOR Dock Leveler DOCK LEVELER			
ITEM	PART NO.	DESCRIPTION	QTY REQ'D
14	26-011563	Maintenance Holder for Tray and Bag	1

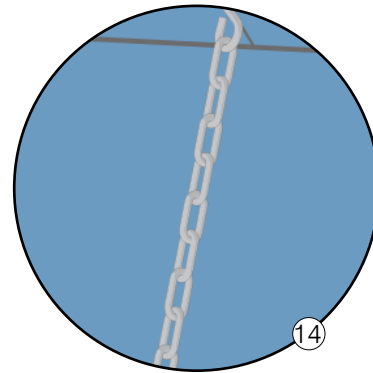

BLUE GIANT[®]
BLUE GIANT EQUIPMENT CORPORATION

Corporate 410 Admiral Blvd
Mississauga, ON, Canada L5T 2N6
t 905.457.3900 f 905.457.2313

USA 6350 Burnt Poplar Road
Greensboro, NC 27409
www.bluegiant.com