

OWNER'S MANUAL

STRONGARM™ ML10 VEHICLE RESTRAINT



ACTUAL PRODUCT MAY NOT APPEAR EXACTLY AS SHOWN

WARNING

Do not operate or service this product unless you have read and fully understand the entire contents of this manual. Failure to do so may result in property damage, bodily injury or death.

BLUE GIANT

TABLE OF CONTENTS

1.0	ABOUT THE STRONGARM™ ML10 WITH OPTIONAL TLC24 CONTROLS	3
1.1	OWNER'S PURCHASE RECORD	3
2.0	INTRODUCTION	4
2.1	WARRANTY INFORMATION	4
2.2	EXCLUSION OF LIABILITY	4
2.3	MANUFACTURER'S NOTE	4
2.4	OWNER'S RESPONSIBILITY	5
3.0	SAFETY MESSAGE COLOR IDENTIFICATION	6
3.1	OPERATIONAL SAFETY WARNINGS	6
4.0	LOCKOUT / TAGOUT PROCEDURE AND RULES	7
5.0	OPERATING INSTRUCTIONS - STANDALONE STRONGARM™ ML10	8
5.1	FUNCTIONAL DESCRIPTION	8
5.2	PRIOR TO USE: EQUIPMENT IN HOME POSITION	9
5.3	TRAILER AT BAY	9
5.4	ENGAGING RESTRAINT	9
5.5	RELEASING THE RESTRAINT ARM	10
6.0	PLANNED MAINTENANCE (PM) CHECK LIST – VEHICLE RESTRAINT – BASED ON CYCLES	11
7.0	RECOMMENDED SPARE PARTS	12
7.1	STANDARD OPERATIONAL COMPONENTS	12
7.2	PROTECTIVE COMPONENTS	13
7.3	TLC24 COMPONENTS (OPTIONAL)	13
8.0	DECAL IDENTIFICATION AND LOCATION	14
9.0	EQUIPMENT COMPONENT ILLUSTRATIONS	15
9.1	COMPONENTS AS SHIPPED CHECKLIST	15
9.2	MECHANICAL ASSEMBLY - 52-011130 / 52-011130-ZP	16
9.3	GENERAL DIMENSIONS	17
10.0	OPERATING INSTRUCTIONS - STRONGARM™ ML10 WITH TLC24 CONTROLS (AUTOMATIC & MANUAL)	18
10.1	PRIOR TO USE: EQUIPMENT IN HOME POSITION	18
10.2	TRAILER AT BAY	18
10.3	ENGAGING RESTRAINT	19
10.4	RELEASING THE RESTRAINT ARM	19
10.5	MANUAL OVERRIDE MODE (TLC24-A)	20
10.6	TLC24 CONTROLS	21
11.0	OPERATING INSTRUCTIONS - STRONGARM™ ML10 WITH BLUE GENIUS™ CONTROLS	22
11.1	TRAILER AT BAY	22
11.2	ENGAGING RESTRAINT	22
11.3	RELEASING THE RESTRAINT ARM	23
11.4	MANUAL OVERRIDE MODE	23
11.5	BLUE GENIUS™ CONTROLS	24
12.0	EXTERIOR TRAFFIC LIGHT / MIRROR IMAGE SIGN	25
13.0	VEHICLE RESTRAINT TROUBLESHOOTING	26
14.0	WIRING DIAGRAMS	27
14.1	WIRING DIAGRAM—TLC24-A 115V AND 230V SINGLE PHASE	28
14.2	WIRING DIAGRAM—TLC24-M 115V AND 230V SINGLE PHASE	29
14.3	WIRING DIAGRAM— BLUE GENIUS™ 115V SINGLE PHASE	30

1.0 ABOUT THE STRONGARM™ ML10 WITH OPTIONAL TLC24 CONTROLS

The StrongArm™ ML10 Mechanical Vehicle Restraint is a high-performance yet low-cost solution for loading docks worldwide. With a vertical restraining range of 11" to 26" (279 mm to 660 mm) above ground and horizontal reach of 13" (330 mm), the ML10 is compatible with virtually all modern trucks and trailers, even those with air-ride suspension systems. 30,000 lb (13,636 kg) of restraining force prevents premature truck departure during loading and unloading. Easy and ergonomic to operate, the unit is engaged and released by a single detachable control rod.

This manual also incorporates operating instructions for the TLC24-A (automatic) and TLC24-M (manual) lights communication packages, which are optional and recommended add-ons to the ML10. Both control stations feature a keyed selector switch, red and green indicator lights, high-visibility LED traffic lights, and mirror-image driver warning signs.

1.1 OWNER'S PURCHASE RECORD

OWNER'S PURCHASE RECORD
Please record information for future inquiries and to validate warranty. (See Section 2.1 for warranty validation)

Dealer:	Date in Service:
	Number of Units:
Serial Number:	Door #:
Serial Number:	Door #:
Serial Number:	Door #:
Serial Number:	Door #:
Serial Number:	Door #:
Serial Number:	Door #:
Serial Number:	Door #:
Serial Number:	Door #:
Serial Number:	Door #:

The manufacturer offers a full line of dock levelers, dock safety equipment, accessories, ergonomic and scissor lift equipment, seals and shelters, and industrial trucks. Concurrent with a continuing product improvement program, specifications are subject to change without notice (see Section 2.2 "Exclusion of Liability"). Please contact the manufacturer for latest information. Some features illustrated may be optional in certain market areas.

NOTICE
See Section 8.0 "Decal Identification and Location," item #4 for serial number location.

2.0 INTRODUCTION

The following is a quick reference to important procedures that must be followed while using the Vehicle Restraint System. It is not intended to cover, or suggest that it does cover, all procedures necessary to ensure safe operation. All operators should be aware of and abide by all workplace safety regulations applicable to the operation of the Vehicle Restraint System. These laws and regulations include but are not limited to:

- The Occupational Safety and Health Act
- Canada Occupational Health and Safety Regulations
- Occupational Safety and Health Acts for Individual States (USA)

For additional information on these regulations as well as industry standards that may apply to this product, please contact:



American National Standards Institute (ANSI)
 1430 Broadway
 New York, NY 10018
 Telephone: 212.642.4900
 www.ansi.org

Also a member of:



Loading Dock Equipment Manufacturers
 A Product Section of Material Handling Industry of America
 A Division of Material Handling Industry
 8720 Red Oak Blvd, Suite 201
 Charlotte, NC, 28217-3992
 Telephone: 704.676.1190
 www.mhi.org/lodem

2.1 WARRANTY INFORMATION

Thank you for purchasing Blue Giant products. We appreciate your business, and are confident that our product will serve you for many years to come. In the event that you experience a problem with our product, our Warranty Center is here to support the Blue Giant Product(s) that you have purchased.

To validate warranty on recently purchased equipment, please complete and submit your information with our online Warranty Registration at www.BlueGiant.com.

For more information about Blue Giant Warranty Support, please contact your local Blue Giant Equipment dealer, representative or authorized partner near you. You may also visit www.BlueGiant.com or phone 1.905.457.3900.

DEALER INFORMATION

Name:

Contact:

Telephone:

* **NOTE:** All products must be registered to qualify for warranty.

2.2 EXCLUSION OF LIABILITY

The manufacturer assumes no liability for damage or injury to persons or property which occur as a result of defects or faults in or incorrect use of the Vehicle Restraint System. The manufacturer also assumes no liability for lost profits, operating downtimes, or similar indirect losses incurred by the purchaser. Injury to third parties, irrespective of its nature, is not subject to compensation.

The manufacturer reserves the right to make changes at any time to the modules, components, and accessories, concurrent with its continuing product improvements and development program. Specifications, operating instructions, and illustrations included in this manual are subject to change without notice. Please contact manufacturer for the latest information.

2.3 MANUFACTURER'S NOTE

The Vehicle Restraint has been carefully inspected and tested at the manufacturer's plant prior to shipment, but should be checked upon receipt for transport damage. Any observed transport damage is to be listed on the signed copy of the freight document. Notify the freight forwarder of any damage WITHIN 48 HOURS.

2.4 OWNER'S RESPONSIBILITY

1. The owner should recognize the inherent danger of the interface between the dock and the freight carrier. The owner should, therefore, train and instruct operators in the safe use of the dock equipment and accessories in accordance with the manufacturer's recommendations.
2. The owner should thoroughly familiarize themselves with the following procedures and specifications, and request immediate replacement of all manufacturer-supplied documents that are missing, damaged, or otherwise illegible.
 - Installation instructions
 - Operating instructions
 - Planned maintenance procedures
 - Inspections procedures
 - Replacement parts lists

Upon receipt of any newly purchased dock equipment, the owner shall verify the presence of owner's manuals, operating placards, and any other documentation necessary for training dock personnel how to use the equipment safely and effectively.



3. Manufacturer's recommended periodic maintenance and inspection procedures shall be followed, and written records of the performance of these procedures should be kept as per warranty guidelines.
4. Dock equipment that is structurally damaged, experiencing performance irregularities, or has been potentially compromised (i.e. sudden loss of support due to premature truck departure) shall be removed from service until a trained and authorized manufacturer's representative can conduct an inspection and perform any necessary repairs.
5. As with any piece of machinery, dock equipment requires routine maintenance, lubrication, and adjustments. Your local Blue Giant® representative offers owners the option of a Planned Maintenance Program (P.M.P). As part of this service, your local Blue Giant representative will do all routine maintenance, lubrication, and adjustments.
6. The owner shall ensure that all nameplates, caution/

instruction markings or labels are in place and legible, and that the appropriate operating/maintenance manuals are provided to authorized users. Replacement name plates, caution/instruction labels, and manuals containing operating and maintenance instructions are available through the Blue Giant Aftermarket Department. See Section 8.0 "*Decal Identification and Location*" for more information.



7. Modifications or alterations of dock equipment shall be made only with written permission of the original manufacturer. These changes shall also satisfy all safety recommendations of the original equipment manufacturer for the particular application of the dock equipment.
8. The owner or a trained and authorized representative shall verify that all freight carrier brakes have been applied and a vehicle restraint and/or wheel chocks properly engaged before cross-docking procedures such as loading and unloading begin.
9. Unless specifically agreed to in writing by Blue Giant Equipment Corporation at the time of order (and prior to manufacture), all Blue Giant Dock equipment is sold as a complete offering, and must not be altered or added to in any manner (which includes configuration and function) without written permission from an authorized manufacturer's representative.
10. If, at the request of the owner, Blue Giant does not supply all or some of the dock equipment power unit and/or control station components, the owner shall assume responsibility for any and all operational and safety issues associated with the resulting configuration.

3.0 SAFETY MESSAGE COLOR IDENTIFICATION

This manual includes color-coded safety messages that clarify instructions and specify areas where potential hazard exists. To prevent the possibility of equipment damage and serious injury or death, please observe strictly the instructions and warnings contained in the messages. If warning decals become damaged or missing, replace them immediately. Avoid accidents by recognizing dangerous procedures or situations before they occur.

 DANGER	NOTICE
Serious injury or death will likely occur if the instructions are not followed.	Procedures marked notice must be followed in order to prevent damage to machinery.
 WARNING	 CAUTION
Serious injury or death may occur if the instructions are not followed.	Instructions marked caution concern safe operating procedure. Failure to comply may result in personal injury.

3.1 OPERATIONAL SAFETY WARNINGS

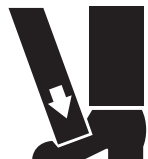
 DANGER	
<p>Keep hands and feet away from operating space of the restraint apparatus.</p> <div style="display: flex; align-items: center; gap: 20px;"> <div style="text-align: center;"> <p>CRUSH HAZARD</p>  </div> <div style="text-align: center;">  </div> </div>	<ol style="list-style-type: none"> 1. Do not operate the dock equipment while anyone is standing in its path. 2. Lift the dock equipment with suitable hoisting equipment only. Do not stand under the dock equipment or any heavy object while it is being hoisted. 3. BEFORE BEGINNING ANY SERVICE PROCEDURES: Disconnect the power and follow all lockout / tagout procedures outlined in this manual.

 WARNING
<ol style="list-style-type: none"> 1. Installation must be performed only by trained and authorized personnel. 2. Prior to installation, place adequate barriers to prevent vehicle traffic from entering the work area. 3. During installation, anchors must be properly torqued to achieve the necessary anchoring strength. DO NOT USE IMPACT DRIVERS. 4. Any electrical work must be performed by qualified personnel only. 5. Do not remove the wheel chocks until loading /unloading is finished and the truck is cleared for departure or the vehicle restraint has been released and the lights have changed to RED inside and GREEN outside.

NOTICE
<ol style="list-style-type: none"> 1. Do not ground welding equipment to any electrical components. 2. Do not allow the drill to go too deeply into the control box, as damage may occur to the control systems. 3. Never use air to blow debris from the control box. Use a vacuum to perform any necessary cleaning. 4. Do not connect green ground lead into control box or junction box until all welding has been completed. 5. If an extension plate / box is required, securely mount it on the restraint with hardware provided before shimming and drilling. 6. Improper adjustments and / or lubrication may cause operational problems with equipment.

 CAUTION
<ol style="list-style-type: none"> 1. Only trained personnel should operate or service this equipment. 2. Do not operate the dock equipment until the transport vehicle is parked against the dock bumpers. 3. Always park the dock equipment after use. 4. Conduct routine inspections and maintenance. Failure to do so could cause equipment damage and or personal injury. 5. Always call your authorized service representative or manufacturer immediately if a malfunction occurs. 6. Always return the restraint arm to the parked position after use.

4.0 LOCKOUT / TAGOUT PROCEDURE AND RULES

In accordance with the rules and regulations of the Occupational Safety and Health Administration (OSHA), all affected employees must be notified that the machine or equipment will be shut down and locked out to perform repair or maintenance work. The work area must be checked to ensure that all personnel have been removed or safely repositioned. The machine or equipment power supply shall be locked in the OFF position or disconnected from the energy source. Blue Giant strongly recommends that only OSHA-approved lockout devices and procedures be utilized.

The energy isolating device must bear a prominent warning tag indicating that work is being done on the equipment and the name of the authorized employee responsible for the lockout. It is mandatory that tagout notices not be susceptible to deterioration or illegibility due to weather conditions or exposure to chemicals and moisture.

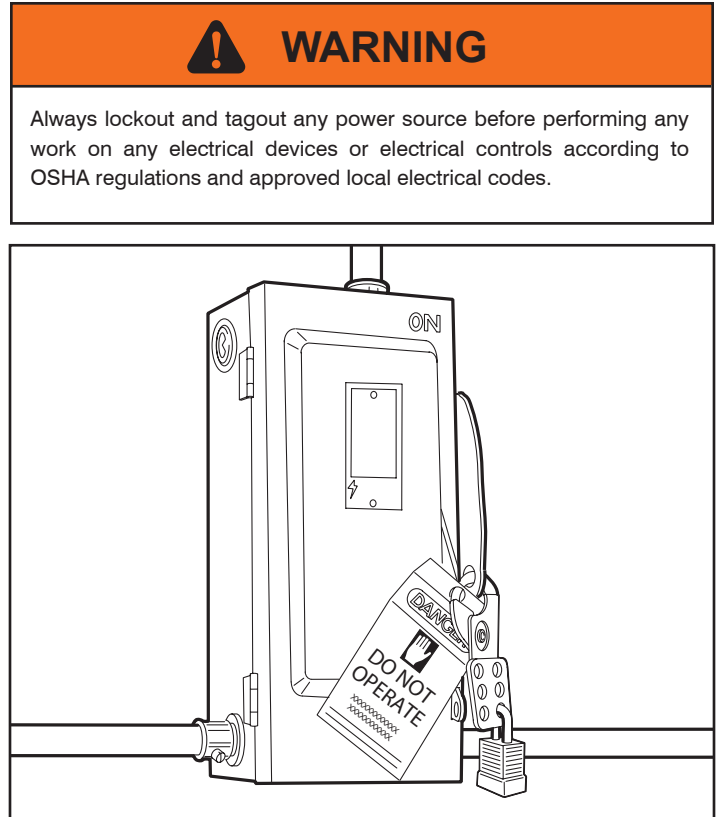

Approved way to lockout / tagout.

5.0 OPERATING INSTRUCTIONS - STANDALONE STRONGARM™ ML10

WARNING

Do not operate this vehicle restraint unless you have been trained and authorized to do so, and have read and understood all of the safety information and instructions contained in this manual.

Do not operate this restraint until you have checked its condition. Report the need for repairs to your supervisor immediately and do not operate the unit until repairs are made.

Never try to lift or move any part of the vehicle restraint manually. Keep hands and feet clear of vehicle restraint pinch points.

It is the responsibility of the owner / operator of truck / vehicle to (whenever possible) exhaust the air from air-ride suspension systems prior to performing loading or unloading. Because ICC bars differ in strength and construction, review the need to use wheel chocks in conjunction with the vehicle restraint.

This vehicle restraint is designed for rear impact guards (RIG) and rear impact protection (ICC Bar) that follow the Federal Motor Carrier Safety Administration guidelines (FMCSA section 571.223 and 571.224) + NHTSA (National Highway Traffic Safety Administration) guidelines.

OPERATING INSTRUCTIONS
Only for the ML10 and TLC24-A (Automatic) or TLC24-M (Manual)

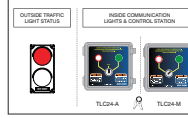

NOTE: The truck / trailer is NOT restrained if the arm is not fully vertical and the communication lights do not change colour as described above. Do a visual inspection to confirm that the ICC bar is securely restrained before proceeding with loading / unloading.

ENGAGE RESTRAINT

Activate the ML10 by using the control rod to press down on the engagement arm until the restraint arm is in the fully vertical position, holding the ICC bar in place.

TLC24-A: The control station light will turn GREEN and the outside traffic light will turn RED.

TLC24-M: Turn the key switch to the 'interlocked' position (green LED). The outside traffic light changes to RED while GREEN light on the control station comes on.

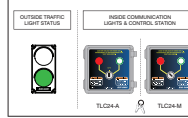

NOTE: If the ICC bar is applying pressure to the restraint arm, it may be necessary to have the driver back up the vehicle before releasing the arm.

RELEASE RESTRAINT

After loading / unloading has been completed and the dock leveler is safely parked, release the restraint arm by pulling up on it quickly and firmly using the control rod. The arm will return to the parked position.

TLC24-A: The control station light will turn RED and the outside traffic light will turn GREEN.

TLC24-M: Turn the key switch to the 'No Traffic' position (red LED). The outside traffic light changes to GREEN and the control station light turns RED.

WARNING

- Only trained and authorized personnel may operate this vehicle restraint.
- Read, understand, and follow the instructions on this document and included manual.
- Prior to using the vehicle restraint:
 - Ensure that the vehicle restraint is free and clear of all debris, snow, and ice.
 - Ensure that all personnel near the vehicle restraint are aware that it is being operated.
 - Operate the vehicle restraint through one complete cycle to confirm that it is functioning properly. If the vehicle restraint is equipped with a communications package, confirm that the lights are working as required.
 - Inspect unit for signs of structural damage or mechanical malfunction. If damage is observed or the restraint fails to operate properly, remove it from service and notify maintenance personnel immediately.
- Before attempting to restrain a transport vehicle:
 - Ensure that the vehicle is parked firmly against the dock bumpers.
 - If the dock leveler is equipped with a light communication package, load and unload on green only.
 - Do not exceed the rated capacity as indicated on the serial plate.
 - Do not leave equipment or material unattended on the dock leveler.
 - Keep a safe distance from both edges.
 - If either the dock leveler or vehicle restraint fail to operate as outlined in the accompanying manual's operating instructions, refer to the Troubleshooting section.
- If service or maintenance is required:
 - Only authorized service personnel shall maintain or service the unit.

APPLIES TO ALL DOCK LEVELER AND VEHICLE RESTRAINT COMBINATIONS

BLUE GIANT www.BlueGiant.com 038-759E Rev.1.1

ML10 operation placard—part # 038-759E.

5.1 FUNCTIONAL DESCRIPTION

The StrongArm™ ML10 mechanical vehicle restraint is used to restrain a trailer at the loading dock. When engaged, it secures a vehicle's under-ride guard (ICC bar), restricting forward movement caused by vehicle creep or unscheduled departure. It is mechanically engaged and disengaged using a control rod (782-371). For added safety, Blue Giant recommends the use of a lights communication package (TLC24-A or TLC24-M) in conjunction with the ML10.

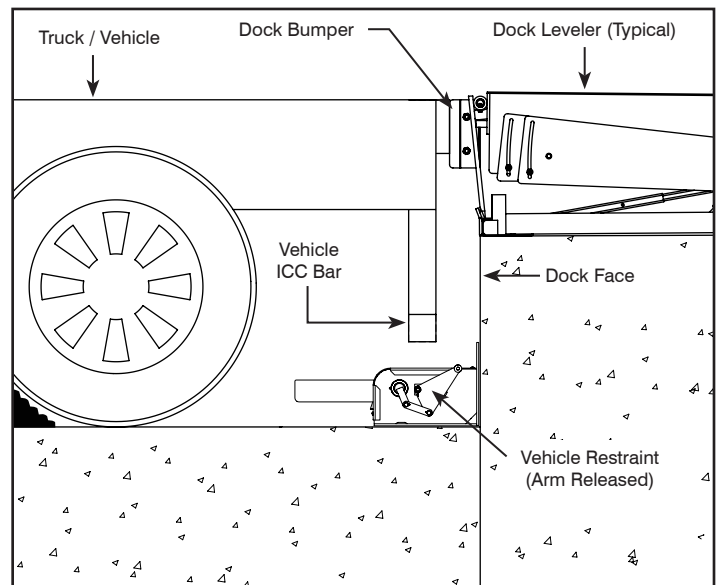

STANDARD OPERATION PROCEDURES

5.2 PRIOR TO USE: EQUIPMENT IN HOME POSITION

The restraint apparatus is in the home position and the dock leveler lip is parked safely in the lip keepers.

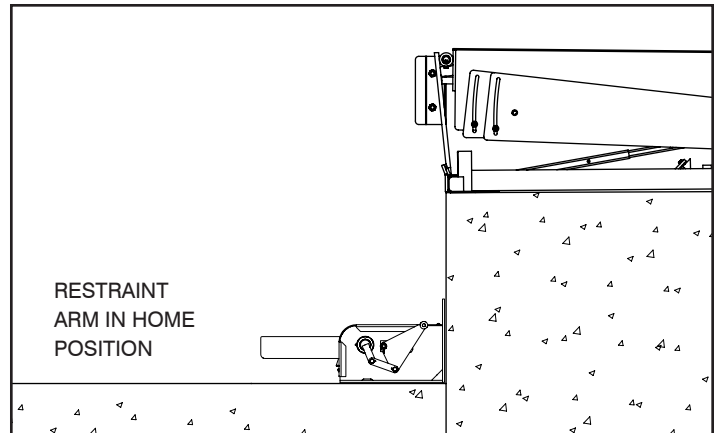

5.3 TRAILER AT BAY

The truck reverses into position against the dock leveler bumpers. After the truck is correctly parked, chock wheels securely.

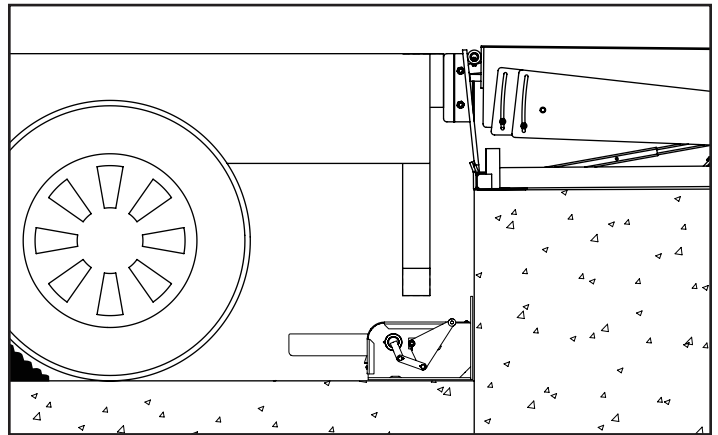

5.4 ENGAGING RESTRAINT

Activate the ML10 by using the control rod (Blue Giant part # 782-371) to press down on the engagement arm until the restraint arm is in the fully vertical locked position, which now holds the ICC bar in place.

NOTE: The truck / trailer is NOT restrained if the arm is not fully vertical. Do a visual inspection to confirm that the ICC bar is securely restrained before proceeding with loading / unloading.

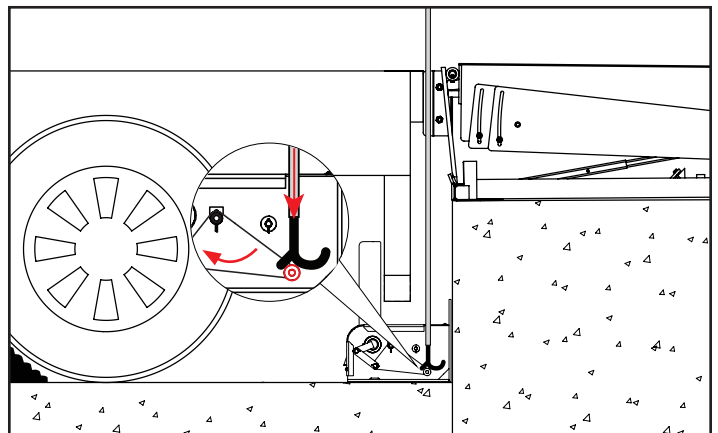

PERFORM LOADING AND UNLOADING

5.5 RELEASING THE RESTRAINT ARM

After loading / unloading has been completed and the dock leveler is safely parked, release the restraint arm by pulling up on it quickly and firmly using the control rod (Blue Giant part # 782-371). The arm will return to the parked position.

NOTE: If the ICC bar is applying pressure to the restraint arm, it may be necessary to have the driver back up the vehicle before releasing the arm.

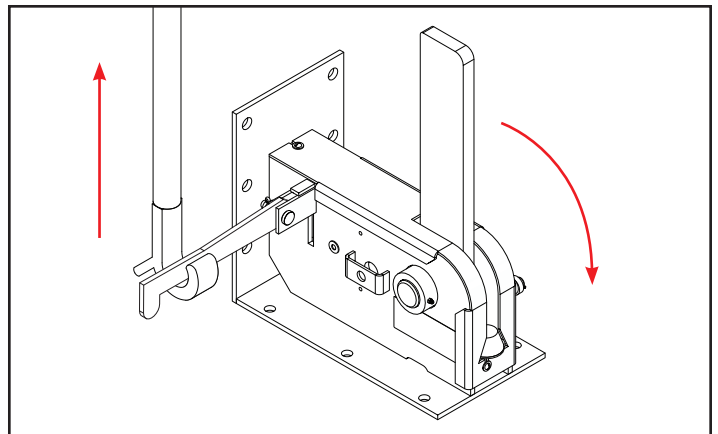
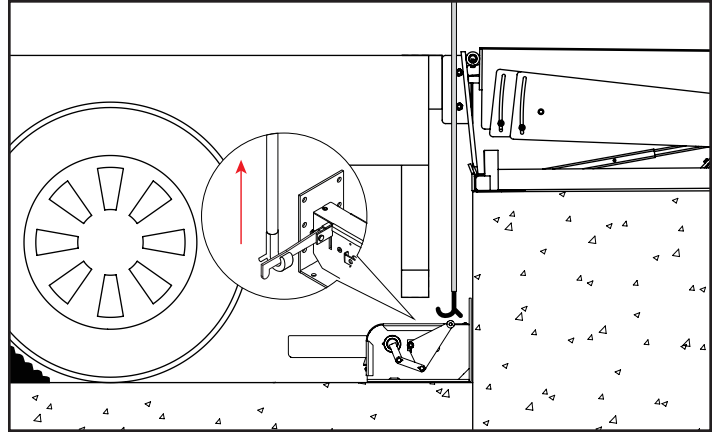

Control rod (part # 782-371) releasing the restraint arm.

6.0 PLANNED MAINTENANCE (PM) CHECK LIST – VEHICLE RESTRAINT – BASED ON CYCLES

INSTRUCTIONS FOR USE: Photocopy this page and indicate “OK for USE” with a check mark ✓ in the appropriate box of each inspection point.

EVERY DAY:

- Remove any debris that may have accumulated inside the restraint.
- Check that the operating hazards placard is present and legible.
- Verify complication-free operation of the restraint and the interior and exterior lights system.
- Check for missing or damaged dock bumpers.
- Verify complication-free operation of the TLC24-A / TLC24-M and exterior lights (if applicable).

EVERY THREE MONTHS:

- Lubricate all bushings.
- Check wall or floor anchors.
- Check safety warning decals and replace if necessary.

Explain faults briefly in the space provided below:

INSPECTED BY: _____ DATE: _____

Forward checklist to the person responsible for Vehicle Restraint maintenance.

 DANGER
When repairing or conducting maintenance procedures on electrical components, perform lockout / tagout steps according to OSHA regulations and approved electrical codes.

 DANGER
Prior to repairs, place adequate barriers to prevent unauthorized personnel and vehicle traffic from entering the work area.

 WARNING
All repairs and maintenance work are to be conducted by trained and authorized personnel ONLY.

7.0 RECOMMENDED SPARE PARTS

7.1 STANDARD OPERATIONAL COMPONENTS

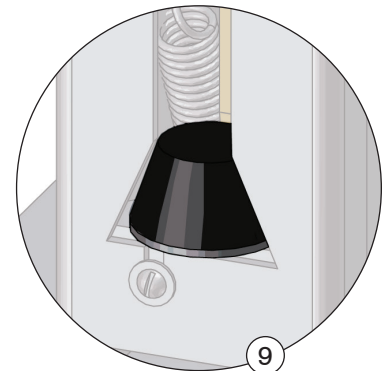
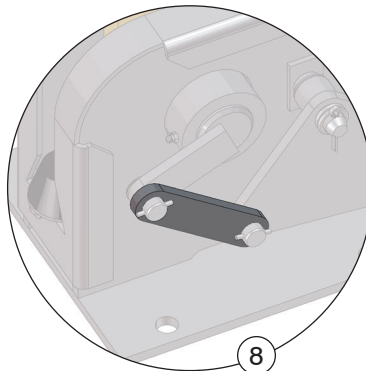
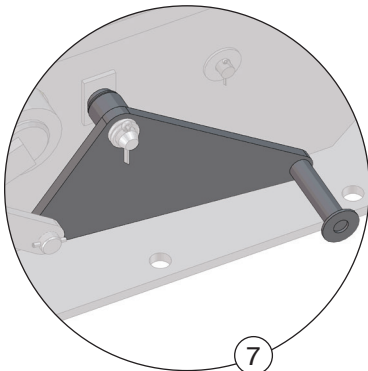
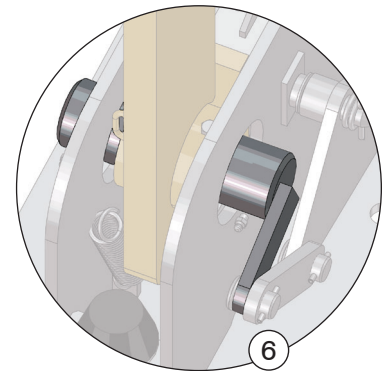
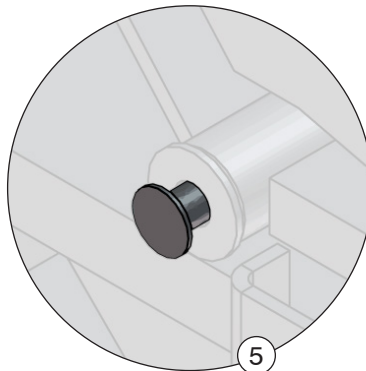
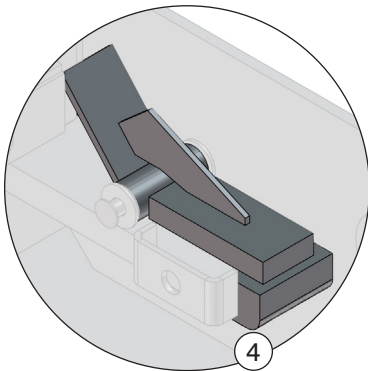
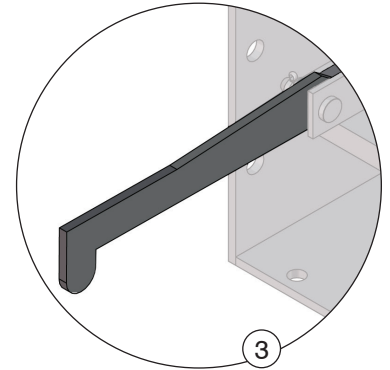
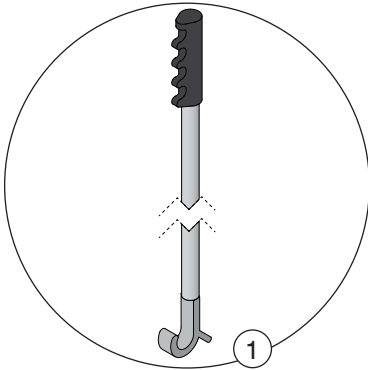

RSP FOR ML10 – STD OPERATIONAL COMPONENTS

ITEM	PART NO.	DESCRIPTION	QTY REQ'D
1	782-371	Control Rod	1
2	017-012	Return Spring	1
3	522-0000	Arm, Release Lever	1
	522-0000-ZP	Arm, Release Lever, Zinc Plated	
4	522-5001	Lock Weldment	1
	522-5001-ZP	Lock Weldment, Zinc Plated	
5	210-0005	Pin, Lock Weldment	1

RSP FOR ML10 – STD OPERATIONAL COMPONENTS

ITEM	PART NO.	DESCRIPTION	QTY REQ'D
6	522-5005	Arm, Pivot Shaft Assembly	1
7	522-5006	Arm, Engagement Lever	1
	522-5006-ZP	Arm, Engagement Lever, Zinc Plated	
8	522-0010	Arm Engagement Link 1 1/4" x 5 5/8" (32mm x 143 mm)	1
	522-0010-ZP	Arm Engagement Link, Zinc Plated 1 1/4" x 5 5/8" (32mm x 143 mm)	
9	091-041	Bumper	1

7.2 PROTECTIVE COMPONENTS

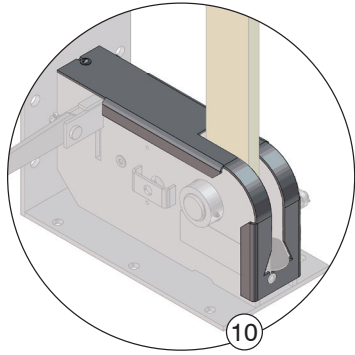

RSP FOR ML10 – PROTECTIVE COMPONENTS			
ITEM	PART NO.	DESCRIPTION	QTY REQ'D
10	52-011187	Top Cover	1
	52-011187-ZP	Top Cover, Zinc Plated	

7.3 TLC24 COMPONENTS (OPTIONAL)

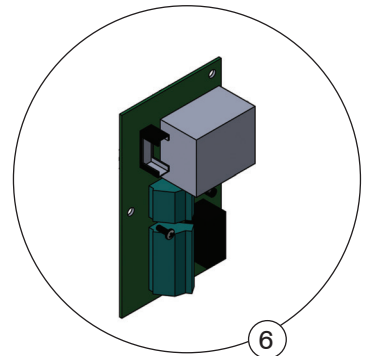
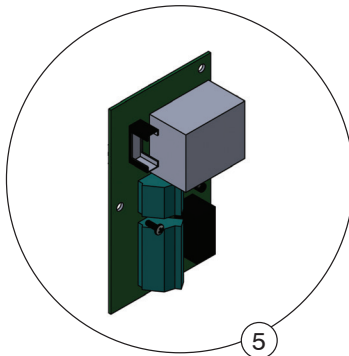
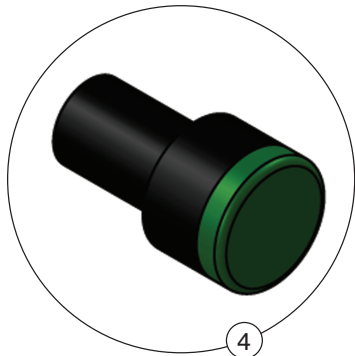
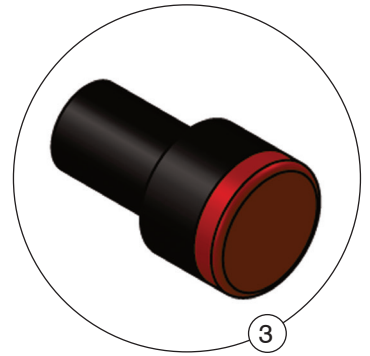
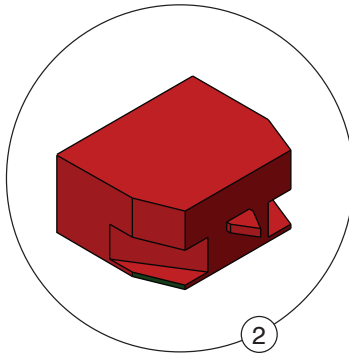
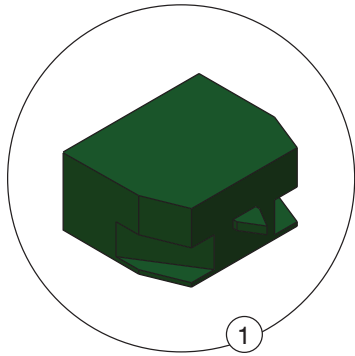

RSP FOR TLC24 COMPONENTS (OPTIONAL)			
ITEM	PART NO.	DESCRIPTION	QTY REQ'D
1	026-G202	Normal-Open Contact Block	1
2	026-G203	Normal-Closed Contact Block	1
3	026-G205	24V Monoblock LED Indicator- Red	1

RSP FOR TLC24 COMPONENTS (OPTIONAL)			
ITEM	PART NO.	DESCRIPTION	QTY REQ'D
4	026-G206	24V Monoblock LED Indicator- Green	1
5	026-G014-1115	Traffic Lights Controller Board (1PH 115V TLC)	1
6	026-G014-1230	Traffic Lights Controller Board (1PH 230V TLC)	1

8.0 DECAL IDENTIFICATION AND LOCATION

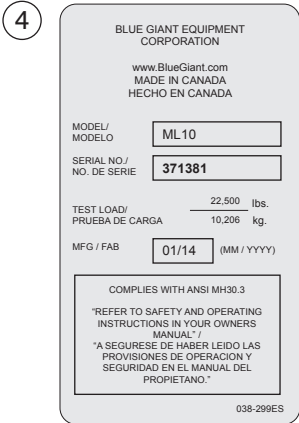
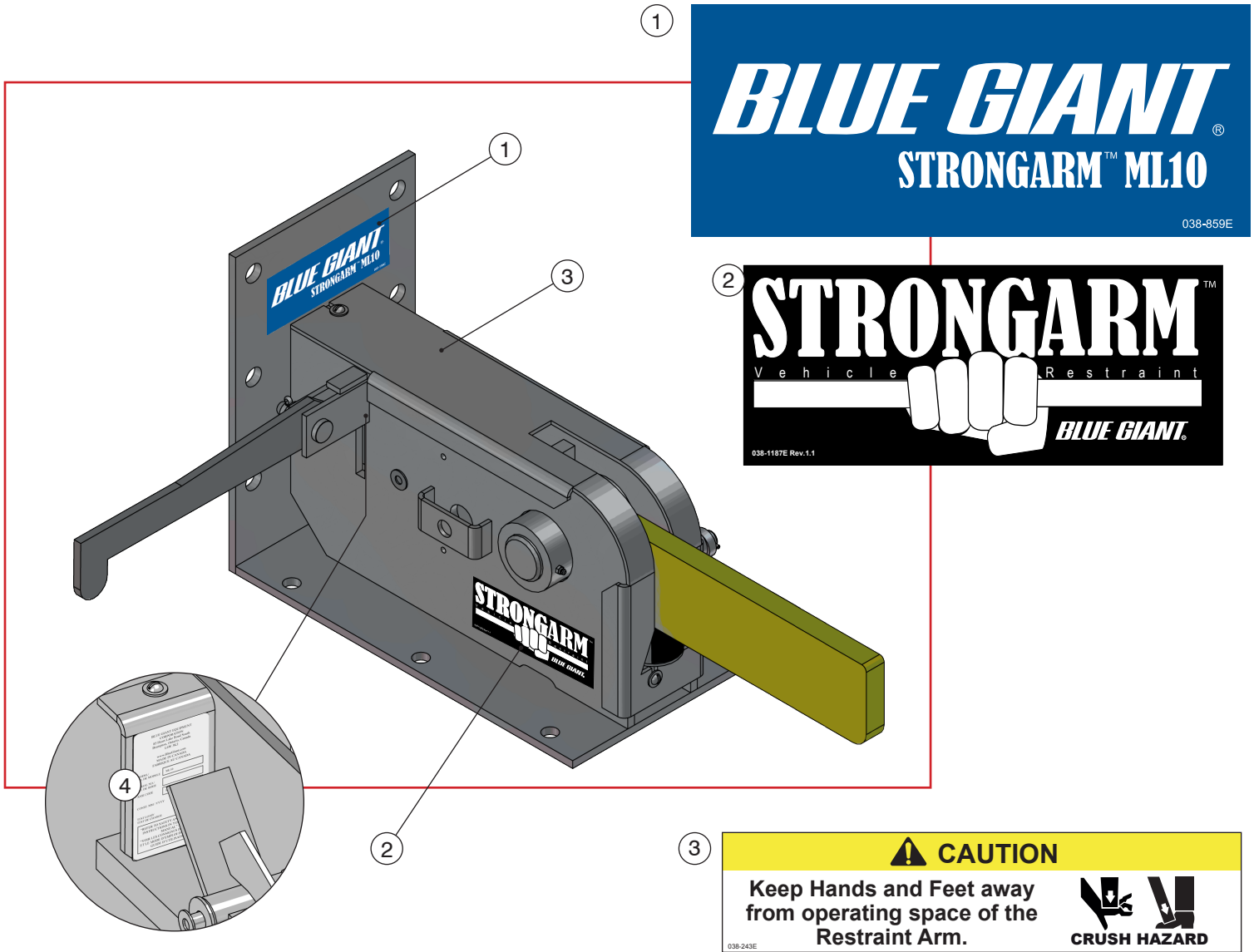

ITEM #	QTY	PART NO.	DESCRIPTION
1	1	038-859E	Decal - BG StrongArm™ ML10
2	1	038-1187E	Decal - StrongArm™ - Vehicle Restraint
3	1	038-243E	Decal - Crush Hazard
4	1	038-299EF	Decal - Serial Plate - English / French
		038-299ES	Decal - Serial Plate - English / Spanish

9.0 EQUIPMENT COMPONENT ILLUSTRATIONS

9.1 COMPONENTS AS SHIPPED CHECKLIST

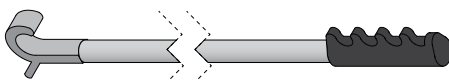
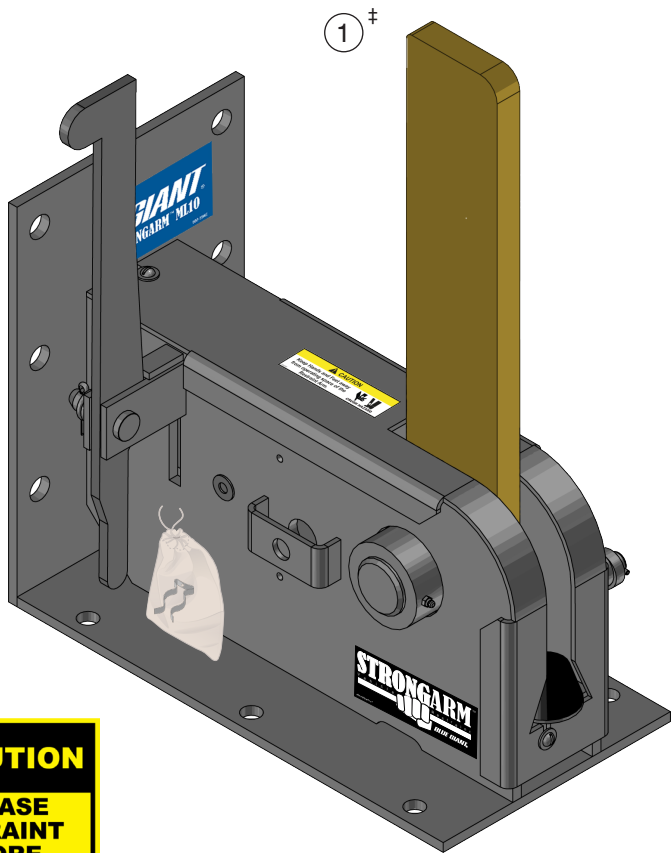

3



‡ NOTE: The arm is shown in the shipping position and will need to be installed correctly.

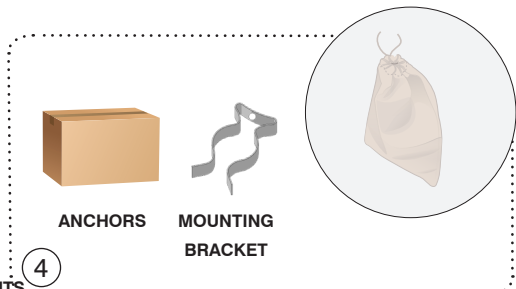

*NOTE: For sign specifications, see Section 7.7

✓	ITEM	QTY	PART NO.	DESCRIPTION	APPROX. WEIGHT	
	1	1	52-011130	ML10 Body	150 lb	68 kg
			52-011130-ZP	ML10 Body, Zinc Plated		
	2	1	038-224/5	E Exterior Driver Warning Sign (English / French / Spanish)	0.7 lb	0.32 kg
		F				
		S				
	3	1	782-371	Control Rod	7 lb	3.2 kg

ITEM # 4 - HARDWARE INCLUDED:

✓	QTY	PART NO.	DESCRIPTION	APPROX. WEIGHT	
	6	010-108	5/8" dia. x 6" / 152mm Anchor Wedge	.15 lb	.06 kg
	1	035-288	Mounting Bracket	—	—

ITEM # 5 - COMPONENTS

✓	QTY	PART NO.	DESCRIPTION	APPROX. WEIGHT	
	1	038-538E	ML10 Owner's Manual	—	—
	1	038-759E	Operation Placard	—	—
	1	038-538E1	ML10 Installaion Manual	—	—

ITEM # 5 - CONTROLS (OPTIONAL)

	1	TLC24-A See Sec 10.0	Automatic Lights Communication Package (optional)	5 lb	2.27 kg
		TLC24-M See Sec 10.0	Manual Lights Communication Package (optional)		
	1	032-806	Exterior Traffic Light (optional)	1.3 lb	0.6 kg
	1	038-759E	Operation Placard	—	—

9.2 MECHANICAL ASSEMBLY - 52-011130 / 52-011130-ZP

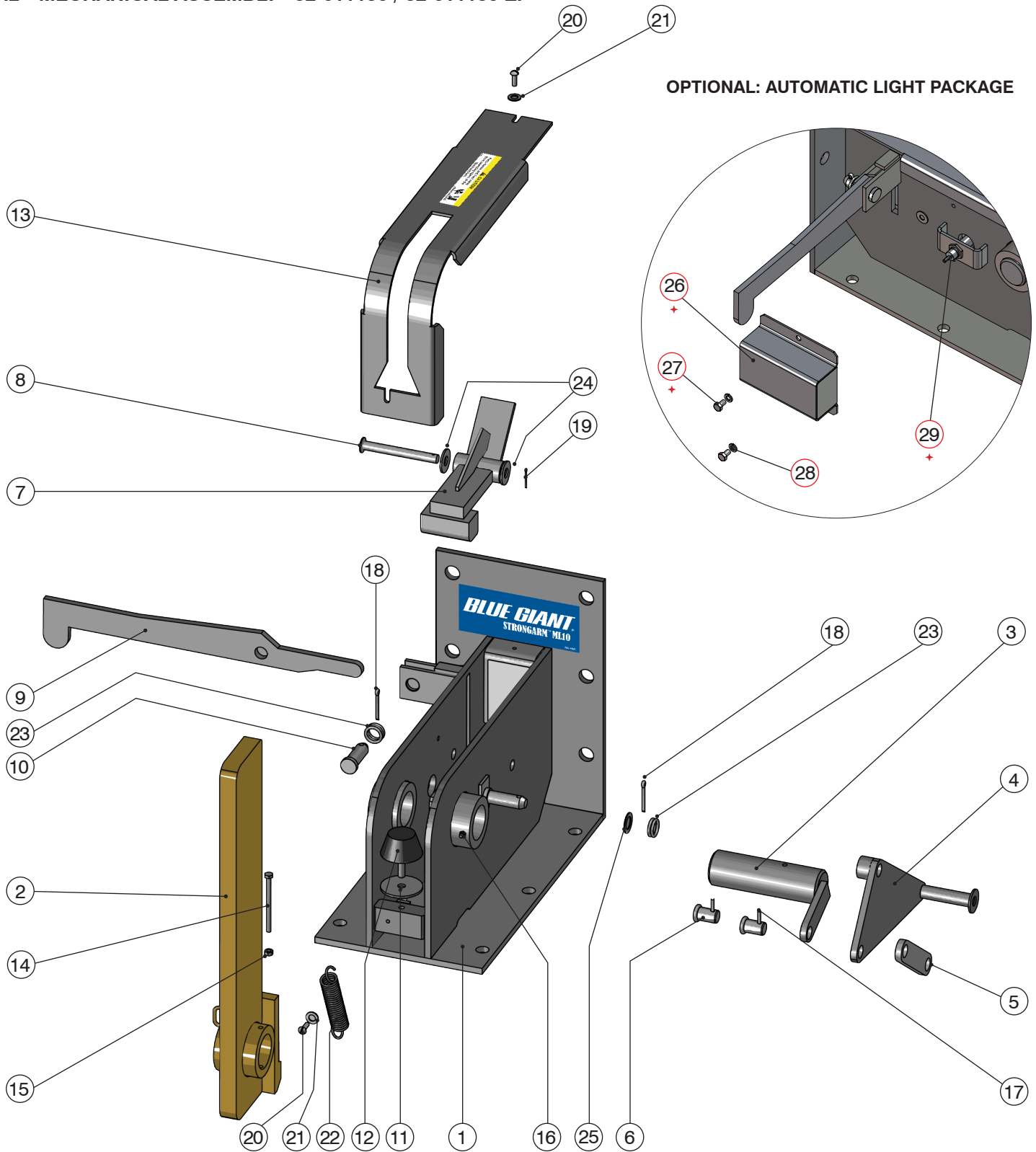

NOTE	PART NO.	DESCRIPTION
★	52-011131	Automatic light package includes parts highlighted

9.2 MECHANICAL ASSEMBLY - 52-011130 / 52-011130-ZP CONT'D.

ITEM	QTY	PART NO.	DESCRIPTION
1	1	52-011160	Body Weldment
		52-011160-ZP	Body Weldment, Zinc Plated
2	1	52-012731	Restraint Arm 26" (660mm)
3	1	522-5005	Shaft Arm Pin
4	1	522-5006	Engagement Arm Weldment
		522-5006-ZP	Engagement Arm Weldment, Zinc Plated
5	1	522-0010	Actuator Linkage
		522-0010-ZP	Actuator Linkage, Zinc Plated
6	2	119-278	Pivot Pin
7	1	522-5001	Lock Weldment
		522-5001-ZP	Lock Weldment, Zinc Plated
8	1	210-0005	Lock Roller Pin Assembly
9	1	522-0000	Release Arm
		522-0000-ZP	Release Arm, Zinc Plated
10	1	107-196	Clevis Pin
11	1	107-046	Washer Spacer
12	1	091-041	Rubber Bumper
13	1	52-011187	Truck Latch Cover
		52-011187-ZP	Truck Latch Cover, Zinc Plated

ITEM	QTY	PART NO.	DESCRIPTION
14	1	011-141	Cap Screw 1/4" - 20 x 3 1/2"(89mm) HH
15	1	011-506	Nuts Hex 1/4" - 20 PLTD
16	2	019-500	Nipple Straight Grease 1/4"
17	2	013-066	5/32" dia. Spring Pin 5/32" x 1 1/4" (32mm)
18	2	013-025	Cotter Pin 3/16" x 1 1/2" (38mm)
19	1	013-018	Cotter Pin 3/32" x 1" (25mm)
20	2	011-020	Round Head Slotted Screws (U.S.)
21	2	012-211	Flat Washer Type B Narrow 3/8"
22	1	017-012	Tension Spring
23	5	106-046	Ring, Split
24	3	012-212	Washer, Zinc-Plated 1/2"
25	1	105-879	Flat Washer 3/4" x 1-3/16" x 1/16"

AUTOMATIC LIGHT PACKAGE MECHANICAL ASSEMBLY - 52-011131 (INCLUDES PART # 52-011130/ 52-011130-ZP)

ITEM	QTY	PART NO.	DESCRIPTION	
+	26	1	52-011115	Sensor Cover
			52-011115-ZP	Sensor Cover, Zinc Plated
+	27	2	010-036	Cap Screw 5/16-18 x 1/2 HH GR. 5 ZC
+	28	2	012-200	Spring Lock Washers 5/16"
+	29	1	028-212	Proximity Sensor 18mm w/ 5m cable + 2 jamb nuts

9.3 GENERAL DIMENSIONS

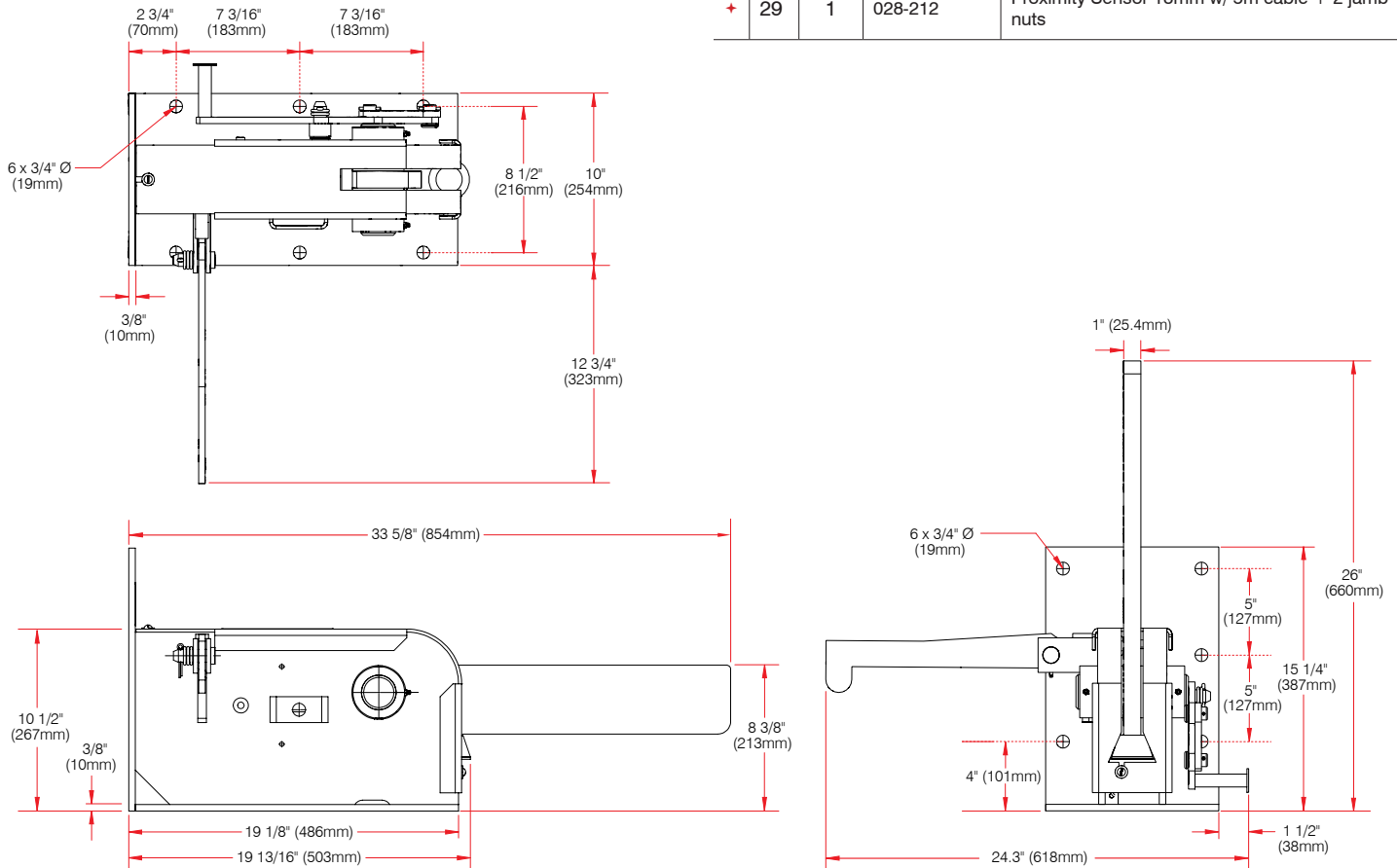

10.0 OPERATING INSTRUCTIONS - STRONGARM™ ML10 WITH TLC24 CONTROLS (AUTOMATIC & MANUAL)

STANDARD OPERATION PROCEDURES

The TLC24-M has interior and exterior LED light signals (red / green) that are manually controlled to communicate safety conditions to both dock workers and truck drivers. The TLC24-A, when operating in automatic mode, detects the position of the interlocked restraint or dock lip via a sensor, allowing the lights to automatically change according to the relevant safety conditions. It may also be operated in manual mode if necessary.

10.1 PRIOR TO USE: EQUIPMENT IN HOME POSITION

The restraint apparatus is in the home position and the dock leveler lip is parked safely in the lip keepers.

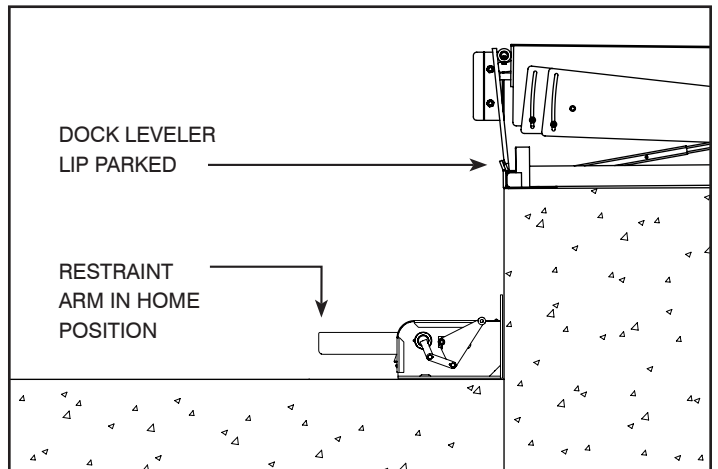
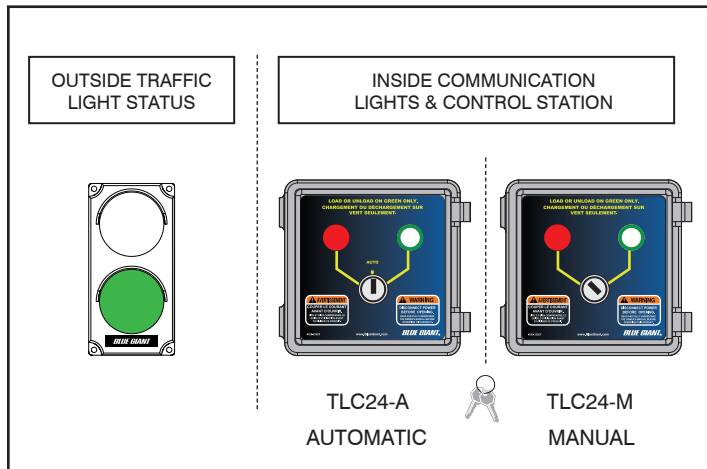

10.2 TRAILER AT BAY

The truck reverses into position against the dock leveler bumpers. The outside traffic light is GREEN and the control station light is RED. Chock the wheels and release the air from the air ride suspension system (if applicable).

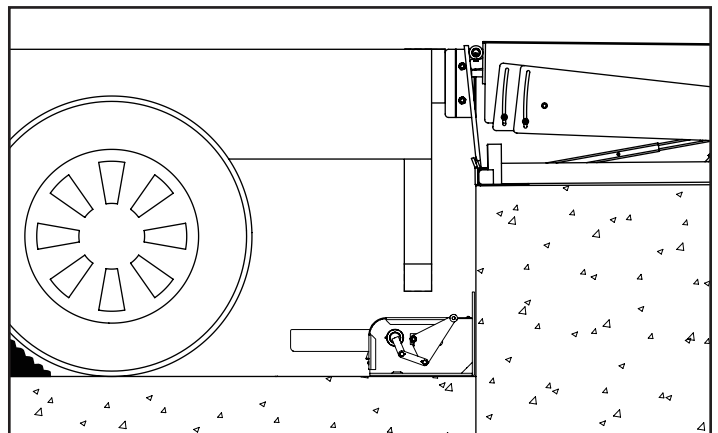
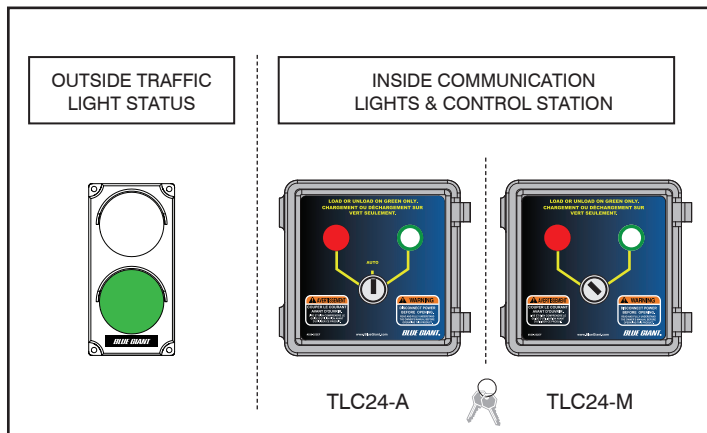

10.3 ENGAGING RESTRAINT

Activate the ML10 by using the control rod to press down on the engagement arm until the restraint arm is in the fully vertical position, holding the ICC bar in place.

TLC24-A: The control station light will turn GREEN and the outside traffic light will turn RED in auto mode.

TLC24-M: Turn the key switch to the 'Interlocked' position (green LED light). The outside traffic light changes to RED while GREEN light on the control station comes on.

NOTE: The truck / trailer is NOT restrained if the arm is not fully vertical. Do not switch the TLC24-M to green until you have confirmed the restraint arm is fully deployed and locked in.

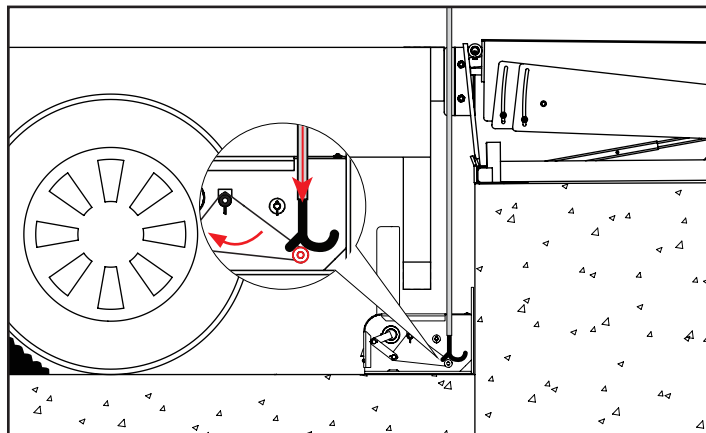
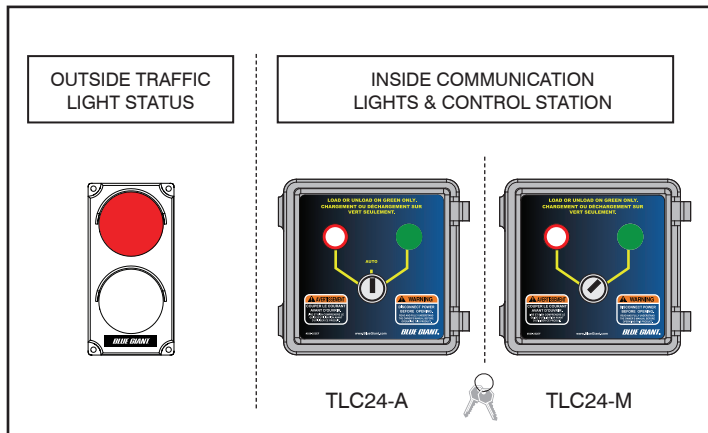

PERFORM LOADING AND UNLOADING

10.4 RELEASING THE RESTRAINT ARM

After loading / unloading has been completed and the dock leveler is safely parked, release the restraint arm by pulling up on it quickly and firmly using the control rod. The arm will return to the parked position.

TLC24-A: The control station light will turn RED and the outside traffic light will turn GREEN in auto mode.

TLC24-M: turn the key switch to the 'No Traffic' (red LED light) position. The outside traffic light changes to GREEN and the control station light turns RED.

NOTE: If the ICC bar is applying pressure to the restraint arm, it may be necessary to have the driver back up the vehicle before releasing the arm.

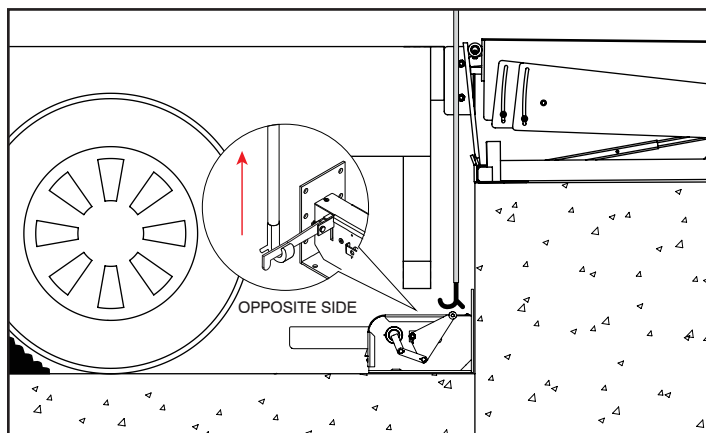
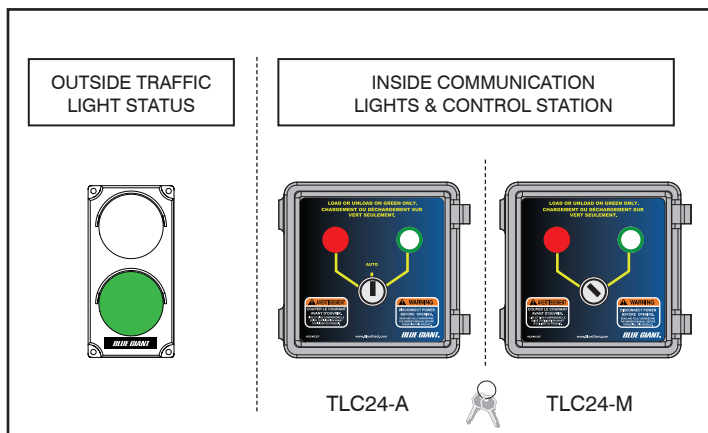

OVERRIDE FEATURES

10.5 MANUAL OVERRIDE MODE (TLC24-A)

Situations may arise that require the TLC24-A to be operated manually. For example:

- The truck ICC bar is bent, damaged, or missing
- The interlock sensor is broken or otherwise inoperable

Under these circumstances, a supervisor or designated authority may operate the TLC24-A in manual override mode by using the key switch to operate the lights manually.

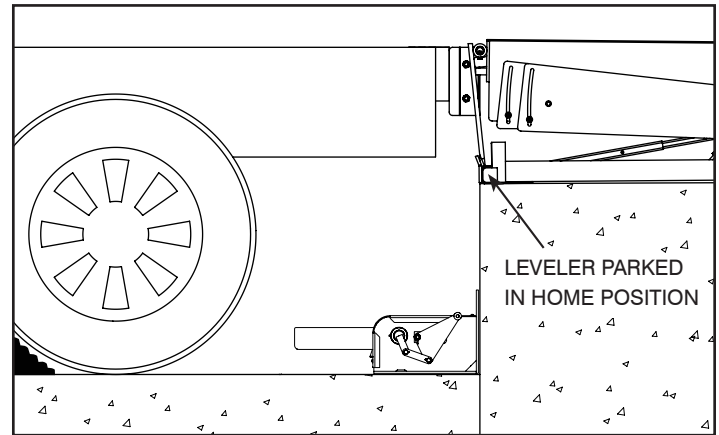
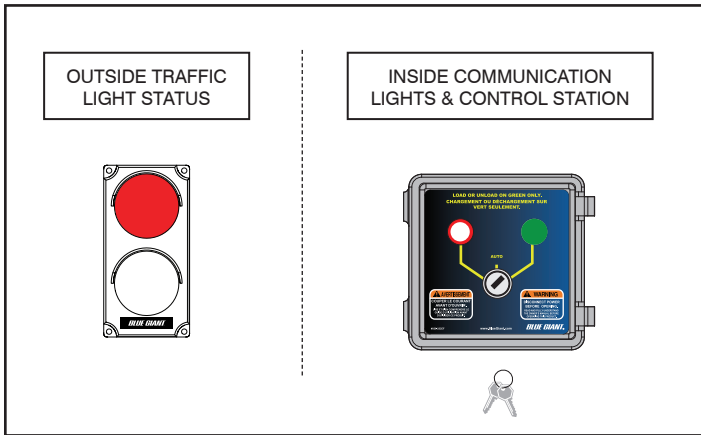

REASON AND OPERATION OF KEYS

- Supervisor usage
- Auto mode is standard
- Keys required to switch selector to any other mode / position

10.6 TLC24 CONTROLS

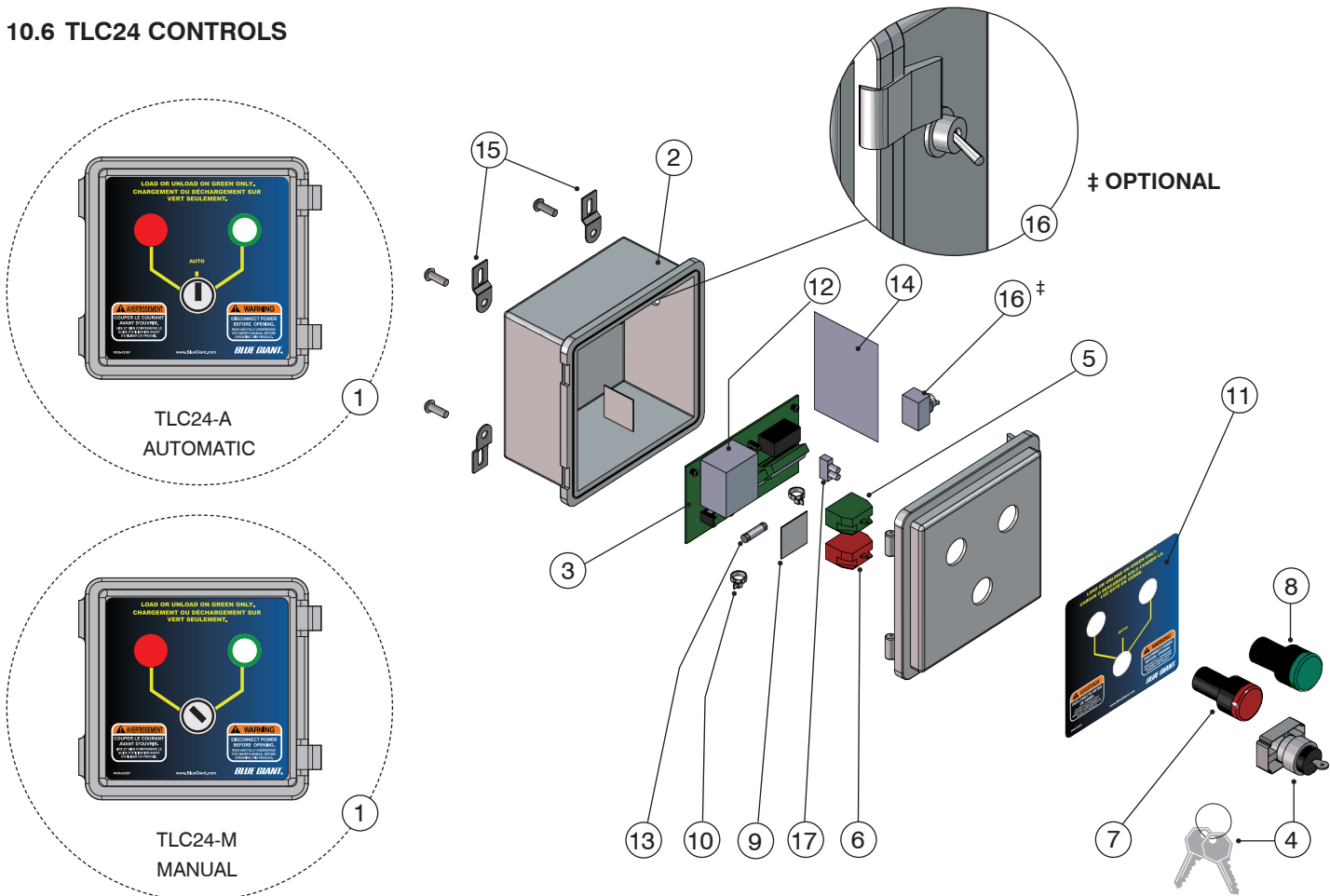

COMPLETE CONTROL STATION ASSEMBLY ITEM # 1					
(Example: TLC24A1115F)					
ITEM	QTY	PART NO.	DESCRIPTION	ASSY PART #	
2	1	025-G023-M	Box, NEMA		
3	1	026-G014-1115	Traffic Lights Controller Board	TLC-24__1115	F
		026-G014-1230		TLC-24__1230	S
4	1	026-G201	3 Position Key Selector Switch	A*	
		026-G207	2 Position Key Selector Switch	M*	
5	1	026-G202	No Contact Block		
6	1	026-G203	No Contact Block		
7	1	026-G205	24V Monoblock LED Indicator – Red		
8	1	026-G206	24V Monoblock LED Indicator – Green		
9	2	025-062	Cable Tie Mount		
10	2	522-008	Tie Wire YS-98C		

COMPLETE CONTROL STATION ASSEMBLY ITEM # 1			
(Example: TLC24A1115F)			
ITEM	QTY	PART NO.	DESCRIPTION
11	1	038-252EF	Decal, Automatic Light System
		038-252ES	
		038-253EF	Decal, Manual Light System
		038-253ES	
12	3	010-216	Screw, M4 x 8 PAN PHIL
13	1	026-G121	Fuse F.A. 100mA, 250V 5 x 20mm
14	1	WD-169	TLC24A Field Wiring Diagram
		WD-168	TLC24M Field Wiring Diagram
15	1	025-G010-1	Mounting Tabs With Hardware (1 pkg of 4)
16	1	026-G209	On/Off Switch ‡ Optional
17	1	025-172-1	Terminal Blocks, 0.32in x11

*A = Automatic *M = Manual

11.0 OPERATING INSTRUCTIONS - STRONGARM™ ML10 WITH BLUE GENIUS™ CONTROLS

11.1 TRAILER AT BAY

The truck reverses into position against the dock leveler bumpers. The outside traffic light is GREEN and the control panel light is RED. Chock the wheels and release the air from the air ride suspension system (if applicable).

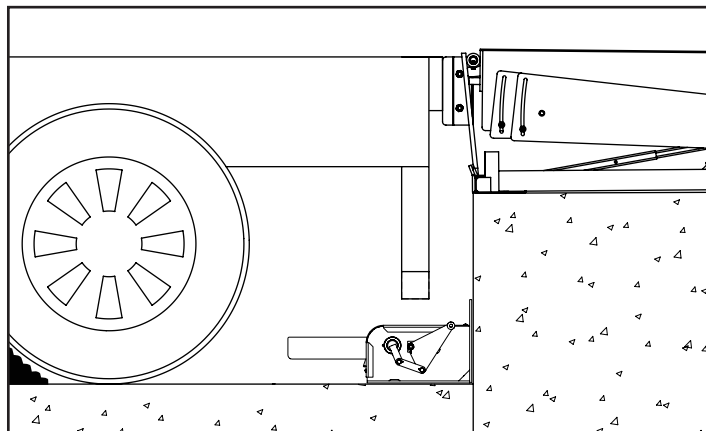
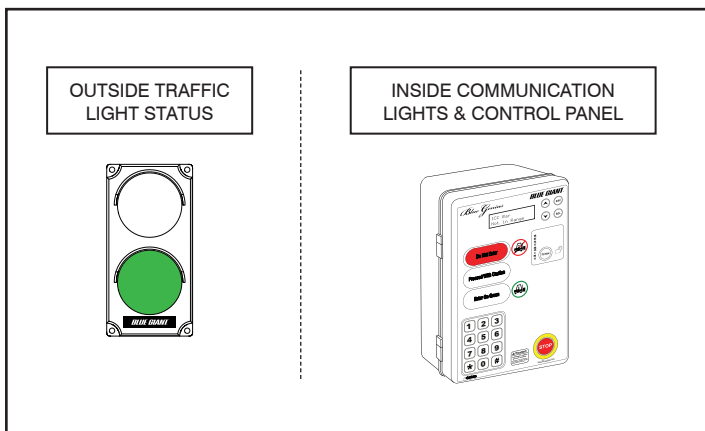

11.2 ENGAGING RESTRAINT

Activate the ML10 by using the control rod to press down on the engagement arm until the restraint arm is in the fully vertical position, holding the ICC bar in place. The outside traffic light changes to RED and the control panel light remains RED. Once the restraint secures the ICC bar, the message on the LCD screen will change to 'Restraint is Engaged' followed by 'Dock Leveler Restored' and 'Ready to Raise Deck'.

NOTE: The truck / trailer is NOT restrained if the arm is not fully vertical and the communication lights do not change color as described above. Do a visual inspection to confirm that the ICC bar is securely restrained before proceeding with loading / unloading.

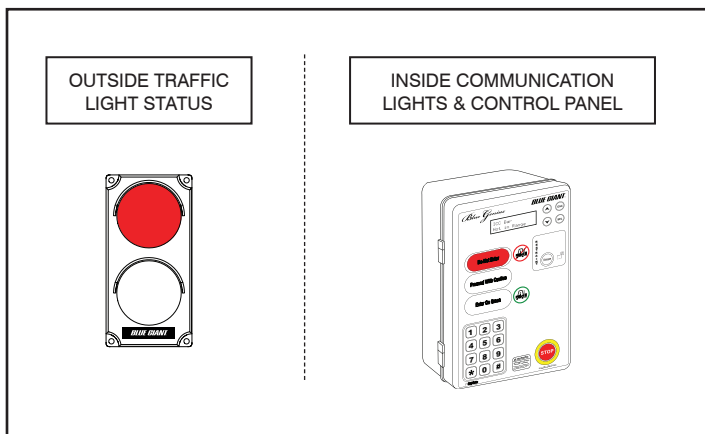
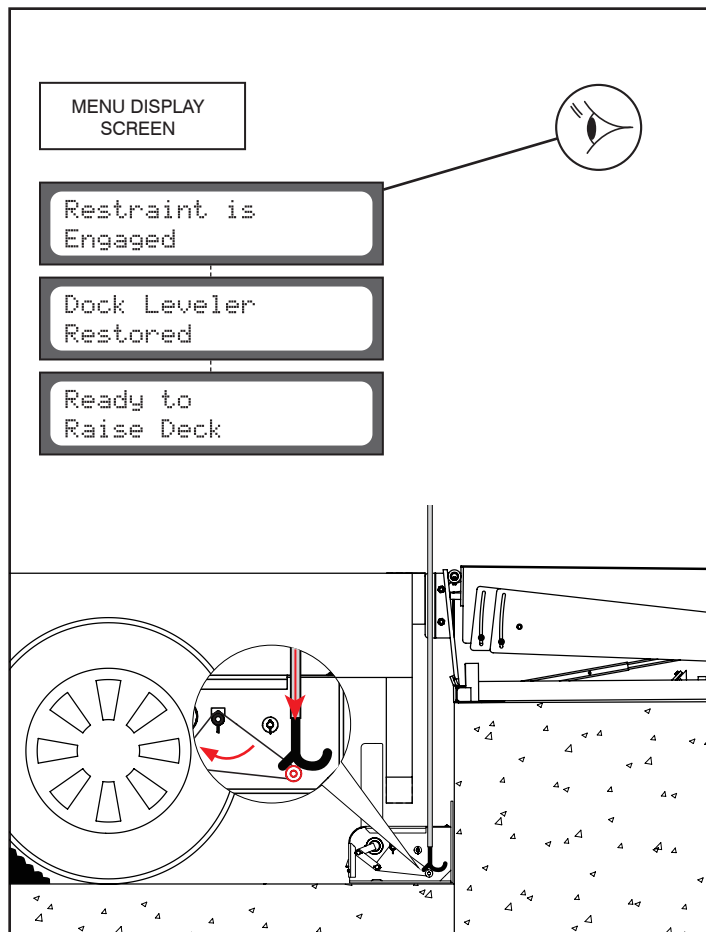

PERFORM LOADING AND UNLOADING

11.3 RELEASING THE RESTRAINT ARM

After loading / unloading has been completed and the dock leveler is safely parked, release the restraint arm by pulling up on it quickly and firmly using the control rod. The arm will return to the parked position. Then touch the 'Release' button. The LCD screen will read 'Restraint Releasing'. When the restraint is in the home position, the message will change to 'Blue Genius Ready' and the control panel light will turn GREEN.

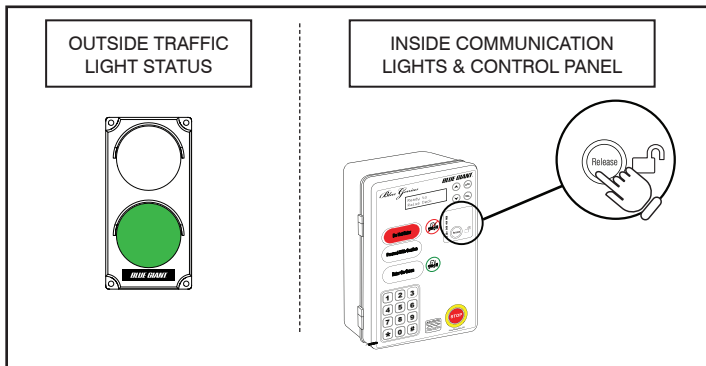

NOTE: If the ICC bar is applying pressure to the restraint arm, it may be necessary to have the driver back up the vehicle before releasing the arm.

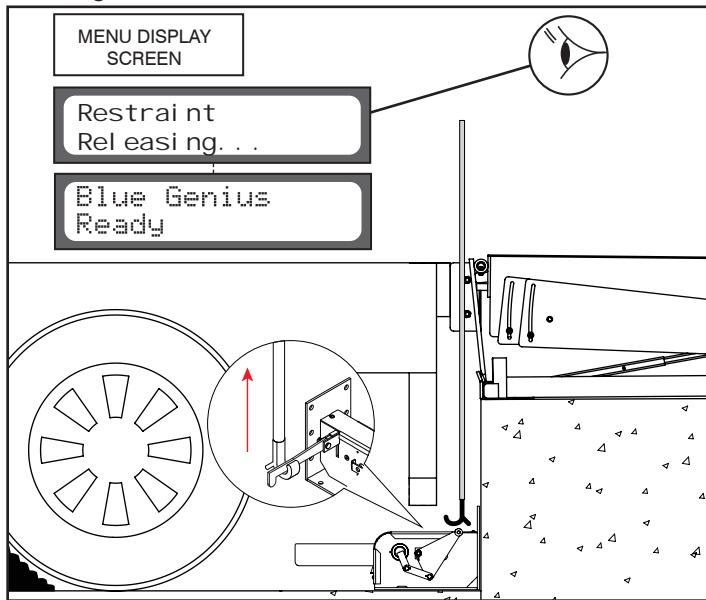

OVERRIDE FEATURES

11.4 MANUAL OVERRIDE MODE

Should it be necessary to bypass the vehicle restraint function (i.e. the truck has an outdated, damaged, or missing ICC bar), a system-approved override code may be entered via the Blue Genius™ touch keypad.

1. Visually verify that restraint cannot engage ICC bar.
2. Press the * key on the keypad.
3. Enter Code. The LCD screen will read **'Dock Leveler Restored'** and then **'Ready to Deploy Deck,'** followed by **'Restraint is Bypassed.'** Once the deck is deployed and the home/lip sensor becomes inactive, the control panel light will turn GREEN while flashing YELLOW. This indicates that the vehicle restraint is not engaged.
4. Ensure that the vehicle is manually chocked before loading and unloading begins.

NOTICE

Please see Section 13.3 for instructions on how to release the restraint arm.

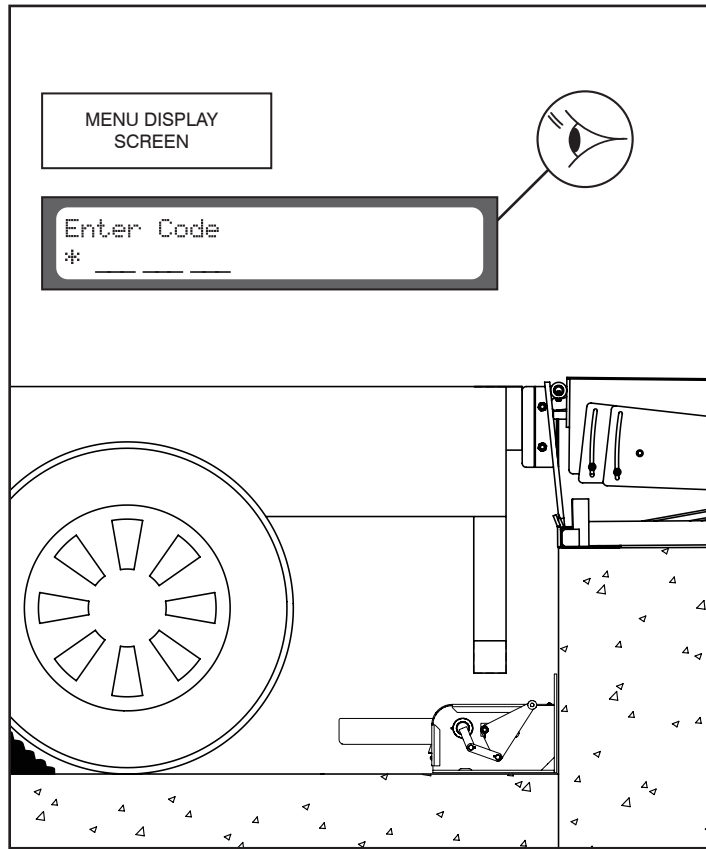
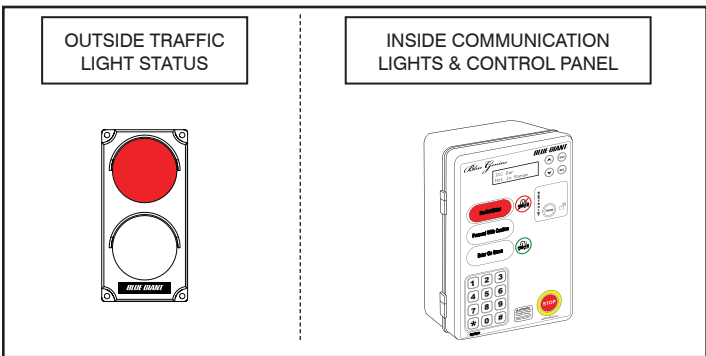

11.5 BLUE GENIUS™ CONTROLS

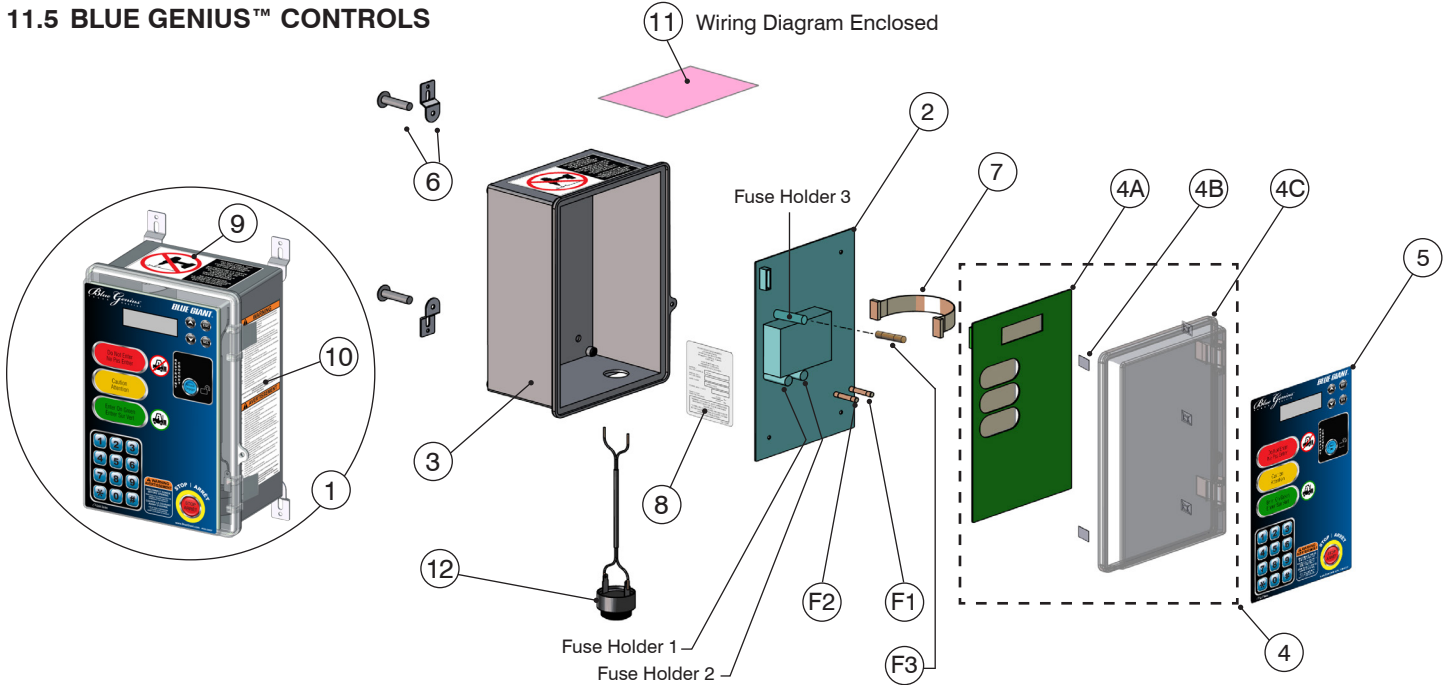

COMPLETE CONTROL STATION ASSEMBLY - ITEM 1 (Example BGG0M1115F)

ITEM	SINGLE PHASE							
	◇	FUSE	QTY	PART NO.	DESCRIPTION	ASSY PART #	*	
2		F1	A	1	Power Board Sub-Assembly † (1PH 115V 50-60HZ)	BGG0M1115	F	
		F2	E	1			S	
		F1	C	1	Power Board Sub-Assembly † (1PH 230V 50-60HZ)	BGG0M1230	F	
		F2		1			S	
	THREE PHASE							
		◇	FUSE	QTY	PART NO.	DESCRIPTION	ASSY PART #	*
2		F1	C	1	Power Board Sub-Assembly † (3PH 230V 50-60HZ)	BGG0M3230	F	
		F2		1			S	
		F1	F	1	Power Board Sub-Assembly † (3PH 400V 50-60HZ)	BGG0M3400	F	
		F2		1			S	
		F1	G	1	Power Board Sub-Assembly † (3PH 460V 50-60HZ)	BGG0M3460	F	
		F2		1			S	
	F1	H	1	Power Board Sub-Assembly † (3PH 575V 60HZ)	BGG0M3575	F		
	F2		1			S		
3			1	025-G010-M	Control Box Enclosure (Includes 4C)			
4			1	025-G014-V3-M	Transparent Cover Door (4C) and Touch Control Board (4A) (Serial # Required)			
4A			1	026-G021-M	Touch Control Board (Serial # Required)			
4B			5	025-062	Cable Tie Mount			
4C			1	025-G014	Transparent Cover Door			
5			1	038-245E	Face Decal	F		
						S		

* Language on decal: F = English / French S = English / Spanish

◇ Location on Power Board † Includes Fuses ‡ 115 Volt Control Box Shown

ITEM	QTY	PART NO.	DESCRIPTION
6	1	025-G010-1	Mounting Tabs with Hardware (1 pkg of 4)
7	1	026-G030	Ribbon Cable
8	1	038-284E	Decal, Serial Plate
		F S	
9	1	038-283EFS	Decal, Do Not Drill
10	1	038-853E	Warning Decal
		F S	
11	1	026-615-1	Anti-Static Poly Bag (Wiring Diagram Enclosed) (Serial # required for diagram)
12	1	026-G402-B	Audible Speaker
F3	1	026-037-1	Fuse, 2.5A, 700V, Fast-Blow 1/4" Glass

AS PER VOLTAGE - SEE ITEM 1

ITEM	QTY	PART NO.	DESCRIPTION
A	1	026-G100	Fuse, 15A, 250V, Time Delay for 1PH, 110-130V
B	1	026-G101	Fuse, 8A, 250V, Time Delay for 1PH, 208-240V
C	1	026-G102	Fuse, 0.5A, 250V, Time Delay for 1 and 3PH, 208-240V
D	1	026-G103	Fuse, 0.25A, 250V, Time Delay for 1PH, 208-240V
E	1	026-G104	Fuse, 0.75A, 250V, Time Delay for 1PH, 110-130V
F	1	026-G105	Fuse, 500mA, 700V, Fast Acting for 3PH, 380-415V
G	1	026-G106	Fuse, 400mA, 700V, Fast Acting for 3PH, 440-480V
H	1	026-G107	Fuse, 315mA, 700V, Fast Acting for 3PH, 575-600V

12.0 EXTERIOR TRAFFIC LIGHT / MIRROR IMAGE SIGN

Slim-build LED traffic lights and mirror image driver warning sign improve loading dock safety.

The LED traffic lights and mirror image drive warning sign improve loading dock safety.

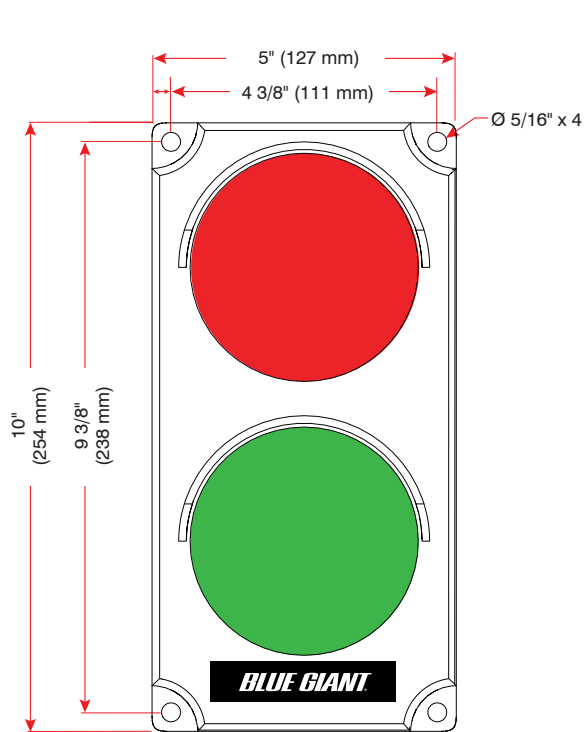

Exterior driver traffic light, part # 032-806.

NOTE: Mount to a flat surface. DO NOT deform light housing with irregular wall surface.

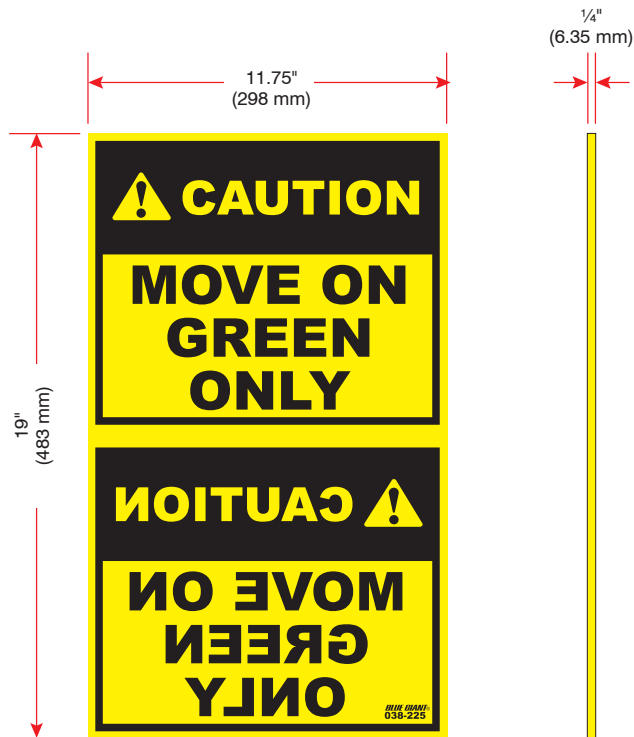

Exterior driver warning sign, part # 038-225.
(French 038-225F / Spanish 038-225S / Portuguese 038-225P)

NOTICE
Use 038-225 instead of 038-806 if using Advanced Light Package.

13.0 VEHICLE RESTRAINT TROUBLESHOOTING

 **WARNING**

Do not attempt to install, make repairs or adjustments. Only a trained and authorized service technician should perform the installation process. Contact your local dealer or distributor for assistance.

PROBLEM	PROBLEM CAUSE
Restraint arm will not rise when the operator pushes down on the actuating arm.	<ol style="list-style-type: none"> 1. Damaged actuating arm or linkage. 2. Foreign material preventing movement of engagement arm. 3. Lack of lubrication at pivot points. 4. Insufficient force applied to the engagement arm.
Restraint arm is not reaching the fully vertical position.	<ol style="list-style-type: none"> 1. Damaged engagement arm or linkage. 2. Foreign material preventing movement of engagement arm. 3. Lack of lubrication at pivot points. 4. Insufficient force applied to the engagement arm. The truck is not parked firmly and squarely against dock bumpers, causing the restraint arm to contact the ICC bar prematurely.
Restraint arm rises to fully vertical position, but does not lock.	<ol style="list-style-type: none"> 1. The engagement arm is not lowering into its locked position. Foreign material inside enclosure may be preventing normal movement of the lock. 2. Release arm struck up, preventing lock from engaging.
The restraint arm will not lower when the operator raises the release arm.	<ol style="list-style-type: none"> 1. The trailer is applying pressure against the restraint arm and lock. Reverse the vehicle firmly against the dock bumpers, and then operate the release arm quickly and sharply 2. Foreign material may be lodged inside the enclosure, preventing the lock from releasing 3. Damaged or broken actuating linkage may be preventing the restraint arm from lowering 4. Damaged or broken spring. 5. Lack of lubrication.
Optional communication lights do not turn on.	<ol style="list-style-type: none"> 1. Power supply to the control station enclosure is turned off. 2. Faulty wiring or connections. 3. Fuse blown in the control station. 4. Faulty selector switch.
One light (either inside or outside) does not operate (Manual or Automatic mode).	<ol style="list-style-type: none"> 1. Faulty wiring or connections. 2. Faulty LED. 3. Faulty selector switch.
Optional communication lights do not change color when the selector switch is moved (Manual system only).	<ol style="list-style-type: none"> 1. Faulty wiring or connections. 2. Faulty selector switch.

13.0 VEHICLE RESTRAINT TROUBLESHOOTING CONT'D.

 WARNING
<p>Do not attempt to install, make repairs or adjustments. Only a trained and authorized service technician should perform the installation process. Contact your local dealer or distributor for assistance.</p>

PROBLEM	PROBLEM CAUSE
Optional communication lights do not change color when the selector switch is moved (Auto system only).	<ol style="list-style-type: none"> 1. Faulty wiring or connections. 2. Faulty selector switch. 3. Proximity switch already active.
Optional communication lights do not change color when the restraining arm is raised to the interlocked position. Lights remain red inside and green outside (Auto system only).	<ol style="list-style-type: none"> 1. Faulty wiring or loose connections. 2. Faulty proximity switch. 3. Sensor is out of adjustment. 4. Selector switch is not set to auto.
Optional communication lights do not change color when the restraint arm is lowered. Lights remain green inside and red outside.	<ol style="list-style-type: none"> 1. Faulty wiring. 2. Faulty or damaged sensor.
Optional communication lights system is displaying wrong signal both indoors and outside (Automatic system only).	<ol style="list-style-type: none"> 1. Wrong type of proximity switch used. 2. Improper installation of sensor.

14.0 WIRING DIAGRAMS

NOTICE
<p>The following wiring diagrams are sample configurations only. Wiring diagrams specific to your needs will be provided inside the control panel and/or as part of your submittal package.</p>

14.1 WIRING DIAGRAM—TLC24-A 115V AND 230V SINGLE PHASE (AUTOMATIC)

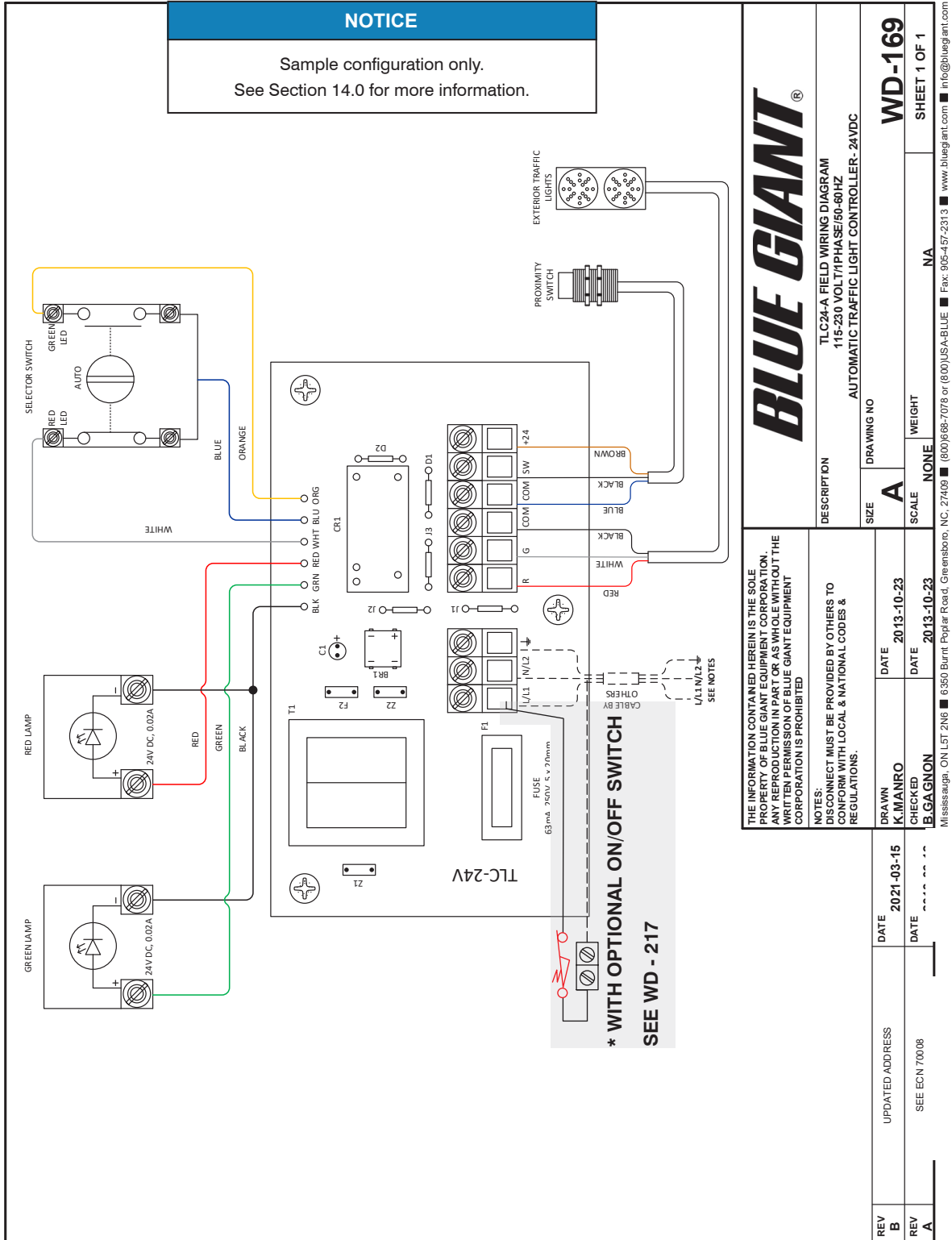

14.2 WIRING DIAGRAM—TLC24-M 115V AND 230V SINGLE PHASE (MANUAL)

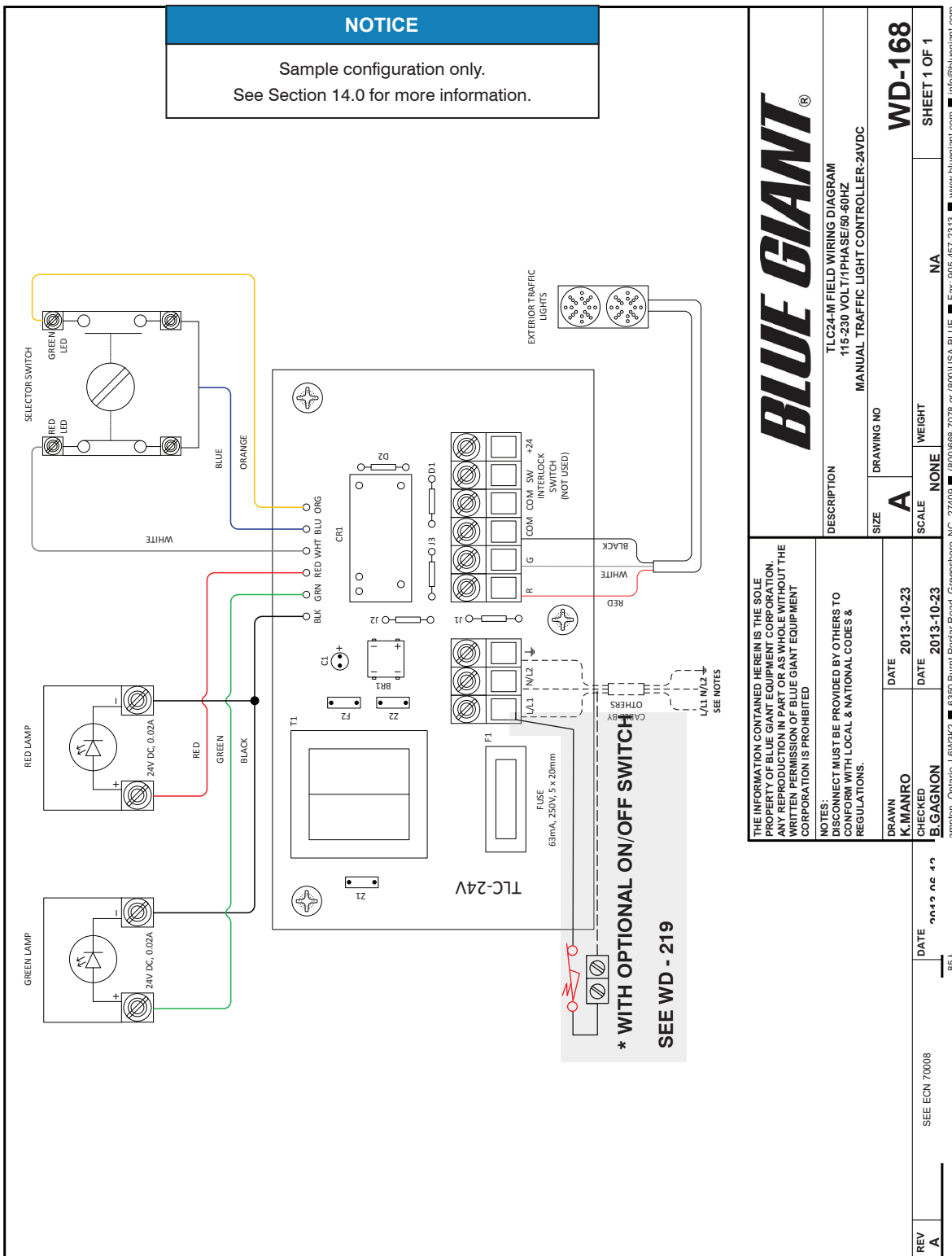

14.3 WIRING DIAGRAM—BLUE GENIUS™ 115V SINGLE PHASE

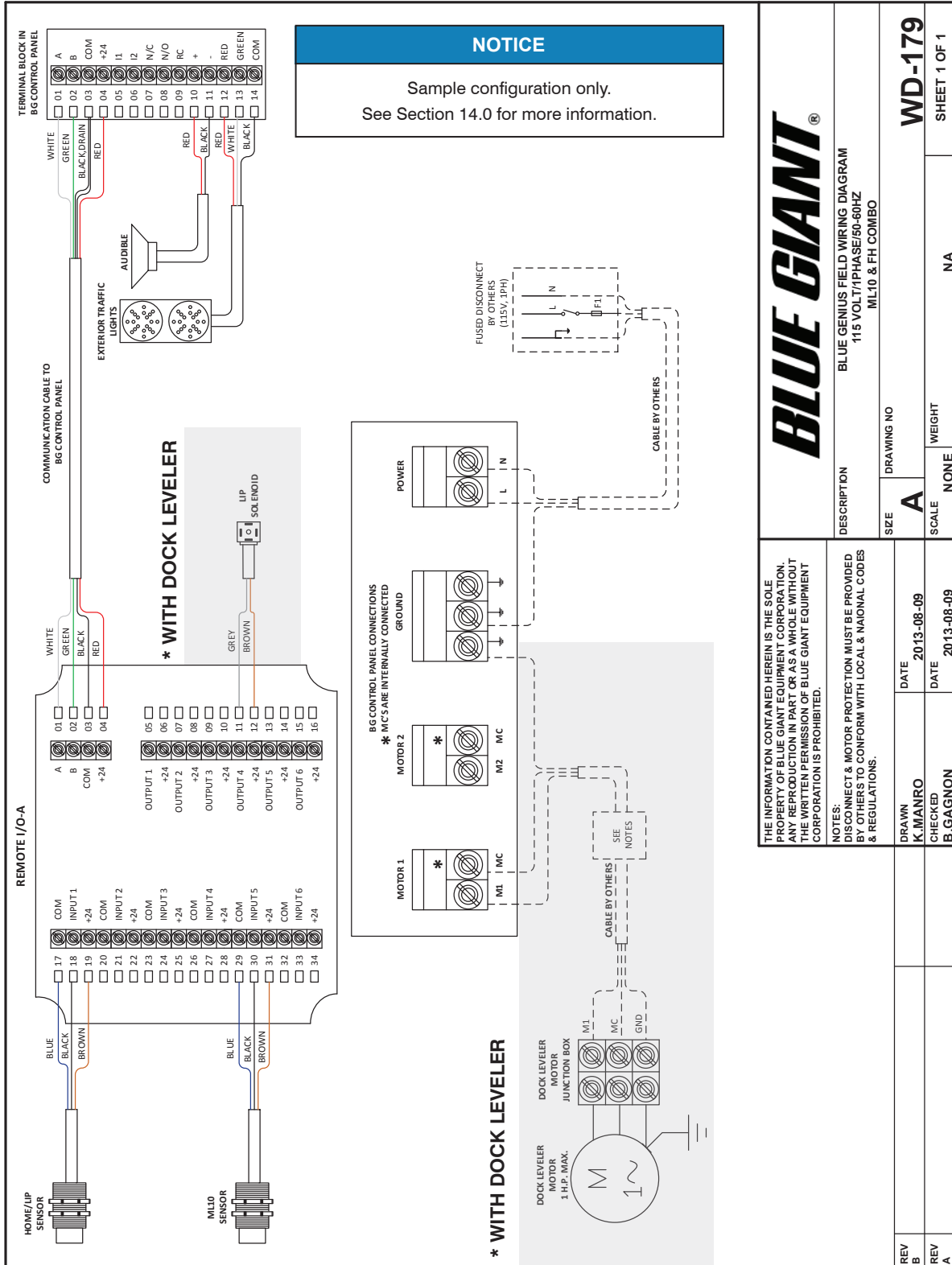

NOTES

BLUE GIANT[®]
BLUE GIANT EQUIPMENT CORPORATION

Corporate 410 Admiral Blvd.
Mississauga, ON, Canada L5T 2N6
t 905.457.3900 f 905.457.2313

USA 6350 Burnt Poplar Road
Greensboro, NC 27409
www.BlueGiant.com