

OWNER'S MANUAL

EPJ-60R RIDER PALLET LIFT TRUCK



WARNING

Do not operate or service this product unless you have read and fully understand the entire contents of this manual. Failure to do so may result in property damage, bodily injury or death.

BLUE GIANT®

WARNING

Do not operate this truck unless you have been authorized and trained to do so, and have read all warnings and instructions in Operator's Manual and on this truck.

Do not operate this truck until you have checked its condition. Give special attention to tires, horn, battery, controller, lift system, brakes, steering mechanism, guards and safety devices.

Operate truck only from designated operating position. Do not carry passengers. Keep feet clear of truck and wear foot protection.

Observe applicable traffic regulations. Yield right of way to pedestrians. Slow down and sound horn at cross aisles and wherever vision is obstructed.

Start, stop, travel, steer and brake smoothly. Slow down for turns and on uneven or slippery surfaces that could cause truck to slide or overturn. Use special care when traveling without load as the risk of overturn may be greater.

Always look in direction of travel. Keep a clear view, and when load interferes with visibility, travel with load trailing.

Use special care when operating on ramps travel slowly, and do not angle or turn. Travel with load downhill.

Do not handle loads which are higher than the load backrest or load backrest extension unless load is secured so that no part of it could fall backward. Before lifting, be sure load is centered, forks are completely under load, and load is as far back as possible against load backrest.

When leaving truck, neutralize travel control, fully lower lifting mechanism and set brake. When leaving truck unattended, also shut off power.

TABLE OF CONTENTS

| Section | Page | Section | Page |
|---------------------------------------------|------|----------------------------------------------|------|
| 1 DESCRIPTION | 1-1 | 6 BRAKE SERVICING | 6-1 |
| 1-1. INTRODUCTION..... | 1-1 | 6-1. BRAKE..... | 6-1 |
| 1-2. GENERAL DESCRIPTION..... | 1-1 | 6-1.1. AIR GAP ADJUSTMENT..... | 6-1 |
| 1-3. SAFETY FEATURES..... | 1-2 | 6-1.2. STOPPING DISTANCE ADJUSTMENT..... | 6-2 |
| 2 OPERATION | 2-1 | 6-1.3. BRAKE ASSEMBLY REPLACEMENT | 6-2 |
| 2-1. GENERAL..... | 2-1 | 7 TRANSMISSION, DRIVE WHEEL, LOAD WHEEL | 7-1 |
| 2-2. OPERATING PRECAUTIONS..... | 2-1 | 7-1. DRIVE WHEEL..... | 7-1 |
| 2-3. BEFORE OPERATION..... | 2-1 | 7-2. TRANSMISSION..... | 7-1 |
| 2-4. TRAVEL..... | 2-4 | 7-3. LOAD WHEEL..... | 7-3 |
| 2-4.1. BRAKE..... | 2-4 | 7-3.1. REMOVAL..... | 7-3 |
| 2-4.2. TRAVEL..... | 2-4 | 7-3.2. REPAIR..... | 7-3 |
| 2-4.3. BELLY-BUTTON SWITCH..... | 2-4 | 7-3.3. LOAD WHEEL INSTALLATION..... | 7-3 |
| 2-5. STEERING ARM GAS SPRING..... | 2-5 | 7-4. CASTERS..... | 7-3 |
| 2-6. LIFT AND LOWER CONTROLS..... | 2-5 | 8 ELEVATION SYSTEM SERVICING | 8-1 |
| 2-7. LOADING AND UNLOADING..... | 2-5 | 8-1. LIFT LINKAGE..... | 8-1 |
| 2-8. PARKING..... | 2-5 | 8-1.1. REMOVAL..... | 8-1 |
| 3 PLANNED MAINTENANCE | 3-1 | 8-1.2. REPAIR..... | 8-1 |
| 3-1. GENERAL..... | 3-1 | 8-1.3. INSTALLATION..... | 8-1 |
| 3-2. MONTHLY AND QUARTERLY CHECKS..... | 3-1 | 9 HYDRAULIC SYSTEM SERVICING..... | 9-1 |
| 3-3. BATTERY CARE..... | 3-1 | 9-1. LINES AND FITTINGS..... | 9-1 |
| 3-3.1. GENERAL..... | 3-1 | 9-2. HYDRAULIC PUMP, MOTOR, AND | |
| 3-3.2. SAFETY RULES..... | 3-2 | RESERVOIR ASSY..... | 9-1 |
| 3-3.3. BATTERY CARE AND CHARGING..... | 3-2 | 9-2.1. REMOVAL..... | 9-1 |
| 3-3.4. BATTERY CLEANING..... | 3-2 | 9-2.2. DISASSEMBLY AND REASSEMBLY..... | 9-3 |
| 3-3.5. MAINTENANCE FREE BATTERIES..... | 3-3 | 9-2.3. INSTALLATION..... | 9-3 |
| 3-4. CHARGING BATTERIES..... | 3-3 | 9-2.4. LIFT CYLINDER..... | 9-3 |
| 3-5. LUBRICATION..... | 3-4 | 10 ELECTRICAL COMPONENTS..... | 10-1 |
| 4 TROUBLESHOOTING | 4-1 | 10-1. ELECTRICAL CONTROL PANEL..... | 10-1 |
| 4-1. GENERAL..... | 4-1 | 10-1.1. MAINTENANCE..... | 10-1 |
| 4-2. CONTROLLER TROUBLESHOOTING..... | 4-4 | 10-1.2. CLEANING..... | 10-1 |
| 4-2.1. ZAPI CAN CONSOLE KIT..... | 4-4 | 10-1.3. PANEL REMOVAL..... | 10-1 |
| 4-2.2. DIAGNOSTIC HISTORY..... | 4-6 | 10-1.4. PANEL DISASSEMBLY..... | 10-1 |
| 4-2.3. ADJUSTMENT..... | 4-6 | 10-1.5. PANEL INSTALLATION..... | 10-1 |
| 5 STEERING ARM, CONTROL HEAD AND | | 10-2. HORN REPLACEMENT..... | 10-4 |
| COMPARTMENT | 5-1 | 10-3. PUMP MOTOR..... | 10-5 |
| 5-1. CONTROL HEAD..... | 5-1 | 10-4. DRIVE MOTOR..... | 10-5 |
| 5-1.1. COVER REMOVAL..... | 5-1 | 10-4.1. MOTOR REMOVAL..... | 10-5 |
| 5-1.2. COVER INSTALLATION..... | 5-2 | 10-4.2. MOTOR INSTALLATION..... | 10-5 |
| 5-1.3. CONTROL HEAD REMOVAL..... | 5-3 | 10-5. LIFT LIMIT SWITCH..... | 10-5 |
| 5-1.4. CONTROL HEAD INSTALLATION..... | 5-3 | 10-5.1. REPLACEMENT..... | 10-5 |
| 5-1.5. BELLY-BUTTON SWITCH REPLACEMENT..... | 5-3 | 10-5.2. ADJUSTMENT..... | 10-5 |
| 5-1.6. HORN, LIFT AND LOWER SWITCH | | 10-6. DEADMAN SWITCH..... | 10-6 |
| REPLACEMENT..... | 5-3 | 10-6.1. REPLACEMENT..... | 10-6 |
| 5-1.7. SPEED POTENTIOMETER REPLACEMENT..... | 5-3 | 11 OPTIONAL EQUIPMENT | 11-1 |
| 5-2. STEERING ARM..... | 5-3 | 11-1. LOAD BACKREST..... | 11-1 |
| 5-2.1. RETURN SPRING REPLACEMENT..... | 5-3 | 12 ILLUSTRATED PARTS BREAKDOWN..... | 12-1 |
| 5-2.2. STEERING ARM REMOVAL..... | 5-4 | | |
| 5-2.3. STEERING ARM INSTALLATION..... | 5-4 | | |
| 5-3. COMPARTMENT COVERS..... | 5-4 | | |
| 5-3.1. REMOVAL..... | 5-4 | | |
| 5-3.2. INSTALLATION..... | 5-4 | | |

TABLE OF CONTENTS - Continued

LIST OF ILLUSTRATIONS

| Figure | Page | Figure | Page | | |
|--------|-------------------------------------|--------|-------|----------------------------------------------|-------|
| 1-1 | NAME PLATE | 1-1 | 8-2 | LIFT LINKAGE..... | 8-3 |
| 1-2 | EPJ-60R LIFT TRUCK..... | 1-1 | 9-1 | HYDRAULIC SYSTEM..... | 9-2 |
| 2-1 | SAMPLE OF OPERATOR CHECK LIST | 2-3 | 9-2 | PUMP & MOTOR ASSY..... | 9-4 |
| 2-2 | BRAKE ACTUATION | 2-4 | 9-3 | LIFT CYLINDER..... | 9-5 |
| 2-3 | CONTROL HEAD..... | 2-4 | 10-1 | SCREEN 11..... | 10-1 |
| 2-4 | GRAB BAR..... | 2-5 | 10-2 | ELECTRICAL SYSTEM..... | 10-2 |
| 3-1 | LUBRICATION DIAGRAM | 3-5 | 10-3 | ELECTRICAL PANEL..... | 10-3 |
| 4-1 | CONNECTING THE HANDSET | 4-4 | 10-4 | SCREEN 11..... | 10-4 |
| 4-2 | ZAPI PC CAN CONSOLE SCREEN | 4-4 | 10-5 | BRAKE ACTUATION..... | 10-4 |
| 4-3 | DEVICE CONFIGURATION SCREEN..... | 4-4 | 10-6 | TRANSMISSION, MOTOR, BRAKE ASSEMBLY | 10-5 |
| 4-4 | CONFIGURATION CAN SCREEN | 4-4 | 12-1 | STEERING SYSTEM | 12-2 |
| 4-5 | CAN HARDWARE SCREEN..... | 4-5 | 12-2 | STEERING ARM | 12-4 |
| 4-6 | CONFIGURATION CAN SCREEN | 4-5 | 12-3 | CONTROL HEAD | 12-6 |
| 4-7 | ZAPI PC CAN CONSOLE SCREEN | 4-5 | 12-4 | GRAB BAR ASSEMBLY..... | 12-8 |
| 4-8 | SET NODE SCREEN..... | 4-5 | 12-5 | DRIVE SYSTEM..... | 12-10 |
| 4-9 | ZAPI PC CAN CONSOLE SCREEN | 4-5 | 12-6 | TRANSMISSION, MOTOR, BRAKE ASSEMBLY | 12-12 |
| 4-10 | PASSWORD SCREEN | 4-5 | 12-7 | FRAME | 12-14 |
| 4-11 | ZAPI PC CAN CONSOLE SCREEN | 4-6 | 12-8 | LIFT LINKAGE..... | 12-16 |
| 4-12 | ZAPI PC CAN CONSOLE SCREEN | 4-6 | 12-9 | CASTER WHEEL | 12-18 |
| 4-13 | ALARM LOGBOOK SCREEN..... | 4-6 | 12-10 | HYDRAULIC SYSTEM..... | 12-20 |
| 4-14 | ZAPI PC CAN CONSOLE SCREEN | 4-6 | 12-11 | PUMP & MOTOR ASSY..... | 12-22 |
| 4-15 | PARAMETERS SCREEN | 4-7 | 12-12 | LIFT CYLINDER | 12-24 |
| 5-1 | STEERING ARM..... | 5-1 | 12-13 | ELECTRICAL SYSTEM..... | 12-26 |
| 5-2 | CONTROL HEAD..... | 5-2 | 12-14 | ELECTRICAL PANEL..... | 12-28 |
| 5-3 | STEERING SYSTEM..... | 5-5 | 12-15 | WIRING HARNESS..... | 12-30 |
| 6-1 | BRAKE ASSEMBLY..... | 6-1 | 12-16 | WIRING CABLES | 12-32 |
| 7-1 | TRANSMISSION, MOTOR, BRAKE ASSEMBLY | 7-1 | | | |
| 7-2 | DRIVE SYSTEM | 7-2 | | | |
| 8-1 | FRAME..... | 8-2 | | | |

LIST OF TABLES

| Table | Page | Table | Page | | |
|-------|-------------------------------------------------------------|-------|------|-----------------------------|-----|
| 2-1 | OPERATOR CHECKS | 2-2 | 4-1 | TROUBLESHOOTING CHART | 4-1 |
| 3-1 | MONTHLY AND QUARTERLY INSPECTION AND SERVICE CHART | 3-1 | 4-2 | ADJUSTMENT SETTINGS | 4-7 |
| 3-2 | RECOMMENDED LUBRICANTS | 3-4 | 4-3 | FACTORY SETTING..... | 4-7 |
| 3-3 | LUBRICATION CHART..... | 3-5 | | | |

SECTION 1 DESCRIPTION

1-1. INTRODUCTION.

This publication describes the 24 volt transistor EPJ-60R lift truck distributed by Blue Giant. Included are operating instructions, planned maintenance instructions, lubrication procedures, corrective maintenance procedures and a complete parts list with part location illustrations.

Users shall comply with all requirements indicated in applicable OSHA standards and current edition of A.N.S.I. B56.1 Part II. By following these requirements and the recommendations contained in this manual, you will receive many years of dependable service from your EPJ-60R lift truck.

1-2. GENERAL DESCRIPTION.

The self-propelled WPT 60 truck, [Figure 1-2](#), lifts and transports payloads up to 6000 pounds on rigid forks.

The truck can be operated from the walking position using the control head or from the riding position using the grab bar.

The battery powered lift truck is quiet and without exhaust fumes.

The reversible AC motor propels the lift truck in forward or reverse direction throughout the available

speed range. The EPJ-60R lift truck can be driven with forks raised or lowered. The lift truck must be protected from the elements.

The model number will be found on the name plate ([Figure 1-1](#)) along with the serial number, lifting capacity, and load center. [Figure 1-2](#) shows the locations of the truck's main components and controls.

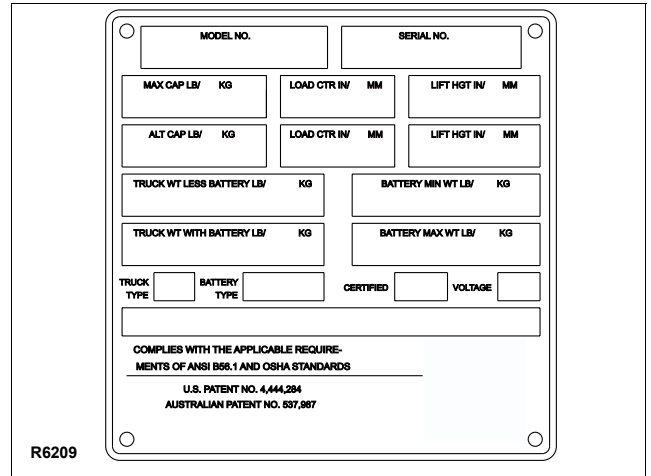

Figure 1-1 Name Plate

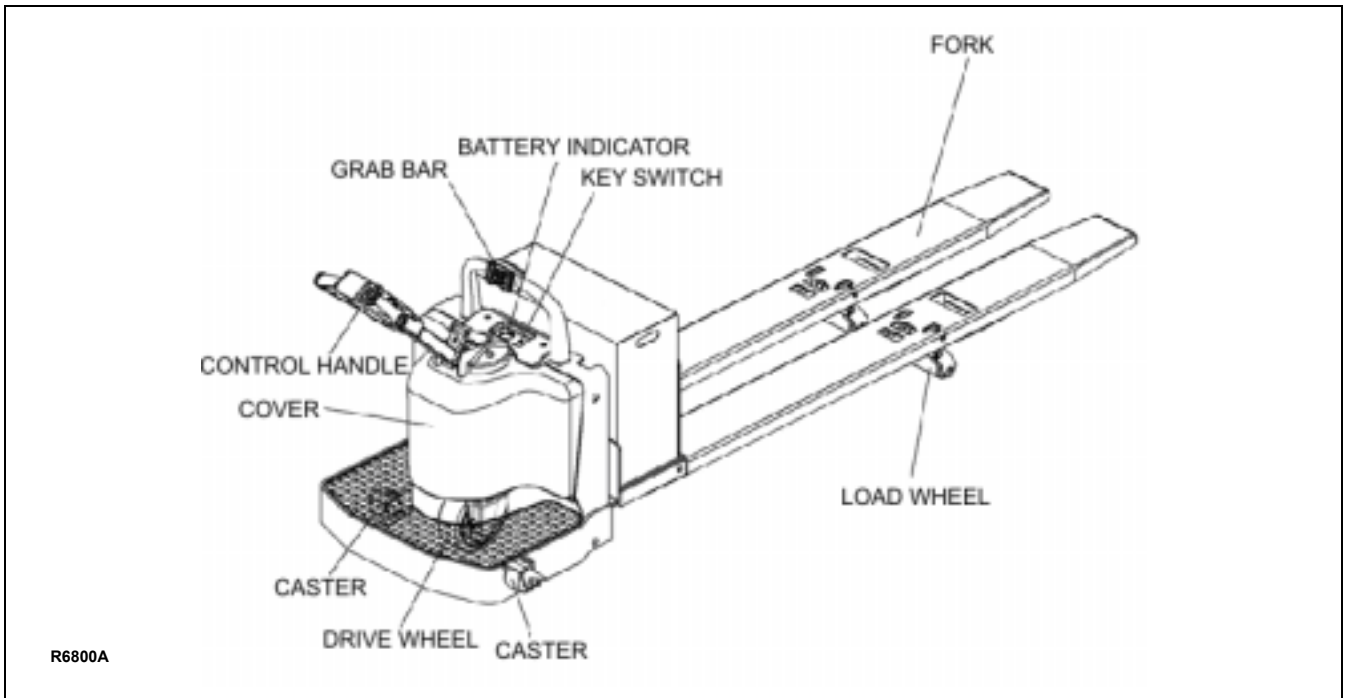

Figure 1-2 EPJ-60R Lift Truck

1-3. SAFETY FEATURES.

The EPJ-60R is designed and engineered to provide maximum safety for operator and payload. Some of the safety features incorporated into the design are:

- Dead-man brake to apply the brake and cut off drive power when the steering arm is released.
- Belly-button switch to reverse truck should the operator accidentally pin himself against a wall or obstruction when backing up in slow speed.
- All control functions automatically return to "OFF" when released.
- Externally accessible quick-disconnect battery plug within operator's reach.
- Separately fused control circuits and power circuits.
- Readily accessible horn button.
- Handle to provide a firm hand hold for operator.
- Flow control valve regulates maximum lowering speed within prescribed limits.
- Relief valve maintains hydraulic pressure within prescribed limits.
- High visibility color scheme of truck provides visual alert of truck's presence.
- Battery Indicator
- Casters

SECTION 2 OPERATION

2-1. GENERAL.

This section gives detailed operating instructions for the EPJ-60R lift truck. The instructions are divided into the various phases of operations, such as operating lift, driving, and stopping. Routine precautions are included for safe operation.

2-2. OPERATING PRECAUTIONS.

WARNING: Improper operation of the lift truck may result in operator injury, or load and/or lift truck damage. Observe the following precautions when operating the EPJ-60R lift truck.

The following safety precautions must be adhered to at all times.

- Do not operate this truck unless you have been trained and authorized to do so and have read all warnings and instructions in this manual and on the truck.
- All warnings and instructions must be read and understood before using the equipment.
- Equipment must be inspected by a qualified person on a regular basis.
- Do not operate this truck until you have checked its condition. Give special attention to Tires, Horn, Batteries, Controller, Lift System, Brakes, Steering Mechanism, Guards and Safety Devices
- Operate truck only from designated operation position. Wear foot protection. Do not carry passengers.
- Observe applicable traffic regulations. Yield right of way to pedestrians. Slow down and sound horn at cross aisles and wherever vision is obstructed.
- Start, stop, travel, steer and brake smoothly. Slow down for turns and on uneven or slippery surfaces that could cause truck to slide or overturn. Use special care when traveling without load as the risk of overturn may be greater.
- Always look in direction of travel. Keep a clear view, and when load interferes with visibility, travel with load or lifting mechanism trailing.

- Do not overload truck. Check nameplate for load weight and load center information.
- Before lifting, be sure load is centered, forks are completely under load, and load is as far back as possible against load backrest.
- Do not handle loads which are higher than the load backrest unless load is secured so that no part of it could fall backward.
- When leaving truck, neutralize travel control. Fully lower lifting mechanism and set brake. When leaving truck unattended, turn off key switch and disconnect switch, remove key and disconnect battery.

2-3. BEFORE OPERATION

Table 2-1 covers important inspection points on the EPJ-60R lift truck which should be checked prior to operation. Depending on use, some trucks may require additional checks.

Figure 2-1 shows a sample format for an Operator Checklist, which can be modified as necessary to fit your operation.

WARNING: Periodic maintenance of this truck by a QUALIFIED TECHNICIAN is required.

CAUTION: A QUALIFIED SERVICE TECHNICIAN should check the truck monthly for proper lubrication, proper fluid levels, brake maintenance, motor maintenance and other areas specified in the **SECTION 3**.

WARNING: If the truck is found to be unsafe and in need of repair, or contributes to an unsafe condition, report it immediately to the designated authority. Do not operate it until it has been restored to a safe operating condition. Do not make any unauthorized repairs or adjustments. All service must be performed by a qualified maintenance technician.

Table 2-1 Operator Checks

| ITEM | PROCEDURE |
|-------------------------------------|--------------------------------------------------------------------------------------------------------------------------------------|
| Transmission and hydraulic systems. | Check for signs of fluid leakage. |
| Forks | Check for cracks and damage. |
| Safety signs | Check that warning labels, nameplate, etc., are in good condition and legible. |
| Horn | Check that horn sounds when operated. |
| Steering | Check for binding or looseness in steering arm when steering. |
| Travel controls | Check that speed controls on control head operate in all speed ranges in forward and reverse and that belly button switch functions. |

| ITEM | PROCEDURE |
|---------------------------|---------------------------------------------------------------------------------------------------------------------|
| Wheels | Check drive wheel for cracks or damage. Move truck to check load for freedom of rotation. |
| Hydraulic controls | Check operation of lift and lower to their maximum positions. |
| Brakes | Check that brakes actuate when steering arm is raised to upright position, and when lowered to horizontal position. |
| Deadman/ Parking brake | Check that steering arm raises to upright position when released and brake applies. |
| Battery disconnect | Check that battery can be disconnected and reconnected. Check for connector damage. |
| Battery charge | Check the battery indicator. |

Electric Truck Daily Operator Check-Off List

Date _____ Operator _____

Truck No. _____ Model No. _____

Dept. _____ Shift _____

Hour Meter
Reading—Drive _____ Hoist _____

| Check | O.K. (✓) | Need Maintenance |
|----------------------------------------------------|----------|------------------|
| Tires | | |
| Load Wheels | | |
| Horn | | |
| Lift—Lower Control | | |
| Attachment Operation | | |
| Forward & Reverse Controls | | |
| Steering | | |
| Brakes | | |
| Hydraulic Leaks, Cylinders, Valves, Hoses, Etc. | | |

Figure 2-1 Sample of Operator Check List

2-4. TRAVEL.

2-4.1. Brake

The brake is fully applied by lowering or raising the steering arm. (See Figure 2-2) All travel control power is shut off when the brake is engaged. When the steering arm is in the upright position, the brake acts as a parking brake. Deadman braking occurs when the handle is released and spring action raises steering arm to the upright position.

2-4.2. Travel

Move the control arm to the travel position. The speed control (See Figure 2-3) located on each side of the control head provides fingertip control for driving the truck. Rotate the control in the direction you want to travel. The farther you rotate the control from the neutral position, the faster the truck will travel.

2-4.3. Belly-Button Switch

The belly-button switch (Figure 2-3) minimizes the possibility of the driver being pinned by the steering arm while driving the lift truck in the walking position. If the switch presses against the operator while the lift

truck is being driven toward the operator, the switch changes the direction of the lift truck.

In an emergency, pull out battery connector, all electrical functions are cut out and the truck automatically brakes.

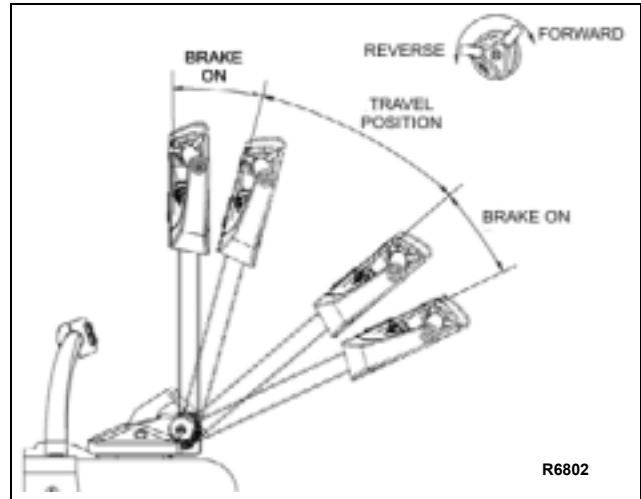

Figure 2-2 Brake Actuation

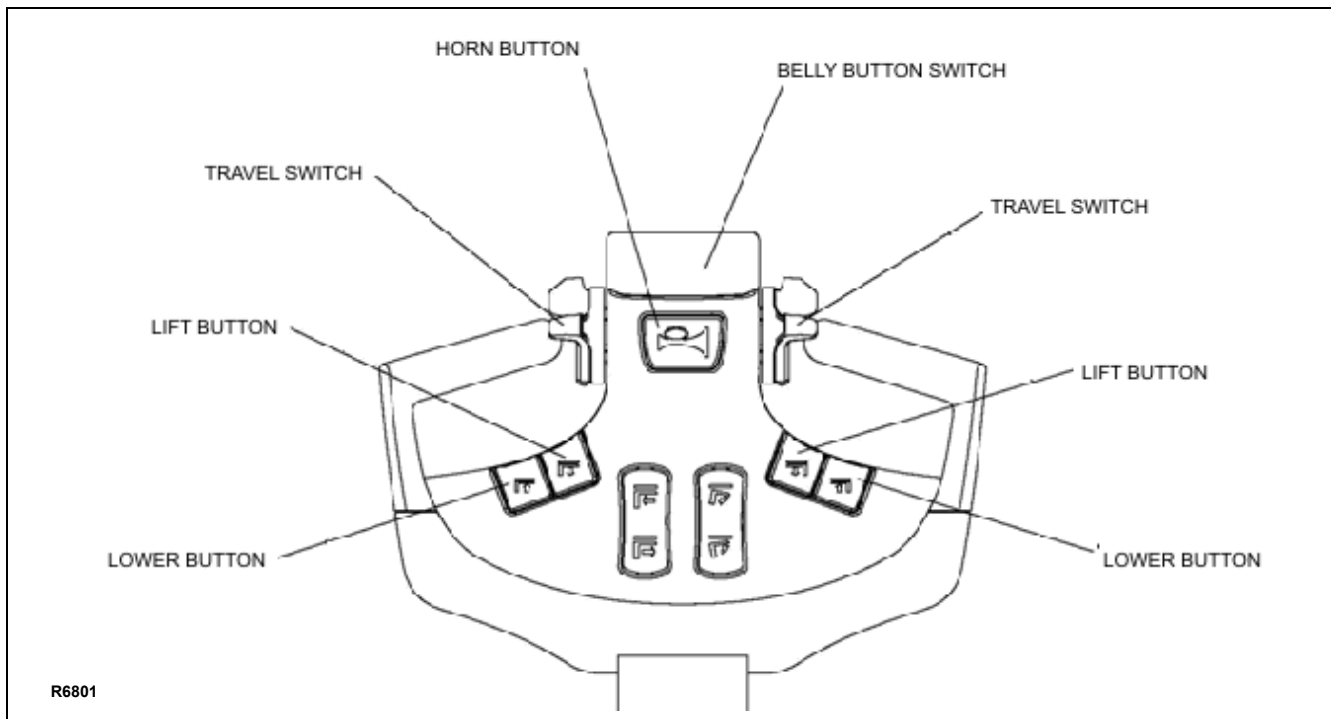

Figure 2-3 Control Head

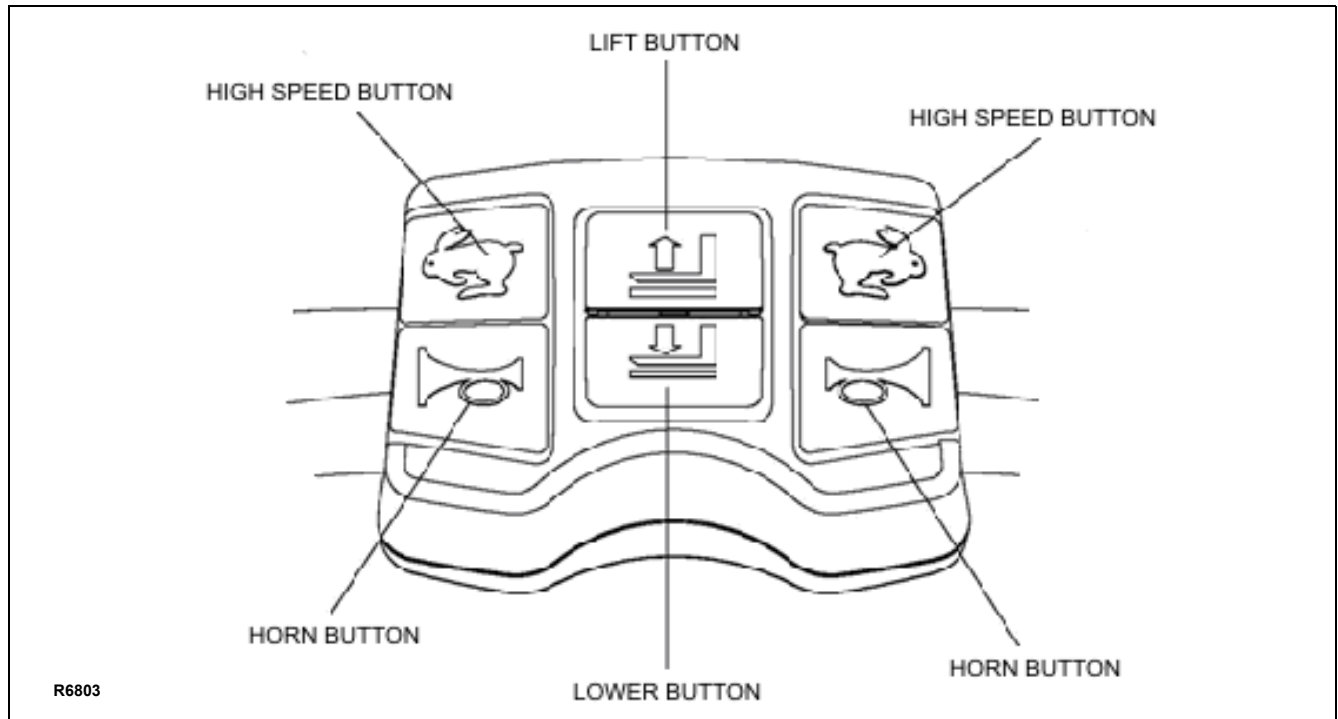

Figure 2-4 Grab Bar

2-5. STEERING ARM GAS SPRING.

The steering arm gas spring automatically raises the steering arm to the upright position when the steering arm is released. If the steering arm does not return fully, the steering arm gas spring requires replacement. Return truck to maintenance for repair.

2-6. LIFT AND LOWER CONTROLS.

Lift/Lower Control buttons are located on the steering control head. (Figure 2-3) and the grab bar (Figure 2-4).

To lift forks, push in either LIFT button and hold until forks reach desired height. To lower forks, push in either LOWER button and hold until forks descend to desired height.

2-7. LOADING AND UNLOADING.

1. Move truck to location where load is to be picked up.
2. Move the truck into position so forks are within pallet or skid, and the load is centered over the forks and as far back as possible.
3. Raise forks to lift load.
4. Drive to area where load is to be placed.
5. Move truck to align load with its new position.
6. Lower the load until it rests squarely in place and the forks are free.
7. Slowly move the truck out from under the load.

2-8. PARKING.

When finished with moving loads, return the truck to its maintenance or storage area. Turn off the key switch and disconnect the batteries. Charge batteries as necessary. Refer to battery care instructions, SECTION 3.

NOTES

SECTION 3 PLANNED MAINTENANCE

3-1. GENERAL.

Planned maintenance consists of periodic visual and operational checks, parts inspection, lubrication, and scheduled maintenance designed to prevent or discover malfunctions and defective parts. The operator performs the checks in SECTION 2, and refers any required servicing to a qualified maintenance technician who performs the scheduled maintenance and any required servicing.

3-2. MONTHLY AND QUARTERLY CHECKS.

Table 3-1 is a monthly and quarterly inspection and service chart based on normal usage of equipment eight hours per day, five days per week. If the lift truck is used in excess of forty hours per week, the frequency of inspection and service should be increased accordingly. These procedures must be performed by a qualified service technician or your Blue Giant Service Representative.

3-3. BATTERY CARE.

3-3.1. General

The EPJ-60R may be equipped with maintenance free or industrial wet cell batteries.

The care and maintenance of the battery is very important to obtain efficient truck operation and maximum battery life.

CAUTION: Gases produced by a battery can be explosive. Do not smoke, use an open flame, create an arc or sparks in the vicinity of the battery. Ventilate an enclosed area well when charging.

CAUTION: Batteries contain sulfuric acid which may cause severe burns. Avoid contact with eyes, skin or clothing. In case of contact, flush immediately and thoroughly with clean water. Obtain medical attention when eyes are affected. A baking soda solution (one pound to one gallon of water) applied to spilled acid until bubbling stops, neutralizes the acid for safe handling and disposal.

Leakage voltage from battery terminals to battery case can cause misleading trouble symptoms with the truck electrical system. Since components of the truck electrical system are insulated from truck frame, leakage voltage will not normally affect truck operation unless a short circuit or breakdown of circuit wire insulation to truck frame occurs.

A voltage check from battery connector terminal to battery case should indicate near zero volts. Typically, however, the sum of the voltages at both terminals will equal battery volts. This leakage voltage will discharge the battery. As battery cleanliness deteriorates, the usable charge of the battery decreases due to this self discharge.

Table 3-1 Monthly and Quarterly Inspection and Service Chart

| VISUAL CHECKS | |
|---------------|-----------------------------------------------------------------------------------------------------------------------------------|
| INTERVAL | INSPECTION OR SERVICE |
| Monthly | Check electrical brake for proper operation. |
| Monthly | Check load wheels for wear. A poly load wheel must be replaced if worn to within 1/16 inch of hub. Check for separation from hub. |
| Monthly | Check drive wheel for wear. A poly drive wheel must be replaced if worn to within 3/4 inch of hub. Check for separation from hub. |
| Monthly | Inspect wiring for loose connections and damaged insulation. |
| Monthly | Inspect contactors for proper operation. |
| Monthly | Check deadman brake switch for proper operation. |
| Quarterly | Check lift cylinder for leakage. |
| Quarterly | Check for excessive jerking of steering arm when stopping or starting. |

Although a leakage voltage reading of zero volts may not be possible, a cleaner battery will have more usable charge for truck operation and not affect operation of electronic devices on the unit.

3-3.2. Safety Rules

- Wear protective clothing, such as rubber apron, gloves, boots and goggles when performing any maintenance on batteries. Do not allow electrolyte to come in contact with eyes, skin, clothing or floor. If electrolyte comes in contact with eyes, flush immediately and thoroughly with clean water. Obtain medical attention immediately. Should electrolyte be spilled on skin, rinse promptly with clean water and wash with soap. A baking soda solution (one pound to one gallon of water) will neutralize acid spilled on clothing, floor or any other surface. Apply solution until bubbling stops and rinse with clean water.
- If truck is equipped with wet cell batteries, keep vent plugs firmly in place at all times except when adding water or taking hydrometer readings. Do not allow dirt, cleaning solution or other foreign material to enter cells. Impurities in electrolyte has a neutralizing effect reducing available charge.
- Do not bring any type of flame, spark, etc., near the battery. Gas formed while the battery is charging, is highly explosive. This gas remains in cell long after charging has stopped.
- Do not lay metallic or conductive objects on battery. Arcing will result.
- Do not touch non-insulated parts of DC output connector or battery terminals to avoid possible electrical shock.
- De-energize all AC and DC power connections before servicing battery.
- Do not charge a frozen battery.
- Do not use charger if it has been dropped or otherwise damaged.

3-3.3. Battery Care and Charging

CAUTION: Never smoke or bring open flame near the battery. Gas formed during charging is highly explosive and can cause serious injury.

1. Charge the battery only in areas designated for that use.
2. Make certain the charger being used matches the voltage and amperage of the truck battery.
3. Before disconnecting or connecting batteries to a charger, make sure the charger is "OFF". If an attempt is made to do this while the charger is "ON", serious injury to you, the battery and the charger could result.
4. Before connecting the battery cable to the trucks receptacle, make sure the key switch is off. The battery cable must be fully connected before the truck is used. If the plug is not making good contact, heat will weld the two parts of the battery connector together, making it difficult to remove and necessary to replace.
5. Battery terminals should be checked and cleaned of corrosion regularly. Good battery terminal contact is essential not only for operation, but also for proper charging of the battery.
6. The charging requirements will vary depending on the use of the truck. The battery should be given as equalizing charge on a weekly basis. This charge should normally be an additional three hours at the finish rate.
7. Make certain battery used meets weight and size requirements of truck. NEVER operate truck with an undersized battery.

3-3.4. Battery Cleaning

Always keep vent plugs tightly in place when cleaning battery. When properly watered and charged, the battery will remain clean and dry. All that is necessary is to brush or blow off any dust or dirt that may accumulate on them. However, if electrolyte is spilled or overflows from a cell, it should be neutralized with a solution of baking soda and water, brushing the soda solution beneath the connectors and removing grime from the covers. Then rinse the battery with cool water from a low pressure supply to remove the soda and loosen dirt. If batteries stay wet consistently, they may be either overcharged or over filled. This condition should be investigated and corrected.

3-3.5. MAINTENANCE FREE BATTERIES

Some trucks may be equipped with maintenance free batteries. These batteries are completely sealed, will not require any watering and have a full 80% discharge available.

Sealed Maintenance Free batteries contain a pressure release valve and under normal operating conditions do not require any special ventilation.

CAUTION: Do not try to open this battery or remove the pressure release valve.

Only under severe overcharging, such as connected to an improperly sized charger, will any significant amount of gasses be released from the battery. Also, being a valve regulated battery, it never requires watering.

3-4. CHARGING BATTERIES

Charging requirements will vary depending on depth of discharge and temperature. Follow safety rules when placing a battery on charge.

Proceed as follows:

1. Park truck at charging station with carriage lowered and turn the key switch off.
2. Check the condition of the AC cord, the battery connector and battery cables. If there are any cuts in the cable, any exposed wires, loose plugs or connectors, **DO NOT** attempt to charge the batteries. Contact appropriate personnel for repairs to be made.
3. Disconnect the batteries from the truck and connect the batteries to the charger. Make sure connectors are mated properly.
4. Connect the charger to the appropriate power supply.
5. Follow the instructions for the charger being used.

| | |
|-----------------------------------------------------------------------------------------------------------------|----------------------------------------------------------------------------------------------------------------------------------------------------------------------------------------------------------------------------------------------------------------------------------------------------------------------------------------------------------------------------------------------------------------------------------------------------------------------------------------------------------------------------------------------------------------------------------|
| <p>BATTERY HAZARD</p>  | <p>! DANGER</p> <p>EXPLOSIVE/POISON/CAUSTIC NO SPARKS, FLAMES, SMOKING BATTERY ACID can cause blindness and severe burns SHIELD EYES, AVOID SKIN CONTACT IF SPLASHED flush immediately with water, get medical help fast.</p> <p>Do not service battery while on charge. Do not connect or disconnect battery from charger while charger is on. Only qualified and experienced personnel should perform maintenance and repair on batteries. Use caution while servicing or removing battery. (Refer to Battery Safety Sheet).</p> |
|-----------------------------------------------------------------------------------------------------------------|----------------------------------------------------------------------------------------------------------------------------------------------------------------------------------------------------------------------------------------------------------------------------------------------------------------------------------------------------------------------------------------------------------------------------------------------------------------------------------------------------------------------------------------------------------------------------------|

3-5. LUBRICATION.

Refer to [Table 3-2](#) for the recommended types of grease and oil. [Table 3-3](#) in conjunction with [Figure 3-1](#) identifies the items requiring lubrication.

**Table 3-2 Recommended Lubricants
(See [Table 3-3](#) for Application)**

| | |
|-------|---------------------------------------------------------------------------------------------------------------------------------------------------------------------------------------------------------------------------------------|
| No. 1 | Transmission oil—EP SAE 80W-90 Transmission oil—EP SAE 10W-30 (Note) |
| No. 2 | Grease—Lithium base, general purpose. |
| No. 3 | Hydraulic oil-Heavy duty with a viscosity of 150 SUS foam suppressing agent and rust and oxidation inhibitors Hydraulic oil-Heavy duty with a viscosity of 100 SUS foam suppressing agent and rust and oxidation inhibitors (Note) |
| No. 4 | SAE 30 or 40 Engine lubricating oil |

NOTE: USED ON COLD CONDITIONED TRUCKS

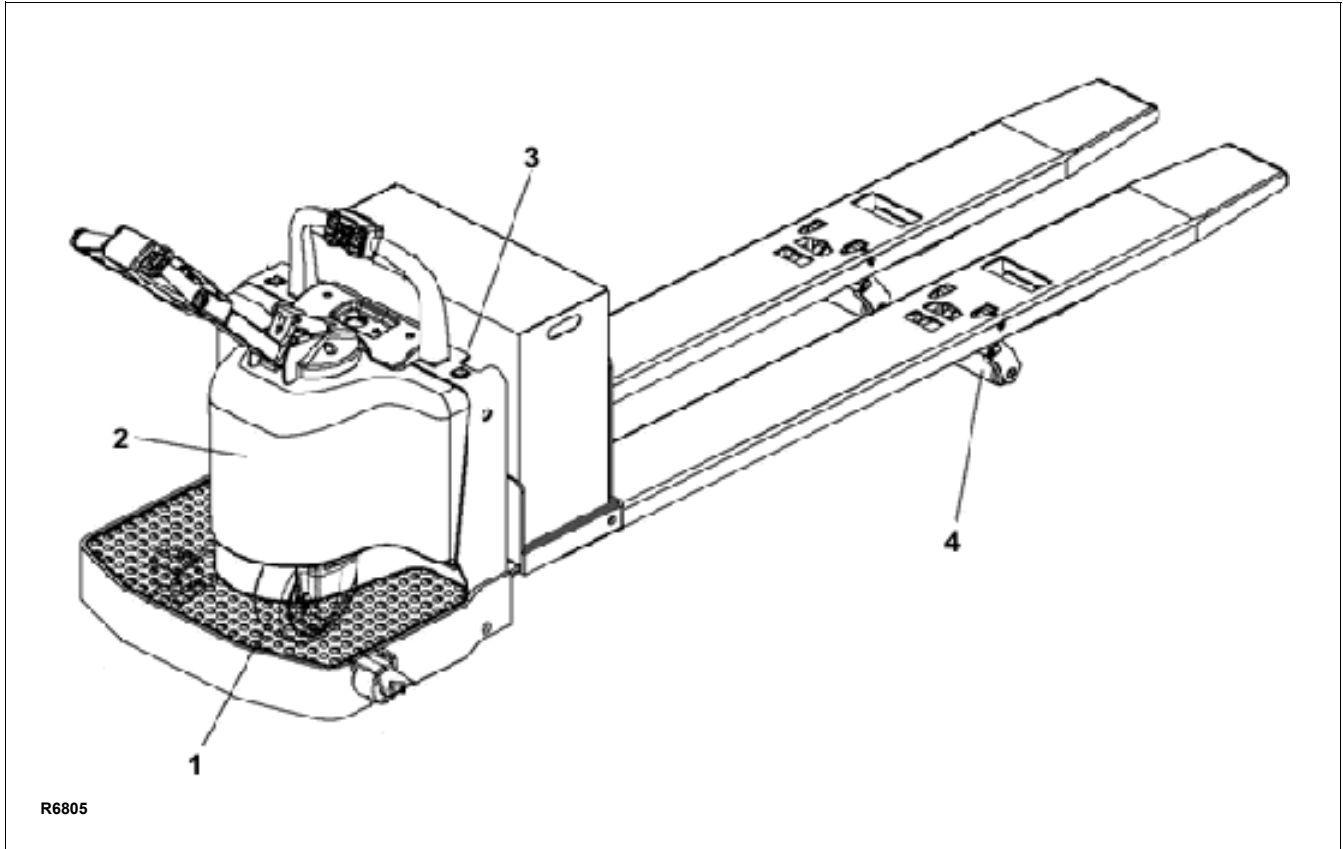

Figure 3-1 Lubrication Diagram

Table 3-3 Lubrication Chart

| FIG 3-2 INDEX NO. | LOCATION | METHOD OF APPLICATION | TYPE (Table 3-3) | APPLICATION OF LUBRICANT |
|--------------------------|------------------------------------------|------------------------------|-------------------------|---------------------------------------------------------------------------------------------|
| 1 | Transmission Capacity 2 pints | Can | No. 1 | Fill to level plug opening |
| 2 | Hydraulic Reservoir Capacity-1 quarts | Can | No. 3 | With lift carriage fully lowered, fill reservoir with hydraulic oil to 1 inch below opening |
| 3 | Lift Linkage Fittings | Gun | No. 2 | Pressure lubricate. |
| 4 | Lift Linkage Fittings* | Gun | No. 2 | Pressure lubricate. |

* Raise lift carriage to gain access to grease fittings.

NOTES

SECTION 4 TROUBLESHOOTING

4-1. GENERAL

Use [Table 4-1](#) as a guide to determine possible causes of trouble. The table is divided into five main categories: Truck and Hydraulic System Will Not

Operate: Truck Does Not Operate Forward or Reverse: Trouble With Braking: Trouble With Lifting Or Lowering, and Miscellaneous malfunctions.

Table 4-1 Troubleshooting Chart

| MALFUNCTION | PROBABLE CAUSE | CORRECTIVE ACTION |
|----------------------------------------------------------------------------------------------------------------------------------------------------------------------------------------------------------------------------------------------------------------------------------------------------------------------------------------------|---------------------------------------------------------------------------------------------------------------------------------------------------------------------------------------------------------------------------------------------------------------------------------------------------------------------------------------------------------------------------------------------------------------------------------------------------------------------------------------------------------------------------------------------------------|----------------------------------------------------------------------------------------------------------------------------------------------------------------------------------------------------------------------------------------------------------------------------------------------------------------------------------------------------------------------------------------------------|
| <p>TRUCK AND HYDRAULIC SYSTEM WILL NOT OPERATE</p> <p>Truck will not travel nor will lift system operate.</p> | <p>a. Fuses (7, Figure 12-14) blown.</p> <p>b. Battery dead or disconnected.</p> <p>c. Keyswitch (13, Figure 12-13) defective.</p> <p>d. Defective wiring.</p> | <p>Check fuses and replace if necessary.</p> <p>Check battery quick-disconnect plug and check battery voltage.</p> <p>Bypass keyswitch to determine if it is malfunctioning.</p> <p>Check for open circuit. Repair as required.</p> |
| <p>TRUCK DOES NOT OPERATE FORWARD OR REVERSE</p> <p>Truck does not travel forward or reverse. All other functions operate normally.</p> <p>Truck travels forward but not in reverse.</p> <p>Truck travels reverse but not in forward.</p> <p>Truck travels forward and in reverse at lower speeds; will not travel at high speed.</p> | <p>a. Check all wiring. A loose connection may be the cause of malfunction.</p> <p>b. Defective deadman switch (30, Figure 12-2).</p> <p>c. Defective main contactor (15, Figure 12-14).</p> <p>d. Defective potentiometer (10, Figure 12-3).</p> <p>Defective potentiometer (10, Figure 12-3) in control head.</p> <p>Defective potentiometer (10, Figure 12-3) in control head.</p> <p>Defective potentiometer (10, Figure 12-3) in control head.</p> | <p>Tighten all loose connections before further troubleshooting.</p> <p>Check and replace switch if defective.</p> <p>Check for proper operation and replace if necessary.</p> <p>Check and replace potentiometer if defective.</p> <p>Check and replace potentiometer if defective.</p> <p>Check and replace potentiometer if defective.</p> <p>Check and replace potentiometer if defective.</p> |
| <p>TROUBLE WITH BRAKING</p> <p>Truck does not slow with brake, or brake does not engage.</p> | <p>a. Defective deadman switch (29, Figure 12-2).</p> <p>b. Defective electric brake (49, Figure 12-6).</p> | <p>Check deadman switch for continuity. If none found when the control arm is in the brake position, replace switch.</p> <p>Adjust or replace brake.</p> |

Table 4-1 Troubleshooting Chart - Continued

| MALFUNCTION | PROBABLE CAUSE | CORRECTIVE ACTION |
|------------------------------------------------------------------------------------------------------------------------------------------------------------------------------------------------------------------------------------------------------------------------------------------------------|-------------------------------------------------------------------------------------------------------------------------------------------------------------------------------------------------------------------------------------------------------------------------------------------------------------------------------------------------------------------------------------------------------------------------------------------------------------|--------------------------------------------------------------------------------------------------------------------------------------------------------------------------------------------------------------------------------------------------------------------------------------------------------------------------------------------------------------------------------------------------------------------------------------------------------------------------------------------------------------|
| <p>TROUBLE WITH BRAKING - Continued</p> <p>Brake will not release.</p> <p>Brake drags.</p> <p>Brake grabs.</p> <p>Abnormal noise and chatter when brake is applied.</p> | <p>a. Air gap more than 0.01 in (0.25mm).</p> <p>b. Brake temperature above 281° F (140° C).</p> <p>c. Open brake circuitry or wiring.</p> <p>a. Air gap more than 0.01 in (0.25mm).</p> <p>b. Defective electric brake (49, Figure 12-6).</p> <p>a. Air gap more than 0.01 in (0.25mm).</p> <p>b. Defective electric brake (49, Figure 12-6).</p> <p>Defective electric brake (49, Figure 12-6).</p> | <p>Adjust</p> <p>Allow to cool and check air gap.</p> <p>Make voltage checks.</p> <p>Adjust</p> <p>Replace.</p> <p>Adjust</p> <p>Replace.</p> <p>Replace.</p> |
| <p>TROUBLE WITH LIFTING OR LOWERING</p> <p>Oil sprays or flows from the top of the lift cylinder.</p> <p>Squealing sounds when lifting forks.</p> <p>Forks do not lift to top.</p> <p>Weak, slow or uneven action of hydraulic system.</p> <p>Forks do not lift, pump motor does not run.</p> | <p>Defective packing in lift cylinder</p> <p>a. Oil level too low.</p> <p>b. Lift linkage binding.</p> <p>Oil level too low.</p> <p>a. Defective pump or relief valve.</p> <p>b. Worn lift cylinder.</p> <p>c. Load larger than capacity.</p> <p>d. Defective lift motor solenoid.</p> <p>e. Battery charge low.</p> <p>a. Battery is dead or disconnected.</p> <p>b. Defective wiring.</p> <p>c. Defect in electrical system for operating pump motor.</p> | <p>Repair lift cylinder.</p> <p>Identify oil leak.</p> <p>Apply grease.</p> <p>Add oil to reservoir.</p> <p>Check pressure. Adjust as necessary.</p> <p>Replace cylinder.</p> <p>Refer to I.D.plate for capacity.</p> <p>Replace solenoid (5, Figure 12-11) on electrical panel.</p> <p>Charge battery.</p> <p>Check and recharge if required.</p> <p>Check and repair as required.</p> <p>Check lift switch in control head, as well as the solenoid (5, Figure 12-11).</p> |
| <p>Forks do not lift, motor runs.</p> | <p>Defect in hydraulic system.</p> | <p>Check the oil level in the reservoir and the oil lines to the lift cylinder, and repair as required. If normal, check the hydraulic pump, and relief valve. Repair, or adjust.</p> |

Table 4-1 Troubleshooting Chart - Continued

| MALFUNCTION | PROBABLE CAUSE | CORRECTIVE ACTION |
|--------------------------------------------------------------------------------------------------------------------------------------------------------------------------------------------------------------------------------------------------------|-------------------------------------------------------------------------------------------------------------------------------------------------------------------------------------------------------------------------------------------------------------------------------------------------------|------------------------------------------------------------------------------------------------------------------------------------------------------------------------------------------------------------------------------------------------------------------------------------------------------------------------------------------------------------------------------------------------------------------------------------------------------------------------------------------------------------------------------------------|
| <p>TROUBLE WITH LIFTING OR LOWERING - Continued</p> <p>Forks lift, but will not go down.</p> <p>Load will not hold</p> <p>Platform does not lift to top. Pump motor runs.</p> <p>Forks creep downward under load when in a raised position.</p> | <p>Defect in hydraulic system</p> <p>a. Oil bypassing internally in control valve</p> <p>b. Worn lift cylinder or packing.</p> <p>a. Oil level too low.</p> <p>b. Load larger than capacity.</p> <p>c. Batteries need charging.</p> <p>Leak in hydraulic system, lift cylinder or lowering valve.</p> | <p>Check lowering control switch in control head and lowering solenoid on valve assembly (11, Figure 12-11). Replace as required.</p> <p>Replace valve assembly (11, Figure 12-11).</p> <p>Repack cylinder.</p> <p>Add oil to reservoir.</p> <p>Refer to nameplate on side of mast for maximum load capacity.</p> <p>Change batteries.</p> <p>Check for leaking fitting in hydraulic line and repair as required. Repack lift cylinder or replace valve assembly (11, Figure 12-11).</p> |
| <p>MISCELLANEOUS</p> <p>Steering arm does not return to the upright position.</p> <p>Truck moves forward when arm is pulled down.</p> <p>Steering arm jerks excessively starting or stopping the truck.</p> <p>Drive motor is jerky.</p> | <p>a. Weak return spring.</p> <p>b. Binding.</p> <p>a. Belly-button switch defective.</p> <p>b. Short in control head.</p> <p>Drive wheel worn.</p> <p>Motor internally damaged or worn.</p> | <p>Replace spring.</p> <p>Check and free the binding item. Verify that the cable has not been damaged. Repair or replace as needed.</p> <p>Check for short, and repair or replace as necessary.</p> <p>Check wiring and repair as required.</p> <p>Replace drive wheel if worn to within 3/4 inch of hub.</p> <p>Replace motor.</p> |

4-2. CONTROLLER TROUBLESHOOTING.

An internal microcontroller automatically maintains surveillance over the functioning of the controller.

If the fault is critical, the controller is disabled. More typically, the fault is a remediable condition - for example - an undervoltage fault is cleared when the condition is removed.

4-2.1. Zapi Can Console Kit

A Zapi Can Console kit is available that is designed specifically for use with the Zapi controller. It serves multiple functions of reading diagnostic data, testing truck operation, setting options, adjustments and parameter changes of the controller. The Zapi Can Console kit contains a Dongle IXXAT Cable and flash drive containing the computer files required. The kit is available through your Blue Giant dealer. If you require dealer location information, contact Blue Giant.

Load the program onto a laptop computer. Connect the computer to the controller with the supplied cable as shown in [Figure 4-1](#).



Figure 4-1 Connecting the Handset

Click on the ZAPI Can Console icon. On the ZAPI PC Can Console screen, click on the **Configuration** button and then Can Device button (See [Figure 4-2](#)).



Figure 4-2 ZAPI PC Can Console Screen

On the Device Configuration screen click on **OK** (See [Figure 4-3](#)).



Figure 4-3 Device Configuration Screen

On the Configuration Can screen click on **OK** (See [Figure 4-4](#)).



Figure 4-4 Configuration Can Screen

On the Can Hardware screen click on **OK** (See [Figure 4-5](#)).



Figure 4-5 Can Hardware Screen

On the Configuration Can screen click on **OK** (See [Figure 4-6](#)).



Figure 4-6 Configuration Can Screen

On the ZAPI PC Can Console screen, click on the **Start** button (See [Figure 4-7](#)).



Figure 4-7 ZAPI PC Can Console Screen

On the Set Node screen click on **NODE 2 Traction** and then click on **OK** (See [Figure 4-8](#)).



Figure 4-8 Set Node Screen

On the ZAPI PC Can Console screen click on **Configuration** and then click on **Enter Password** (See [Figure 4-9](#)).



Figure 4-9 ZAPI PC Can Console Screen

On the Insert Password screen enter **ZAPI** in all caps and then click on **OK** (See [Figure 4-10](#)).



Figure 4-10 Password Screen

On the Parameters screen (Figure 4-15) click on **Receive** button. The screen will then list the **Parameter Name** along with the current **Parameter Value**. Use the - and + to change the parameter.

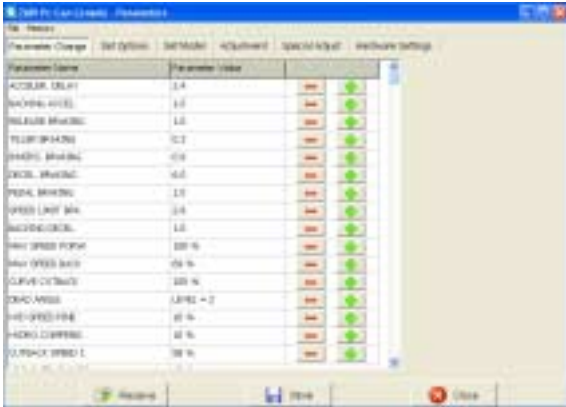

Figure 4-15 Parameters Screen

If you feel that one of the other parameters has been changed accidentally, check that setting against Table 4-3.

Click on button the **Store** button to save the changes. Click on button the **Store** button to save the changes.

Table 4-2 Adjustment Settings

| Code | Function | Setting |
|------|-----------------|---------|
| 0 | ACCELER. DELAY | 24 |
| 11 | RELEASE BRAKING | 20 |
| 220 | TILLER BRAKING | 3 |
| 12 | INVERS. BRAKING | 20 |
| 237 | DECEL. BRAKING | 90 |
| 30 | MAX SPEED FORW | 100 |
| 31 | MAX SPEED BACK | 69 |

Table 4-3 Factory Setting

| Code | Name | Position | Menu | Value | Scaled Value | Code Open | Node |
|------|-------------------|----------|------|-------|--------------|-----------|------|
| 0 | ACCELER. DELAY | 0 | 0 | 24 | 2.4 | 0 | 2 |
| 165 | BACKING ACCEL. | 1 | 0 | 10 | 1 | 0 | 2 |
| 11 | RELEASE BRAKING | 2 | 0 | 20 | 2 | 0 | 2 |
| 220 | TILLER BRAKING | 3 | 0 | 3 | 0.3 | 0 | 2 |
| 12 | INVERS. BRAKING | 4 | 0 | 20 | 2 | 0 | 2 |
| 237 | DECEL. BRAKING | 5 | 0 | 90 | 9 | 0 | 2 |
| 13 | PEDAL BRAKING | 6 | 0 | 3 | 0.3 | 0 | 2 |
| 16 | SPEED LIMIT BRK. | 7 | 0 | 28 | 2.8 | 0 | 2 |
| 164 | BACKING DECEL. | 8 | 0 | 10 | 1 | 0 | 2 |
| 30 | MAX SPEED FORWARD | 9 | 0 | 10 | 100% | 0 | 2 |
| 31 | MAX SPEED BACK | 10 | 0 | 69 | 69% | 0 | 2 |
| 29 | CURVE CUTBACK | 11 | 0 | 100 | 100% | 0 | 2 |
| 252 | DEAD ANGLE | 12 | 0 | 2 | LEVEL=2 | 0 | 2 |
| 48 | HYD SPEED FINE | 13 | 0 | 16 | 16% | 0 | 2 |
| 49 | HYDRO COMPENS. | 14 | 0 | 10 | 10% | 0 | 2 |
| 21 | CUTBACK SPEED 1 | 15 | 0 | 58 | 58% | 0 | 2 |
| 181 | H&S CUTBACK/CB2 | 16 | 0 | 18 | 18% | 0 | 2 |
| 217 | FREQUENCY CREEP | 17 | 0 | 12 | 1.20 Hz | 0 | 2 |
| 63 | MAXIMUM CURRENT | 18 | 0 | 100 | 100% | 0 | 2 |
| 209 | ACC SMOOTH | 19 | 0 | 10 | 1 | 0 | 2 |
| 210 | INV SMOOTH | 20 | 0 | 10 | 1 | 0 | 2 |
| 211 | STOP SMOOTH | 21 | 0 | 10 | 10Hz | 0 | 2 |
| 213 | BRK SMOOTH | 22 | 0 | 10 | 1 | 0 | 2 |

Table 4-3 Factory Setting-Continued

| Code | Name | Position | Menu | Value | Scaled Value | Code Open | Node |
|-------------|-------------------|-----------------|-------------|--------------|---------------------|------------------|-------------|
| 215 | STOP BRK SMOOTH | 23 | 0 | 10 | 10Hz | 0 | 2 |
| 253 | BACKING SPEED | 24 | 0 | 27 | 27% | 0 | 2 |
| 59 | BACKING TIME | 25 | 0 | 10 | 10 | 0 | 2 |
| 56 | AUXILIARY TIME | 26 | 0 | 30 | 3 | 0 | 2 |
| 57 | HYDRO TIME | 27 | 0 | 3 | 1.5 | 0 | 2 |
| 65 | PUMP IMAX | 28 | 0 | 9 | LEVEL=9 | 0 | 2 |
| 1 | PU. ACCELER. DEL | 29 | 0 | 15 | 15 | 0 | 2 |
| 6 | PU. DECELER. DEL | 30 | 0 | 15 | 1.5 | 0 | 2 |
| 26 | SPEED LIMIT | 31 | 0 | 100 | 100% | 0 | 2 |
| 27 | CREEP SPEED | 32 | 0 | 10 | 10% | 0 | 2 |
| 53 | COMPENSATION | 33 | 0 | 10 | 10% | 0 | 2 |
| 246 | MIN EVP | 34 | 0 | 16 | 6.3 | 0 | 2 |
| 245 | MAX EVP | 35 | 0 | 249 | 97.6 | 0 | 2 |
| 244 | MIN EVP2 | 36 | 0 | 16 | 6.3 | 0 | 2 |
| 243 | MAX EVP2 | 37 | 0 | 249 | 97.6 | 0 | 2 |
| 250 | EVP OPEN DELAY | 38 | 0 | 16 | 0.8 | 0 | 2 |
| 249 | EVP CLOSE DELAY | 39 | 0 | 16 | 0.8 | 0 | 2 |
| 248 | EVP OPEN DELAY2 | 40 | 0 | 16 | 0.8 | 0 | 2 |
| 247 | EVP CLOSE DELAY2 | 41 | 0 | 16 | 0.8 | 0 | 2 |
| 190 | TILLER SWITCH | 0 | 1 | 1 | SEAT | 0 | 2 |
| 251 | EPS | 1 | 1 | 0 | OFF | 0 | 2 |
| 125 | HOUR COUNTER | 2 | 1 | 0 | RUNNING | 0 | 2 |
| 230 | EVP TYPE | 3 | 1 | 1 | DIGITAL | 0 | 2 |
| 235 | EVP2 TYPE | 4 | 1 | 0 | NONE | 0 | 2 |
| 121 | BATTERY CHECK | 5 | 1 | 1 | LEVEL=1 | 0 | 2 |
| 233 | STOP ON RAMP | 6 | 1 | 0 | OFF | 0 | 2 |
| 100 | QUICK INVERSION | 7 | 1 | 2 | TIMED | 0 | 2 |
| 241 | SET MOT. TEMPERAT | 8 | 1 | 2 | ANALOG | 0 | 2 |
| 212 | EVI-5 | 9 | 1 | 1 | DIGITAL | 0 | 2 |
| 218 | EV2 | 10 | 1 | 0 | ABSENT | 0 | 2 |
| 219 | EV3 | 11 | 1 | 0 | ABSENT | 0 | 2 |
| 216 | EV4 | 12 | 1 | 0 | ABSENT | 0 | 2 |
| 183 | DIAG PED WIRE KO | 13 | 1 | 0 | ABSENT | 0 | 2 |
| 236 | INVERSION MODE | 14 | 1 | 1 | ON | 0 | 2 |
| 170 | H&S FUNCTION | 15 | 1 | 1 | PRESENT | 0 | 2 |
| 180 | HYDRO FUNCTION | 16 | 1 | 0 | NONE | 0 | 2 |
| 185 | M.C. FUNCTION | 17 | 1 | 1 | PRESENT | 0 | 2 |

Table 4-3 Factory Setting-Continued

| Code | Name | Position | Menu | Value | Scaled Value | Code Open | Node |
|-------------|------------------|-----------------|-------------|--------------|---------------------|------------------|-------------|
| 239 | AUX OUT FUNCTION | 18 | 1 | 1 | PRESENT | 0 | 2 |
| 182 | CONNECTED TO | 0 | 2 | 2 | TRACTION | 0 | 2 |
| 145 | SET BATTERY TYPE | 0 | 3 | 0 | 24V | 0 | 2 |
| 140 | ADJUST BATTERY | 1 | 3 | 139 | 23.66V | 0 | 2 |
| 221 | THROTTLE 0 ZONE | 2 | 3 | 5 | 5% | 0 | 2 |
| 224 | THROTTLE X POINT | 3 | 3 | 40 | 40% | 0 | 2 |
| 225 | THROTTLE Y POINT | 4 | 3 | 60 | 60% | 0 | 2 |
| 178 | BAT. MIN ADJ. | 5 | 3 | 0 | LEVEL=0 | 0 | 2 |
| 177 | BAT. MAX ADJ. | 6 | 3 | 2 | LEVEL=2 | 0 | 2 |
| 234 | LOAD HM FROM MDI | 7 | 3 | 0 | OFF | 0 | 2 |
| 228 | CHECK UP DONE | 8 | 3 | 0 | OFF | 0 | 2 |
| 229 | CHECK UP TYPE | 9 | 3 | 0 | NONE | 0 | 2 |
| 184 | MC EB VOLT | 10 | 3 | 100 | 100% | 0 | 2 |
| 186 | MC EB RID | 11 | 3 | 85 | 85% | 0 | 2 |
| 188 | PWM ON MAIN CONT | 12 | 3 | 1 | ON | 0 | 2 |
| 189 | PWM ON AUX OUT | 13 | 3 | 1 | ON | 0 | 2 |
| 159 | ADJUSTMENT #01 | 0 | 131 | 56 | 90% | 0 | 2 |
| 158 | ADJUSTMENT #02 | 1 | 131 | 57 | 91% | 0 | 2 |
| 142 | SET CURRENT | 2 | 131 | 32 | 320A | 0 | 2 |
| 141 | SET TEMPERATURE | 3 | 131 | 107 | 38 | 0 | 2 |
| 157 | ADJUSTMENT #3 | 4 | 131 | 50 | 50% | 0 | 2 |
| 242 | SET CURRENT PUMP | 5 | 131 | 28 | 280A | 0 | 2 |
| 214 | HIGH ADDRESS | 6 | 131 | 0 | 0 | 0 | 2 |
| 232 | DITHER AMPLITUDE | 7 | 131 | 2 | 2.50% | 0 | 2 |
| 231 | DITHER FREQUENCY | 8 | 131 | 5 | 32.2 Hz | 0 | 2 |
| 187 | POSITIVE E.B. | 0 | 129 | 0 | LEVEL=0 | 0 | 2 |
| 179 | TOP MAX SPEED | 1 | 129 | 135 | 135 Hz | 0 | 2 |
| 240 | TRUCK TYPE | 2 | 129 | 0 | LEVEL=0 | 0 | 2 |
| 53 | COMPENSATION | 3 | 129 | 1 | ON | 0 | 2 |
| 277 | CLIP CONTROL | 4 | 129 | 1 | ON | 0 | 2 |
| 171 | DC-LINK COMPENS. | 5 | 129 | 1 | ON | 0 | 2 |
| 172 | SAT FREQUENCY | 6 | 129 | 80 | 80 Hz | 0 | 2 |
| 14 | BRAKING MODUL. | 7 | 129 | 80 | 80 Hz | 0 | 2 |
| 226 | MINIMUM VOLTAGE | 8 | 128 | 4 | 1.60% | 0 | 2 |
| 222 | BOOST AT LO FREQ | 9 | 129 | 20 | 20% | 0 | 2 |
| 173 | BOOST AT HI FREQ | 10 | 129 | 50 | 50% | 0 | 2 |
| 174 | BOOST CORNER FRE | 11 | 129 | 40 | 40 Hz | 0 | 2 |

Table 4-3 Factory Setting-Continued

| Code | Name | Position | Menu | Value | Scaled Value | Code Open | Node |
|-------------|------------------|-----------------|-------------|--------------|---------------------|------------------|-------------|
| 175 | BRAKING BOOSTER | 12 | 129 | 0 | 0% | 0 | 2 |
| 238 | MOTORRESISTANCE | 13 | 129 | 0 | LEVEL=0 | 0 | 2 |
| 176 | SLIP COEFFICIENT | 14 | 129 | 0 | LEVEL=0 | 0 | 2 |
| 233 | MAXSLIP RESET | 15 | 129 | 6 | 0.60 Hz | 0 | 2 |
| 191 | MAXSLIP 0 | 16 | 129 | 25 | 2.5 Hz | 0 | 2 |
| 192 | MAXSLIP 1 | 17 | 129 | 25 | 2.5 Hz | 0 | 2 |
| 166 | MAXSLIP 1 REV | 18 | 129 | 25 | 2.5 Hz | 0 | 2 |
| 196 | FREQSLIP 1 | 19 | 129 | 30 | 30 Hz | 0 | 2 |
| 193 | MAXSLIP 2 | 20 | 129 | 30 | 3.0 Hz | 0 | 2 |
| 167 | MAXSLIP 2 REV. | 21 | 129 | 22 | 2.2 Hz | 0 | 2 |
| 197 | FREQSLIP 2 | 22 | 129 | 55 | 55 Hz | 0 | 2 |
| 194 | MAXSLIP 3 | 23 | 129 | 47 | 4.7 Hz | 0 | 2 |
| 168 | MAXSLIP 3 REV. | 24 | 129 | 22 | 2.2 Hz | 0 | 2 |
| 198 | FREQSLIP 3 | 25 | 129 | 80 | 80 Hz | 0 | 2 |
| 195 | MAXSLIP 4 | 26 | 129 | 47 | 4.7 Hz | 0 | 2 |
| 169 | MAXSLIP 4 REV. | 27 | 129 | 22 | 2.2 Hz | 0 | 2 |
| 199 | FREQSLIP 4 | 28 | 129 | 130 | 130 Hz | 0 | 2 |
| 200 | MAXSLIP 0 BRK | 2 | 129 | 25 | 2.5 Hz | 0 | 2 |
| 201 | MAXSLIP 1 BRK | 30 | 129 | 25 | 2.5 Hz | 0 | 2 |
| 205 | FREQSLIP 1 BRK | 31 | 129 | 30 | 30 Hz | 0 | 2 |
| 202 | MAXSLIP 2 BRK | 23 | 129 | 30 | 3.0 Hz | 0 | 2 |
| 206 | FREQSLIP 2 BRK | 33 | 129 | 60 | 60 Hz | 0 | 2 |
| 203 | MAXSLIP 3 BRK | 34 | 129 | 40 | 4.0 Hz | 0 | 2 |
| 207 | FREQSLIP 3 BRK | 35 | 129 | 100 | 100 Hz | 0 | 2 |
| 204 | MAXSLIP 4 BRK | 36 | 129 | 40 | 4.0 Hz | 0 | 2 |
| 208 | FREQSLIP 4 BRK | 37 | 129 | 130 | 130 Hz | 0 | 2 |
| 93 | OPTION 07 | 38 | 129 | 1 | LEVEL=1 | 0 | 2 |
| 92 | OPTION 08 | 39 | 129 | 6 | LEVEL=6 | 0 | 2 |
| 94 | OPTION 06 | 40 | 129 | 6 | LEVEL=6 | 0 | 2 |

SECTION 5 STEERING ARM, CONTROL HEAD AND COMPARTMENT

5-1. CONTROL HEAD

5-1.1. Cover Removal.

1. Turn off the key switch (13, [Figure 12-13](#)) and disconnect the batteries.
2. Remove two screws (5, [Figure 5-2](#)) and two screws (6) and lift up cover (4) and disconnect harness (27, [Figure 5-1](#)) from switch harness (21, [Figure 5-2](#)).

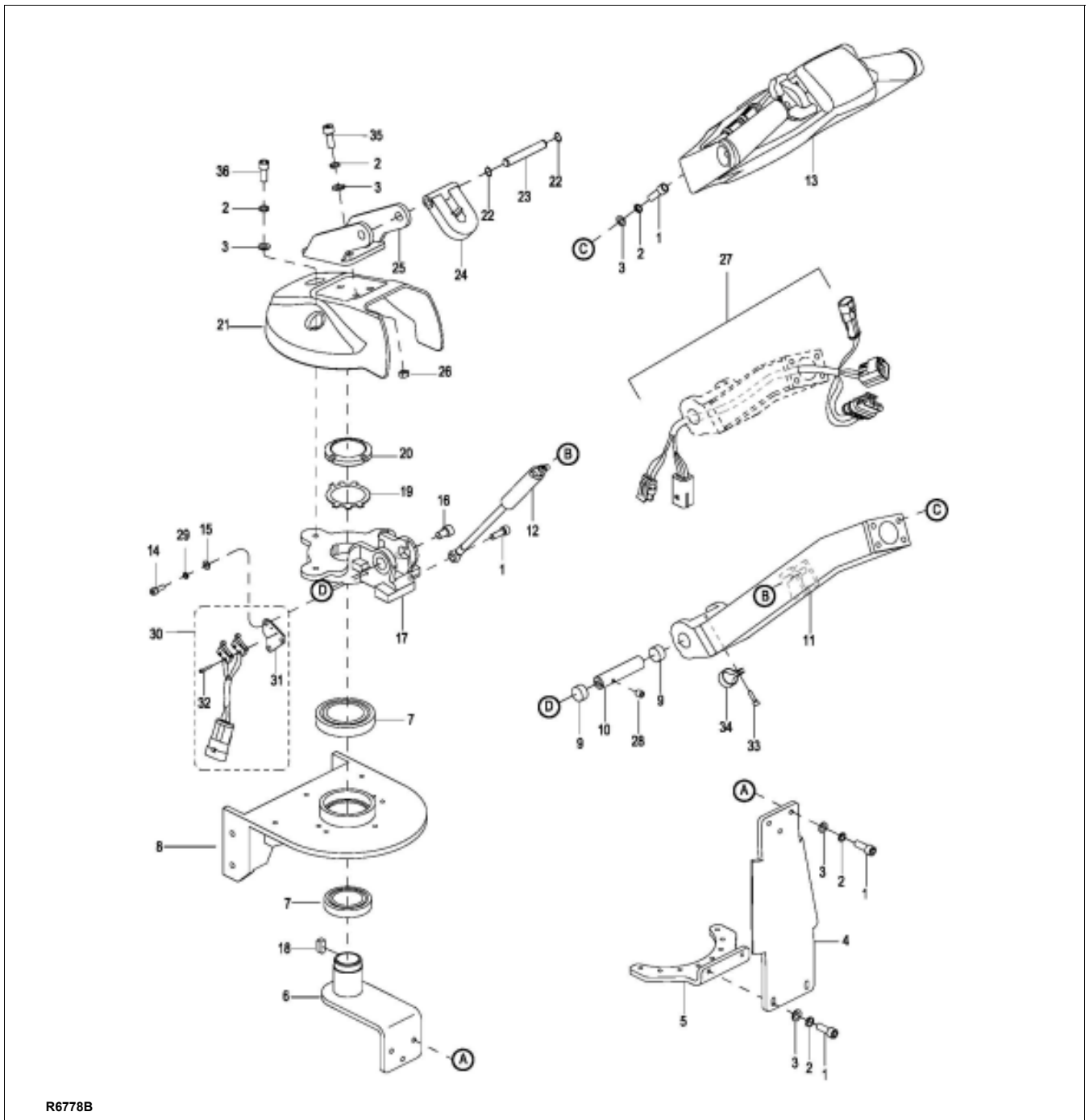

R6778B

Figure 5-1 Steering Arm

5-1.2. Cover Installation.

1. Hold cover (4, [Figure 5-2](#)) in place and connect harness (27, [Figure 5-1](#)) to switch harness (21, [Figure 5-2](#)).
2. Position cover (4, [Figure 5-2](#)) on control head and secure with two screws (5) and two screws (6).
3. Reconnect the batteries and turn on the key switch (13, [Figure 12-13](#)).

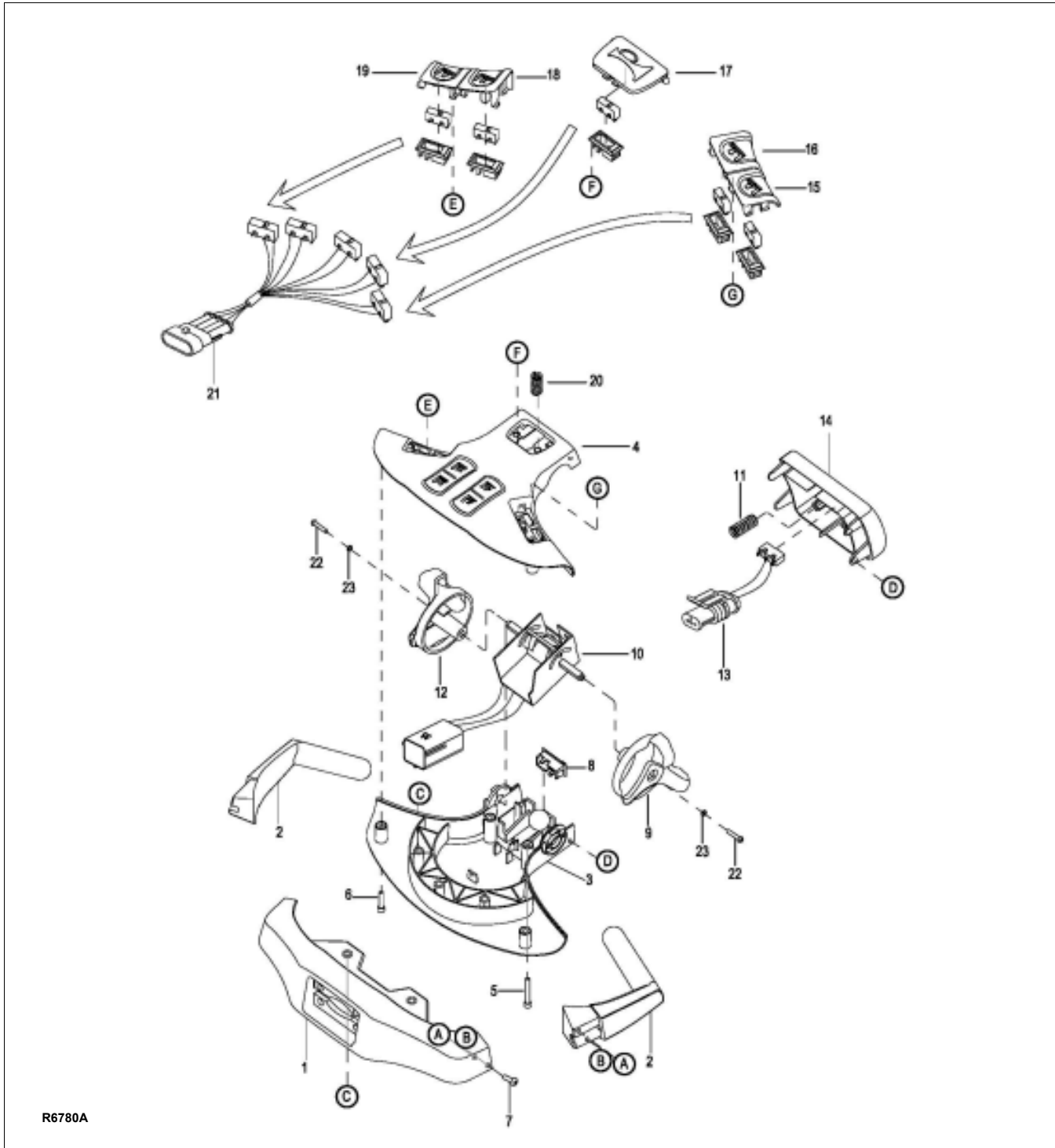

Figure 5-2 Control Head

5-1.3. Control Head Removal

1. Turn off the key switch (13, [Figure 12-13](#)) and disconnect the batteries.
2. Remove the cap assembly as described in paragraph [5-1.1](#).
3. Disconnect harness (27, [Figure 5-1](#)) from switch (13, [Figure 5-2](#)) and potentiometer (10).

WARNING: When removing the control head in the following steps, be sure to hold it in place until the control harness is disconnected.

4. Remove four screws (1), four lock washers (2), four flat washers (3) and control head (13).

5-1.4. Control Head Installation

1. Secure control head with four screws (1), four lock washers (2) and four flat washers (3).
2. Connect harness (27, [Figure 5-1](#)) to switch (13, [Figure 5-2](#)) and potentiometer (10).
3. Install the cap assembly as described in paragraph [5-1.2](#).
4. Reconnect the batteries and turn on the key switch (13, [Figure 12-13](#)).

5-1.5. Belly-Button Switch Replacement.

1. Remove the cover as described in paragraph [5-1.1](#).
2. Disconnect harness (27, [Figure 5-1](#)) from switch (13, [Figure 5-2](#)).
3. Remove switch (13) from bracket (8) by releasing the two tabs of the bracket and pulling up on the switch.
4. Press the new switch (13) in bracket (8) until it locks in place.
5. Connect (27, [Figure 5-1](#)) to switch (13, [Figure 5-2](#)).
6. Install the cover as described in paragraph [5-1.2](#).

5-1.6. Horn, Lift and Lower Switch Replacement.

1. Remove the cover as described in paragraph [5-1.1](#).
2. Before removing the five switches of switch harness (21, [Figure 5-2](#)) from their brackets (8) tag them with their functional position.
3. Remove horn, lift and lower switches from their brackets (8) by releasing the two tabs of the bracket and pulling up on the switch.
4. Replace switch harness as an assembly.

5. Press the new switches (13) into their brackets (8) until they lock in place. Refer to the tags added in the remove process.
6. Install the cover as described in paragraph [5-1.2](#).

5-1.7. Speed Potentiometer Replacement.

1. Remove the cover as described in paragraph [5-1.1](#).
2. Disconnect harness (27, [Figure 5-1](#)) from potentiometer (10, [Figure 5-2](#)).
3. Remove screw (22), lock washer (23) and control knob (9) from potentiometer (10).
4. Remove screw (22), lock washer (23) and control knob (12) from other side of potentiometer (10).
5. Remove potentiometer (10) from cover (3).
6. Position new potentiometer (10) in cover (3).
7. Install control knob (9) on potentiometer (10) and secure with screw.
8. Install control knob (12) on the other side of potentiometer (10) and secure with screw.
9. Connect harness (27, [Figure 5-1](#)) to potentiometer (10, [Figure 5-2](#)).
10. Install the cover as described in paragraph [5-1.2](#).

5-2. STEERING ARM

5-2.1. Return Spring Replacement.

The steering arm gas return spring (12, [Figure 5-1](#)) is replaced while the steering arm (11) is in the upright position.

1. Turn off the key switch (13, [Figure 12-13](#)) and disconnect the batteries.
2. Remove three screws (36 [Figure 5-1](#)), three lock washers (2), three flat washers (3) and cover (21).
3. Secure the steering arm (11) in the upright position.

CAUTION: Use caution when removing the mounting screw and the gas return spring. The spring is under tension.

4. Remove screw (1) and free the gas return spring (12) from bracket (17).
5. Pull downward on the gas return spring (12) to free it from its seat inside steering arm (11).
6. Position the new gas return spring (12) inside the steering arm being sure it fully engages its seat.
7. Position the opposite end of the gas return spring (12) on bracket (17) and install screw (1).

8. Install cover (21) and secure with three screws (36), three lock washers (2) and three flat washers (3).
9. Reconnect the batteries and turn on the key switch (13, [Figure 12-13](#)).

5-2.2. Steering Arm Removal.

1. Turn off the key switch (13, [Figure 12-13](#)) and disconnect the batteries.
2. Remove the compartment covers as described in paragraph 5-3.
3. Disconnect harness (27) from harness (1, [Figure 12-15](#)).
4. Disconnect brake switch (30, [Figure 5-1](#)) from harness (1, [Figure 12-15](#)).
5. Attach a hoist to steering arm (11, [Figure 5-1](#)).
6. Remove four screws (7, [Figure 12-1](#)), lock washers (8), flat washers (9) and nuts (3) securing the steering arm assembly to the frame.
7. Remove eight screws (4), lock washers (5) and flat washers (6) securing the steering arm assembly to the transmission.
8. Remove the steering arm assembly.

5-2.3. Steering Arm Installation.

1. Position steering arm assembly on the transmission and secure with eight screws (4, [Figure 12-1](#)), lock washers (5) and flat washers (6).
2. Secure the steering arm assembly to the frame with four screws (7), lock washers (8), flat washers (9) and nuts (3).

3. Reconnect harness (27, [Figure 5-1](#)) to harness (1, [Figure 12-15](#)).
4. Reconnect brake switch (30, [Figure 5-1](#)) from harness (1, [Figure 12-15](#)).
5. Install the compartment covers as described in paragraph 5-3.
6. Reconnect the batteries and turn on the key switch (13, [Figure 12-13](#)).

5-3. COMPARTMENT COVERS

5-3.1. Removal.

1. Turn off the key switch (13, [Figure 12-13](#)) and disconnect the batteries.
2. Remove mat (1, [Figure 12-7](#)).
3. Loosen screws (16, [Figure 12-13](#)) to provide clearance between cover (11) and cover (1, [Figure 12-1](#)).
4. Remove two screws (2) and pry cover (1) away from the frame.

5-3.2. Installation.

1. Position cover (1, [Figure 12-1](#)) on the frame and tap it forward. Secure with two screws (2). Do not over tighten the screws.
2. Reinstall mat (1, [Figure 12-7](#)).
3. Reconnect the batteries and turn on the key switch (13, [Figure 12-13](#)).

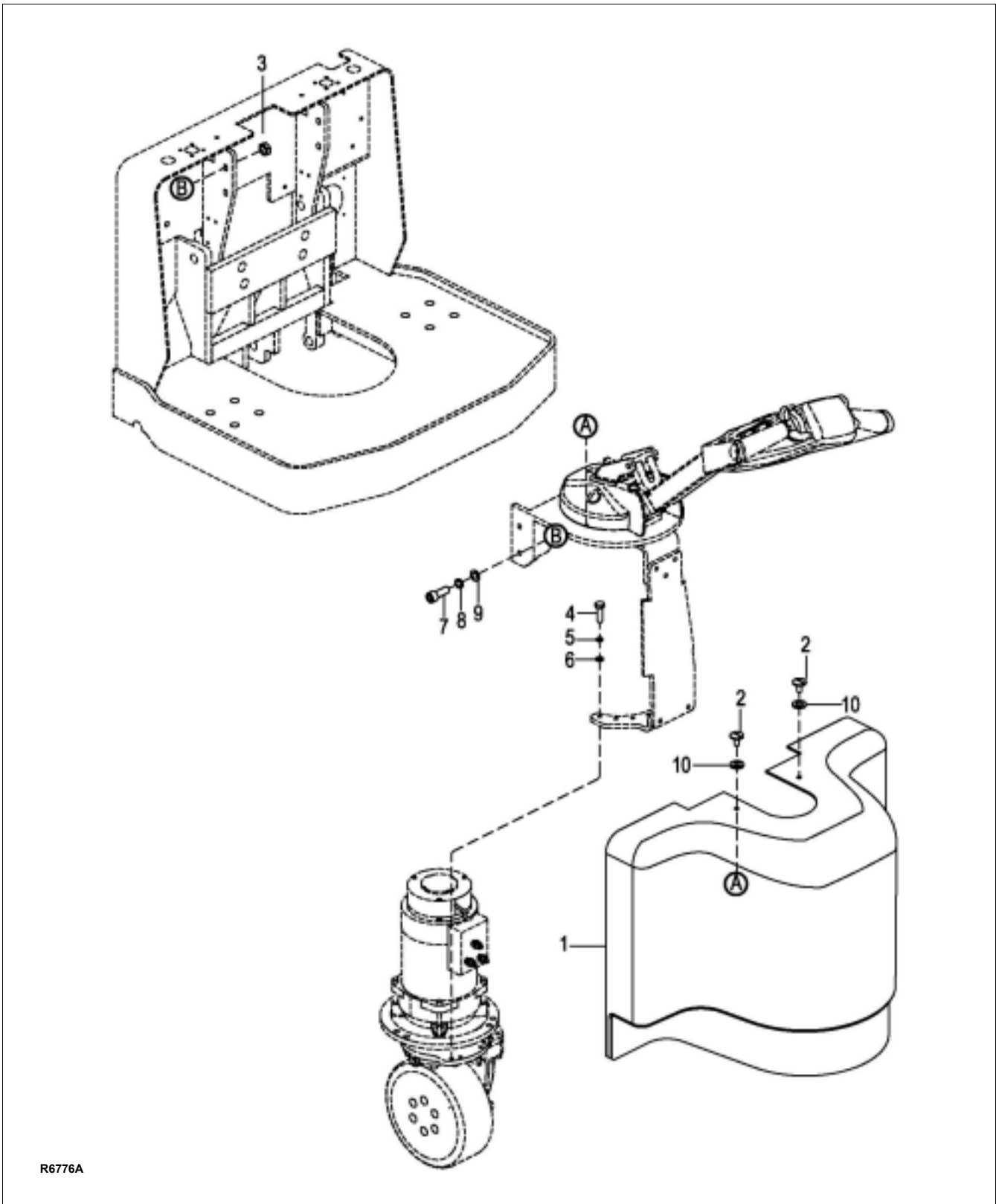

R6776A

Figure 5-3 Steering System

NOTES

SECTION 6 BRAKE SERVICING

6-1. BRAKE.

The brake system consists of a drive motor mounted brake. This brake is spring applied and electrically released.

6-1.1. Air Gap Adjustment.

The "air gap" is the distance between the magnet body and the rotor plate with the brake applied. As the brake pads and rotor wear normally, the air gap will increase and should be readjusted when it measures more than 0.25 mm.

NOTE: If the air gap measures more than 0.25 mm, the brake may not release properly. Air gap adjustment can be performed as long as the brake pads and rotor function properly or until the adjustable spacer threads are fully engaged (adjustment limit reached).

1. Block load wheels.
2. Remove the compartment covers as described in paragraph 5-3.
3. Using low pressure air, remove any dirt between armatures and magnet body.
4. Using standard feeler gauges, check the gap between the magnet body and the rotor plate. The gap should be 0.25 mm.
5. If necessary, refer to [Figure 6-1](#) and adjust the gap as follows:
 - a. Loosen the three mounting screws by half a turn.
 - f. The threaded air gap adjusting nuts can then be screwed into Magnet Body by turning counterclockwise.
 - g. Turn the three mounting screws clockwise until the gap measures 0.012" (0.25 mm).
 - h. The threaded air gap adjusting nuts are then screwed clockwise until they bottom.
 - i. Finally tighten the three mounting screws to 52 in-lb (6 Nm).
 - j. Recheck the gap.

11. Remove load wheel blocks and check operation.
12. Install the compartment covers as described in paragraph 5-3.

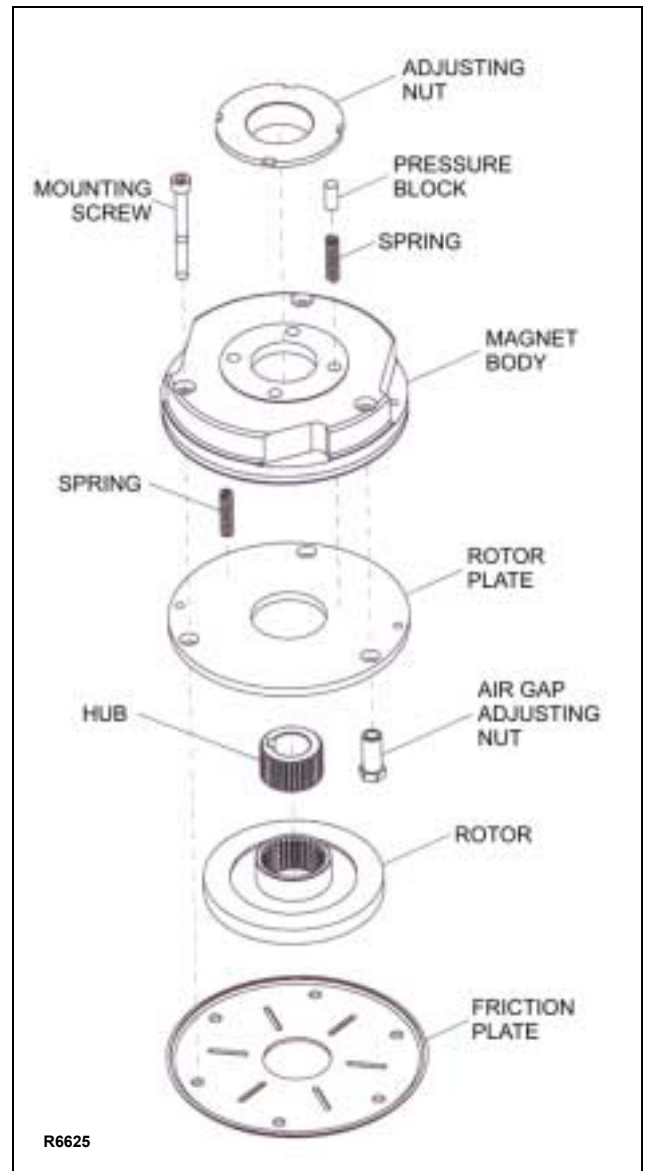

Figure 6-1 Brake Assembly

6-1.2. Stopping Distance Adjustment.

The stopping distance of the truck should require minimal adjustment. However, this distance should be checked with each planned maintenance.

Using an unloaded truck, run truck to its top speed on an even dry concrete surface. Move control handle into the lower braking position. Measure length of braking path from the actuation point of the brakes until the truck has stopped. The actual length of the braking path should be between approximately 1.5 - 2.5 ft (0.5-0.7 m).

To adjust stopping distance, proceed as follows:

1. Block load wheels.
2. Remove the compartment covers as described in paragraph 5-3.
3. Rotate the adjusting nut (Figure 6-1) clockwise to SHORTEN the stopping distance or counterclockwise to LENGTHEN the stopping distance.
4. Remove load wheel blocks and check operation.

5. Install the compartment covers as described in paragraph 5-3.

6-1.3. Brake Assembly Replacement

1. Block load wheels.
2. Remove the compartment covers as described in paragraph 5-3.
3. Disconnect electric brake (49, Figure 12-6) from harness (1, Figure 12-15).
4. Remove the three mounting screws (Figure 6-1) and the brake.
5. Place the new brake into position and secure with the three mounting screws.
6. Finally tighten the three mounting screws to 52 in-lb (6 Nm).
7. Reconnect electric brake (49, Figure 12-6) to harness (1, Figure 12-15).
8. Remove load wheel blocks and check operation.
9. Install the compartment covers as described in paragraph 5-3.

SECTION 7 TRANSMISSION, DRIVE WHEEL, LOAD WHEEL

7-1. Drive Wheel.

1. Turn off the key switch (13, [Figure 12-13](#)) and disconnect the batteries.
2. Remove the compartment covers as described in paragraph 5-3.
3. Loosen but do not remove the six screws (35, [Figure 7-1](#)).
4. Jack up the truck so the drive wheel is off the ground; then securely block the truck to prevent movement.
5. Remove the six screws (35) and drive wheel (47) from the transmission.
6. Install new drive wheel in reverse order of removal.
7. Install the compartment covers as described in paragraph 5-3.
8. Reconnect the batteries and turn on the keyswitch (13, [Figure 12-13](#)).

7-2. Transmission.

1. Turn off the key switch (13, [Figure 12-13](#)) and disconnect the batteries.
2. Block the load wheels securely.
3. Remove the compartment covers as described in paragraph 5-3.
4. Remove the brake (49, [Figure 7-1](#)) as described in paragraph 6-1.3.
5. Remove the drive motor (48, [Figure 7-1](#)) as described in paragraph 10-4.
6. Using a suitable means, raise the truck frame enough to provide clearance for removal of the transmission/motor/brake.
7. Support the transmission and remove six screws (7, [Figure 7-2](#)), six lock washers (8) and six flat washers (9).
8. Slowly lower the transmission out the bottom of the frame.
9. Install new transmission by reversing the steps above.

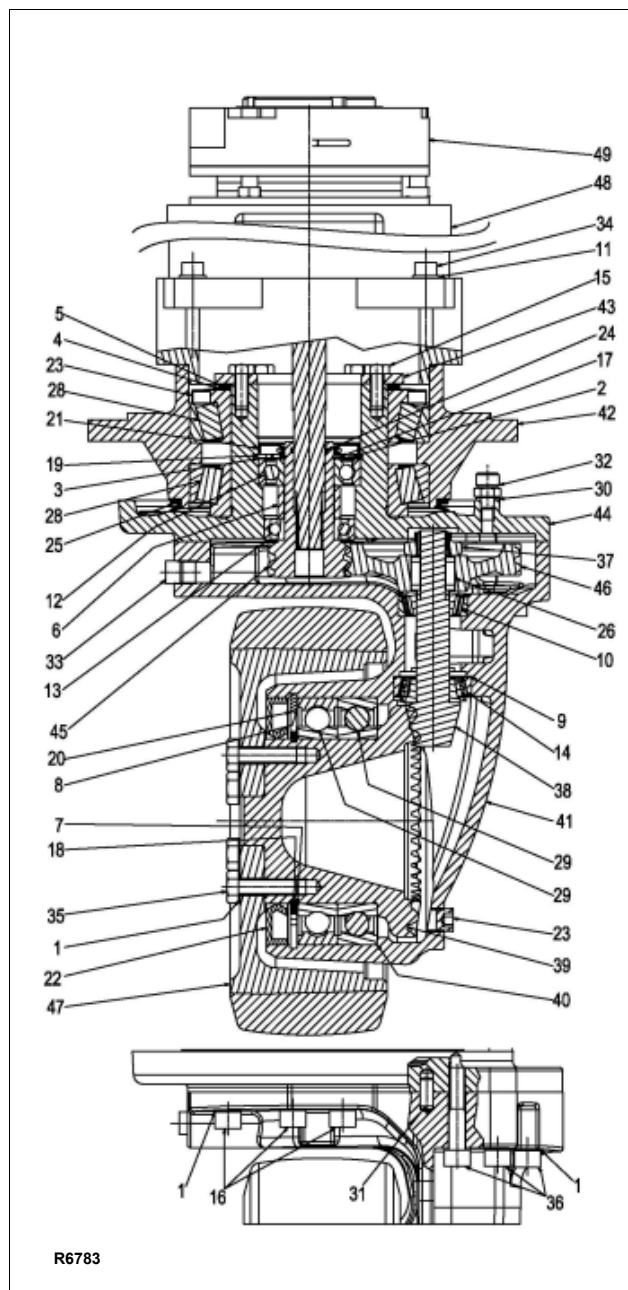
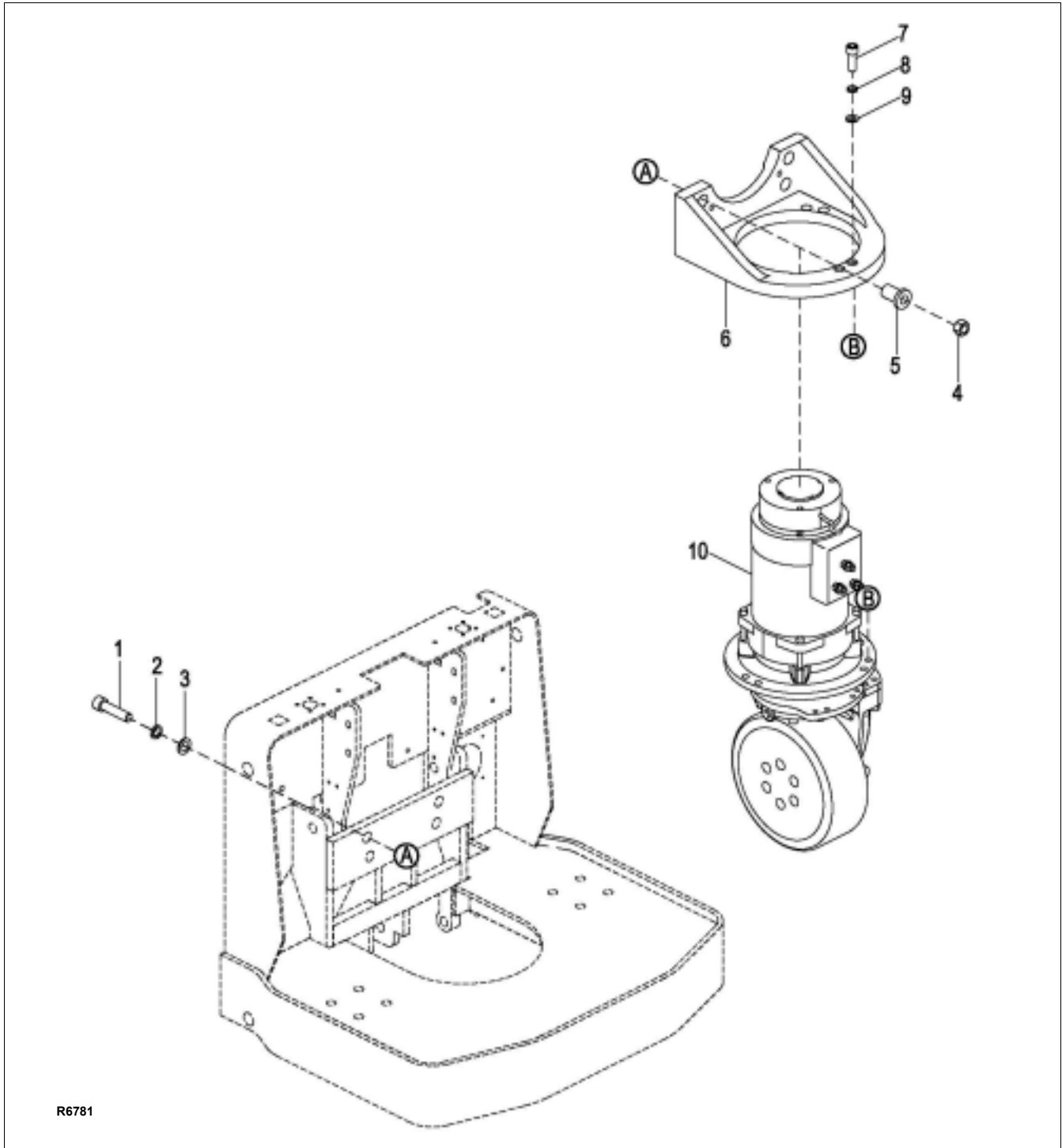

Figure 7-1 Transmission, Motor, Brake Assembly



R6781

Figure 7-2 Drive System

7-3. Load Wheel.

7-3.1. Removal

1. Raise forks.
2. Turn off the key switch (13, [Figure 12-13](#)) and disconnect the batteries.
3. Block the drive wheel to prevent the truck from rolling.
4. Jack up the forks to raise the load wheels off the floor. Securely block the forks in the raised position by positioning supports under both fork tips.

NOTE: When shaft (20, [Figure 12-8](#)) is removed, load wheel assembly (19) will drop free.

5. Remove pin (6) securing shaft (20) and remove shaft (20) and load wheel assembly (19).

NOTE: Inspect the load wheel assembly. If the load wheel is worn within 1/8" of the metal sleeve, or is cracked or damaged, replace the entire load wheel and bearing assembly. Blue Giant recommends that both load wheel assemblies be replaced at the same time. This ensures level and safe operation of the lift truck.

7-3.2. Repair

6. Remove washers (23, [Figure 12-8](#)), bearings (21) and washers (22) from wheels (19).
7. Inspect bearings (21) and replace if necessary.
8. Reassemble washers (23), bearings (21) and washers (22) in wheels (19).

7-3.3. Load Wheel Installation

1. Position load wheel assembly (19, [Figure 12-8](#)) in wheel bracket (17).
2. Install shaft (20) and secure with pin (6).
3. Remove blocking from under the truck.
4. Lower the forks.
5. Reconnect the batteries and turn on the keyswitch (13, [Figure 12-13](#)).

7-4. CASTERS

Casters provide for additional stability. Installation of the casters is shown in [Figure 12-7](#) and repair parts as shown in [Figure 12-9](#).

NOTES

SECTION 8 ELEVATION SYSTEM SERVICING

8-1. LIFT LINKAGE

8-1.1. Removal

1. Lift complete truck to height sufficient to permit access to lift linkage under forks. Provide blocking under frame (3, [Figure 8-1](#)), the rear of fork frame (15) and at tips of the forks.
2. Turn off the key switch (13, [Figure 12-13](#)) and disconnect the batteries.
3. Remove pin (6, [Figure 8-2](#)) and remove shaft (18). Lower the front of link (9) to the floor.
4. Remove pin (6) and remove shaft (5). Free the front of link (8) from the fork frame.
5. Remove two pins (3) and remove shaft (2). Free the rear of link (8) from the main frame.
6. Remove the link assembly from under the fork.

8-1.2. Repair

1. Remove pin (3, [Figure 8-2](#)) and shaft (13). Free bracket (17) from bar end (12).
2. Inspect bushings (4) in bar end (12). If necessary, remove and replace the bushings.

3. Remove pin (3) and shaft (14). Free roller (16) from bracket (17).
4. Inspect bushings (15) in roller (16). If necessary, remove and replace the bushings.
5. Remove pin (3) and shaft (7). Free bar (9) from link (8).
6. Inspect bushings (4) in link (8). If necessary, remove and replace the bushings.
7. Reassembly by reversing the steps above.

8-1.3. Installation

1. Position the link assembly from under the fork.
2. Position the rear of link (8, [Figure 8-2](#)) in the main frame and install shaft (2) and two pins (3).
3. Position the front of link (8) in fork frame. and install shaft (5) and pin (6).
4. Position link (9) in the fork and install shaft (18) and pin (6).
5. Remove blocking and lower the truck to the ground.
6. Reconnect the batteries and turn on key switch (13, [Figure 12-13](#)) .

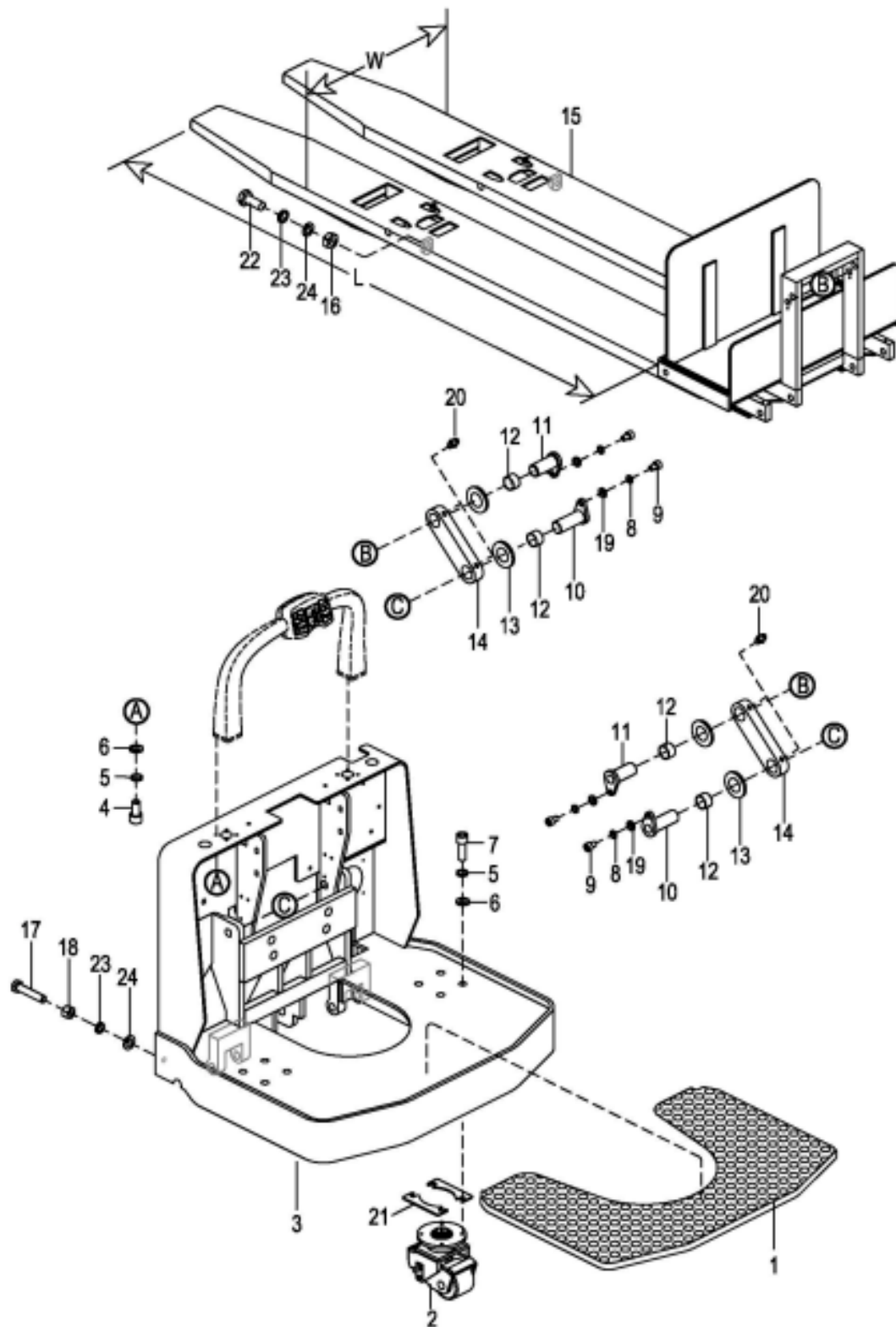

R6786A

Figure 8-1 Frame

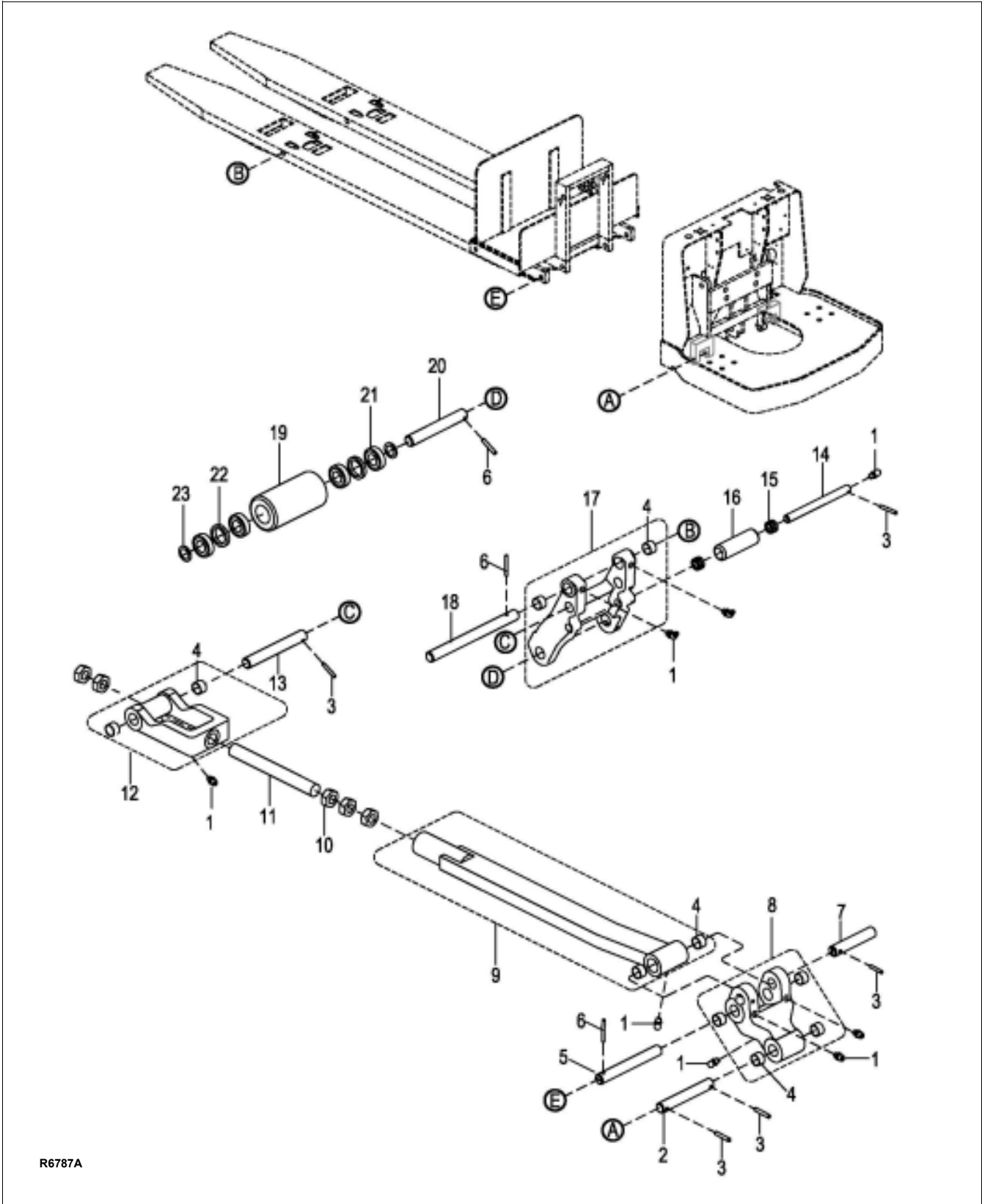

R6787A

Figure 8-2 Lift Linkage

NOTES

SECTION 9

HYDRAULIC SYSTEM SERVICING

9-1. LINES AND FITTINGS

WARNING: When forks are raised, pressure exists in the hydraulic system lines and fittings. To ensure release of pressure, forks must be fully lowered and the batteries disconnected before performing any maintenance on the hydraulic system.

NOTE: Leaking hydraulic fittings may be remedied by simply tightening fittings. If this does not remedy the leak, the fittings or line must be replaced.

1. Lower forks fully.
2. Turn off the key switch (13, [Figure 12-13](#)) and disconnect the batteries.
3. Remove the compartment covers as described in paragraph [5-3](#).

CAUTION: Hydraulic oil can damage parts. Wipe off any oil immediately. Provide a container under the line or fitting before disconnecting.

4. Refer to [Figure 9-1](#) and remove leaking line or fitting and replace it with a new line or fitting.
5. Check level of hydraulic oil. If required, add hydraulic oil to bring to 1 inch below opening. Use hydraulic oil listed in [Table 3-2](#).
6. Reconnect the batteries and turn on the keyswitch (13, [Figure 12-13](#)).
7. Operate the lift and lower buttons to refill the cylinder and lines with hydraulic oil.
8. Check level of hydraulic oil. If required, add hydraulic oil to bring to 1 inch below opening. Use hydraulic oil listed in [Table 3-2](#).

9. Install the compartment covers as described in paragraph [5-3](#).

9-2. HYDRAULIC PUMP, MOTOR, AND RESERVOIR ASSY

The hydraulic pump/motor assembly can be disassembled and repaired. However, a defective pump, valve or motor requires replacement of that component.

WARNING: When forks are raised, pressure exists in the hydraulic system lines and fittings. To ensure release of pressure, forks must be fully lowered and the batteries disconnected before performing any maintenance on the hydraulic system.

9-2.1. Removal

1. Lower forks fully.
2. Turn off the key switch (13, [Figure 12-13](#)) and disconnect the batteries.
3. Remove the compartment covers as described in paragraph [5-3](#).
4. Tag and disconnect electrical leads from pump/motor assembly (6, [Figure 9-2](#)) and solenoid (5).

NOTE: The reservoir and hose will be filled with hydraulic oil. Place a container under the pump assembly to catch any hydraulic oil.

5. Disconnect hose (3, [Figure 9-1](#)) from pump/motor assembly (4).
6. While supporting the pump/motor assembly (4), remove two screws (5), two lock washers (6) and two flat washers (7).
7. Remove the pump/motor assembly (4).

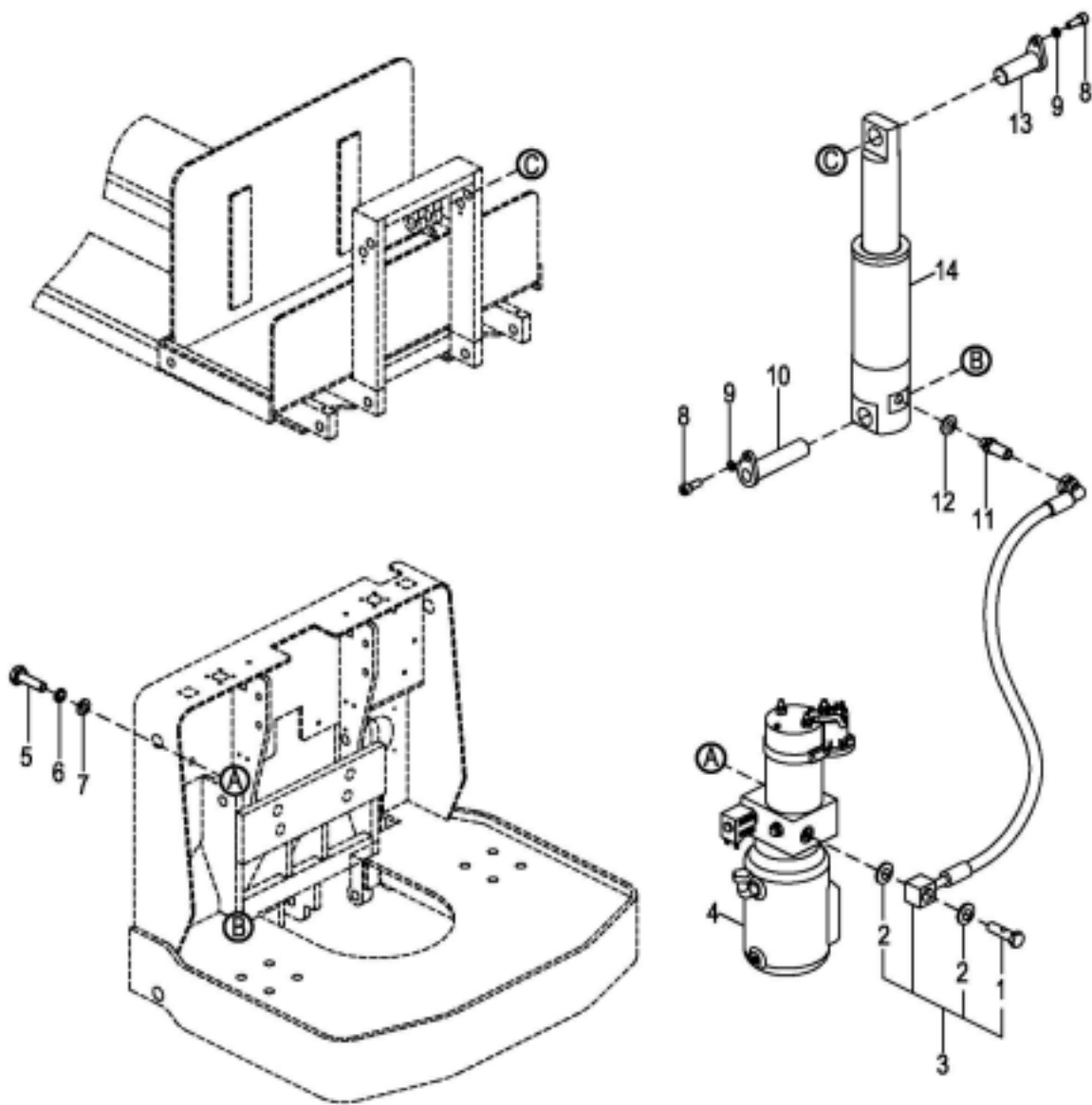

R6789

Figure 9-1 Hydraulic System

9-2.2. Disassembly and Reassembly

1. Remove the hydraulic pump/motor assembly as described in paragraph 9-2.1.
2. Refer to Figure 9-2 for disassembly and reassembly.

9-2.3. Installation

1. While supporting the pump/motor assembly (4, Figure 9-1), install two screws (5), two lock washers (6) and two flat washers (7).
2. Reconnect hose (3) to pump/motor assembly (4).
3. Connect electrical leads to motor (6, Figure 9-2) and solenoid (5).
4. Fill the hydraulic reservoir to 1 inch below opening. Use hydraulic oil listed in Table 3-2.
5. Reconnect the batteries and turn on the keyswitch (13, Figure 12-13).
6. Operate the lift and lower buttons to refill the cylinder and lines with hydraulic oil.
7. Check level of hydraulic oil. If required, add hydraulic oil to bring to 1 inch below opening. Use hydraulic oil listed in Table 3-2.
8. Install the compartment covers as described in paragraph 5-3.

9-2.4. Lift Cylinder

9-2.4.1. Removal

1. Lower forks fully.
2. Turn off the key switch (13, Figure 12-13) and disconnect the batteries.
3. Remove the compartment covers as described in paragraph 5-3.
4. Ensure that hydraulic pressure has been relieved from the lift circuit.
5. Disconnect hose (3, Figure 9-1) from cylinder (11).
6. Remove connector (11) and seal (12) from cylinder (14).
7. Remove screw (8, Figure 9-1), lock washer (9) and shaft (13) securing the top of cylinder (14).

WARNING: Frame is heavy. Use care while securing and lifting in order to prevent injury.

8. With suitable hoist, carefully raise frame (15, Figure 12-7) slightly to relieve pressure from the cylinder mounts.
9. Remove screw (8, Figure 9-1), lock washer (9) and shaft (10) securing the bottom of cylinder (14) and remove the cylinder.

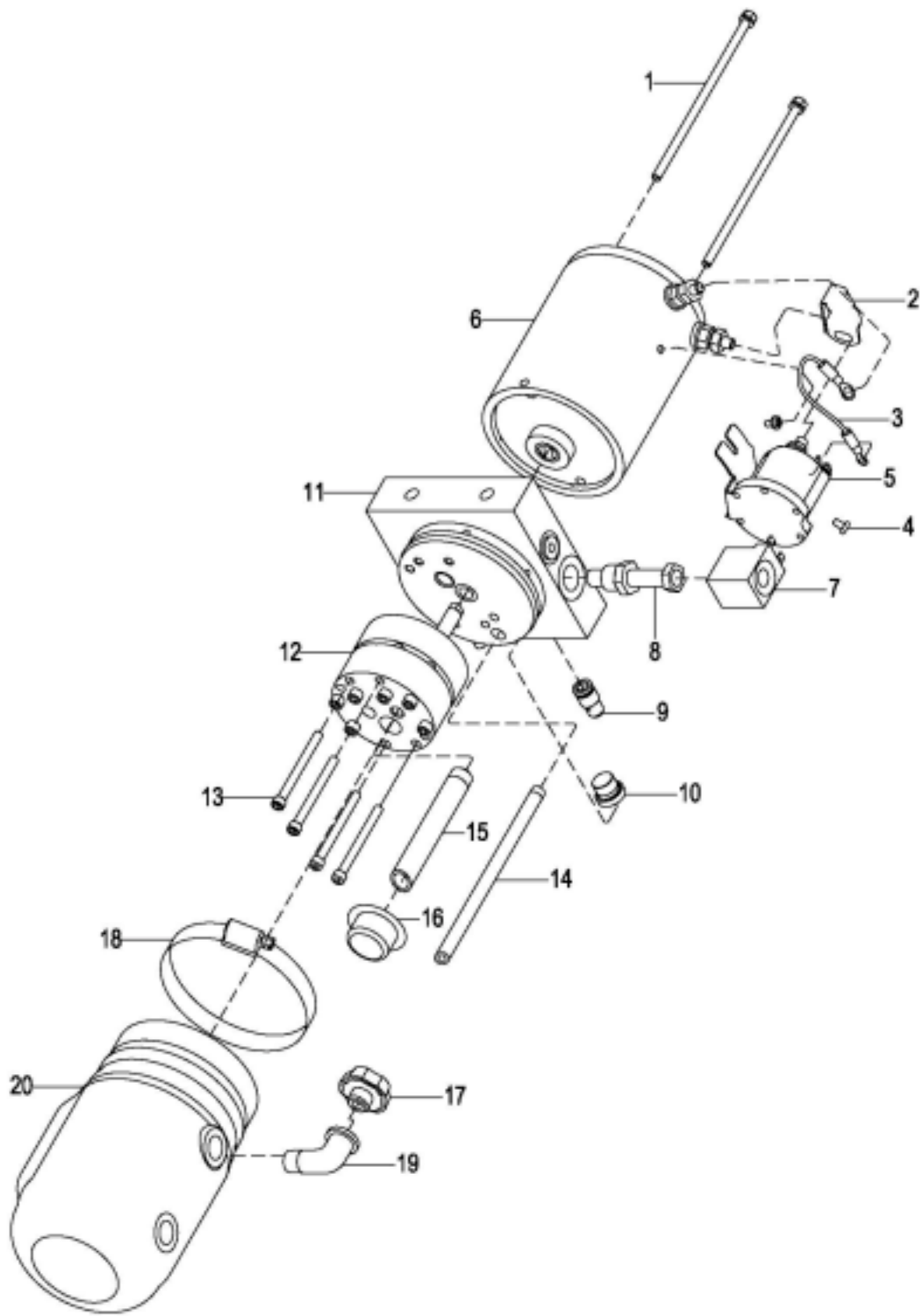

R6790

Figure 9-2 Pump & Motor Assy

9-2.4.2.Repair

1. Secure the lift cylinder in a vise, clamping lightly at the base of the cylinder.
2. Remove gland nut (2, [Figure 9-3](#)) from cylinder tube (7).
3. Remove wiper ring (1) and O-ring (3) from gland nut (2).
4. Withdraw the cylinder rod (4) from the cylinder.

NOTE: If the cylinder tube (7) or piston rod (4) are damaged, the entire lift cylinder must be replaced.

5. Replace seal ring (6) and guide ring (5) from piston rod (4).
6. Coat all parts with hydraulic oil ([Table 3-2](#)).
7. Install guide ring (5) and new seal ring (6) on piston rod (4).
8. Insert piston rod (4), with attached parts, into cylinder tube (7).
9. Install new wiper ring (1) and new O-ring (3) on gland nut (2).
10. Install gland nut (2) on cylinder tube (7).

9-2.4.3.Installation

1. Position the cylinder in the frame and secure the bottom of the cylinder with shaft (10, [Figure 9-1](#)), screw (8) and lock washer (9).
2. Secure top of cylinder with shaft (13), screw (8) and lock washer (9).
3. Using a suitable hoist, carefully lower frame (15, [Figure 12-7](#)).
4. Reconnect the hose (3, [Figure 9-1](#)) to cylinder (14).
5. Fill the hydraulic reservoir to 1 inch below opening. Use hydraulic oil listed in [Table 3-2](#).
6. Reconnect the batteries and turn on the keyswitch (13, [Figure 12-13](#)).

7. Operate the lift and lower buttons to refill the cylinder and lines with hydraulic oil.
8. Check level of hydraulic oil. If required, add hydraulic oil to bring to 1 inch below opening. Use hydraulic oil listed in [Table 3-2](#).
9. Install the compartment covers as described in paragraph [5-3](#).

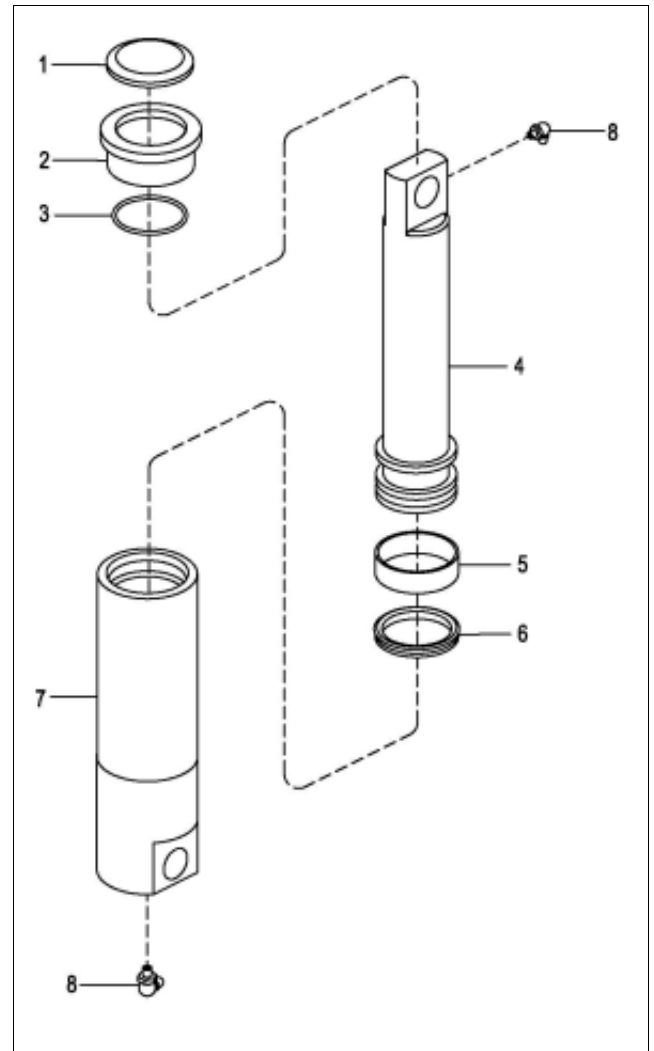

Figure 9-3 Lift Cylinder

NOTES

SECTION 10 ELECTRICAL COMPONENTS

10-1.ELECTRICAL CONTROL PANEL

10-1.1.Maintenance

NOTE: Erratic operation of the truck may be caused by defective controller components. Before removing the electrical panel, perform troubleshooting procedures per [SECTION 4](#), to determine corrective action to be taken.

There are no user-serviceable parts inside the controller. No attempt should be made to open the controller. Opening the controller may damage it and will void the warranty.

The controller is programmed at the factory specifically for the truck model on which it is equipped. It is important to replace the controller with the correct pre-programmed unit to assure proper performance settings intended for that particular truck. See [Figure 12-14](#) for the preprogrammed controller number.

It is recommended that the controller exterior be cleaned periodically, and if a Zapi Can Console kit and laptop computer are available, this periodic cleaning provides a good opportunity to check the controller's diagnostic history file. It is also recommended that the controller's fault detection circuitry be checked whenever the vehicle is serviced.

10-1.2. Cleaning

1. Turn off the key switch (13, [Figure 10-2](#)) and disconnect the batteries.
2. Remove the compartment cover as described in [paragraph 5-3](#).
3. Remove any dirt or corrosion from the bus bar area. The controller should be wiped clean with a moist rag. Allow it to dry before reconnecting the battery.
4. Make sure the connections to the buss bars are tight. Use two well insulated wrenches for this task in order to avoid steering the buss bars.

10-1.3. Panel Removal.

1. Turn off the key switch (13, [Figure 10-2](#)) and disconnect the batteries.

2. Remove the compartment covers as described in [paragraph 5-3](#).
3. Tag and disconnect all electrical cables which connect to the control panel (15).
4. Remove four screws (1), four lock washers (2), four flat washers (3), and control panel (15).

10-1.4. Panel Disassembly.

Refer to [Figure 10-3](#) for location and identity of the major replacement components mounted on the panel and remove defective parts.

NOTE: Contactor (15) is not repairable and must be replaced if defective.

10-1.5. Panel Installation.

1. Install the control panel (15, [Figure 10-2](#)) and secure with four screws (1), four lock washers (2), four flat washers (3).
2. Refer to [Figure 12-15](#) thru [Figure 12-16](#) and connect all electrical cables to the control panel as noted during removal.
3. If controller (1, [Figure 10-3](#)) was replaced, the Vacc will need to be programmed as follows:
 - a. Connect the Zapi Can and start the Laptop computer as described in [paragraph 4-2.1](#).
 - d. On the ZAPI PC Can Console screen, click on Program VACC. (See [Figure 10-1](#))



Figure 10-1 Screen 11

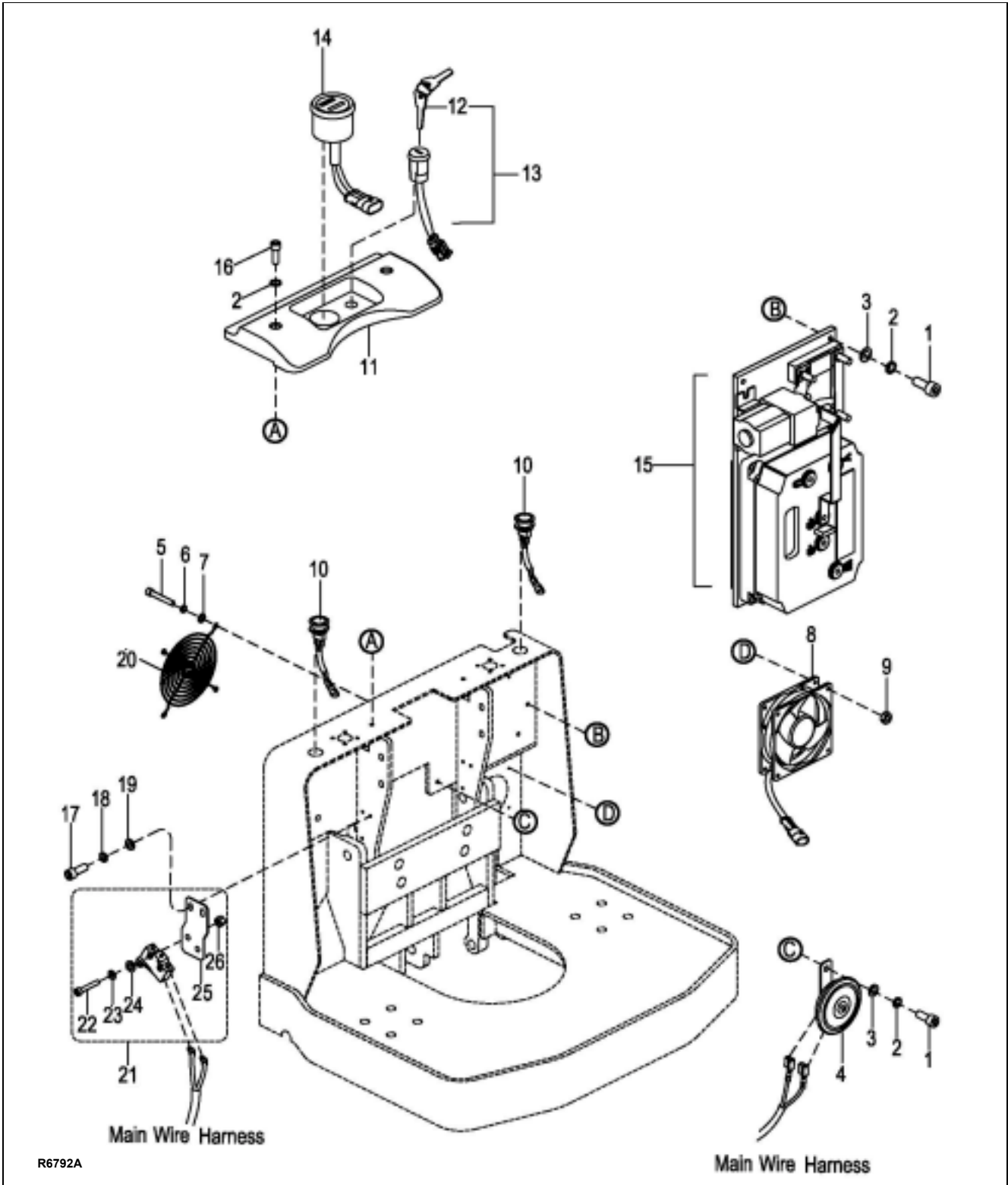
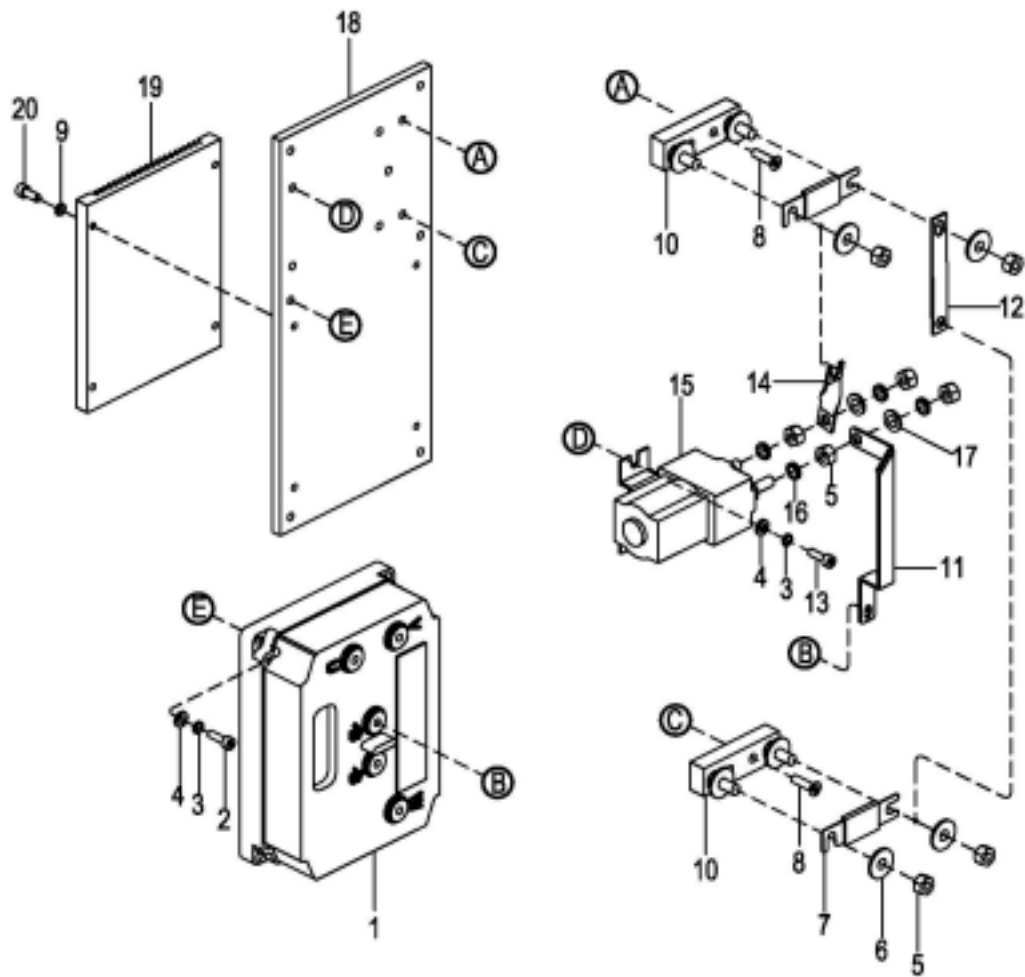

Figure 10-2 Electrical System



R6794A

Figure 10-3 Electrical Panel

- e. Click and hold the **Acquire** button (Figure 10-4). Move the control arm to the travel position and rotate the speed control (See Figure 10-5) located on each side of the control head to the forward position. The **FORWARD Maximum** voltage will change to 2.4 V.
 - f. Click and hold the **Acquire** button (Figure 10-4). Move the control arm to the travel position and rotate the speed control (See Figure 10-5) located on each side of the control head to the reverse position. The **BACKWARD Maximum** voltage will change to 2.4 V.
 - g. Release the **Acquire** button (Figure 10-4) and then press the **Save** button to store these settings.
8. Install the compartment covers as described in paragraph 5-3.
 9. Reconnect the batteries and turn on the keyswitch (13, Figure 10-2).



Figure 10-4 Screen 11

10-2.HORN REPLACEMENT

1. Turn off the key switch (13, Figure 10-2) and disconnect the batteries.
2. Remove the compartment covers as described in paragraph 5-3.
3. Tag and disconnect all electrical connections from horn (4).
4. Remove screw (1), lock washer (2), flat washer (3), and horn (4).
5. Install horn (4) and secure with (1), lock washer (2), flat washer (3).
6. Install the compartment covers as described in paragraph 5-3.
7. Reconnect the batteries and turn on the keyswitch (13).

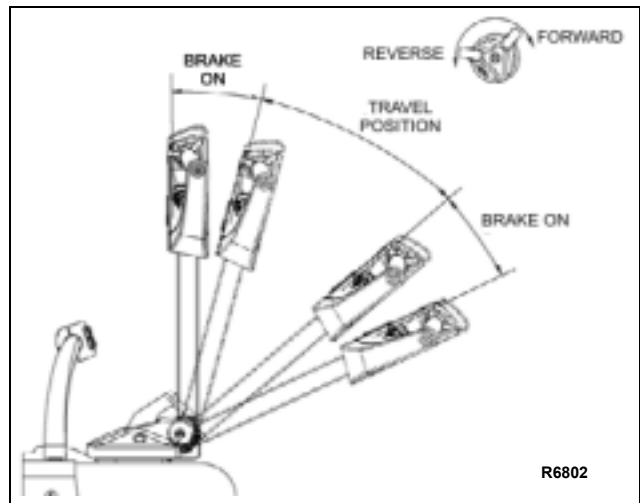

Figure 10-5 Brake Actuation

10-3.PUMP MOTOR.

The pump motor is replaceable but not repairable. Refer to paragraph 9-2.

10-4.DRIVE MOTOR.

The drive motor exposed surfaces should be cleaned at least once a month to assure proper cooling of motor. Use an air hose to blow dust off of motor surfaces.

10-4.1. Motor Removal

1. Remove the brake as described in paragraph 6-1.3.
2. Note routing of cables to ensure proper installation.
3. Tag the cables connected to the drive motor; then disconnect these cables from the drive motor.
4. Remove the four screws (34, Figure 10-6) and lift motor (48) from the transmission.

10-4.2. Motor Installation

5. Install drive motor (48, Figure 10-6) on the transmission (12). Make sure to align the gears.
6. Reinstall four screws (34).
7. Position cables as noted in removal and reconnect the cables to the drive motor.
8. Reinstall the brake as described in paragraph 6-1.3.

10-5.LIFT LIMIT SWITCH

10-5.1.Replacement

1. Disconnect wiring from the lift limit switch (21, Figure 10-2).
2. Remove the two screws (17), two lock washers (18), flat washers (19) and switch (21).
3. Remove the two nuts (26), two screws (22), two lock washers (23), flat washers (24), and mounting plate (25) from the switch.
4. Position the new switch on mounting plate (25) and secure with two screws (22), two lock washers (23), flat washers (24) and two nuts (26).
5. Position bracket (25) on the frame and secure with two screws (17), two lock washers (18) and two flat washers (19).
6. Adjust the switch as described in paragraph 10-5.2.

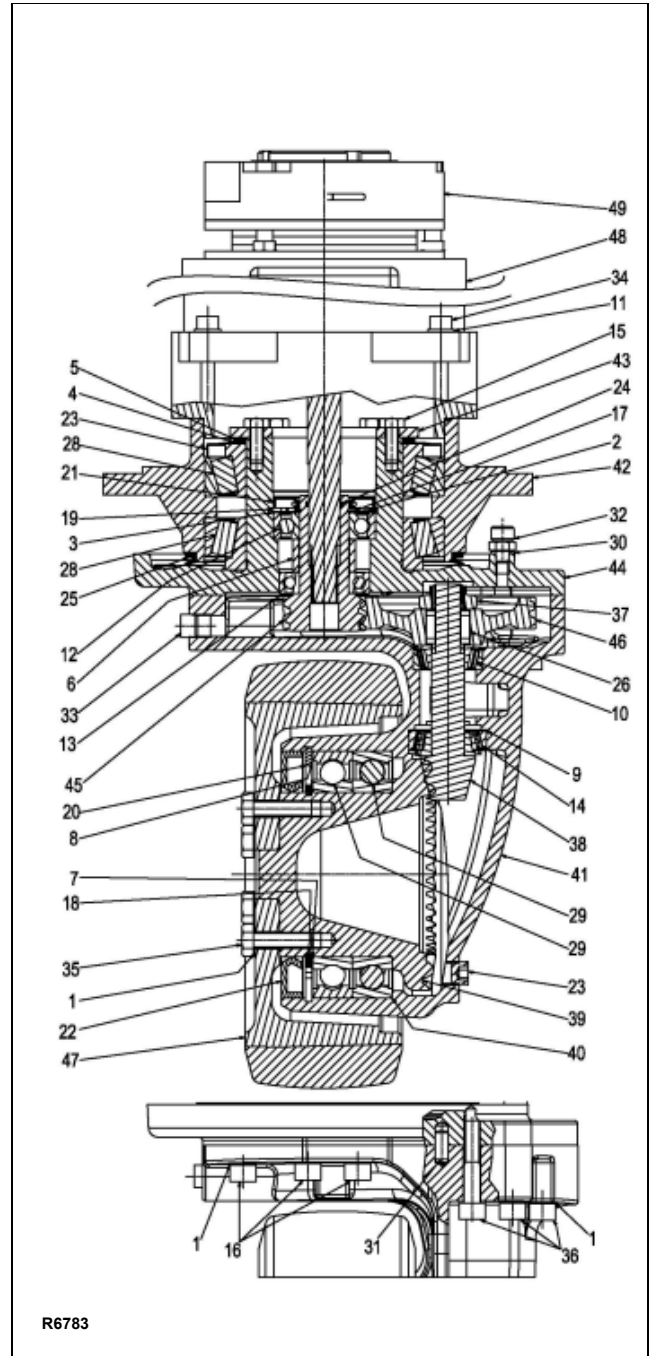

Figure 10-6 Transmission, Motor, Brake Assembly

10-5.2.Adjustment

1. Raise the forks until switch (21, Figure 10-2) is aligned with the detent on the frame.
2. The detent should trigger the lift limit switch and stop the hydraulic pump and motor.
3. If necessary, loosen screws (17) and adjust mounting plate (25).
4. Tighten screws (17) and recheck.

10-6.DEADMAN SWITCH

10-6.1.Replacement

1. Disconnect harness (1, [Figure 12-15](#)) from the deadman switch (30, [Figure 12-2](#)).
2. Remove the two screws (14), two lock washers (29), two flat washers (15) and switch (30) from bracket (17).
3. Position the new switch (30) on bracket (17) and secure with two screws (14), two lock washers (29), two flat washers (15).
4. Reconnect harness (1, [Figure 12-15](#)) to the deadman switch (30, [Figure 12-2](#)).

SECTION 11 OPTIONAL EQUIPMENT

11-1.LOAD BACKREST.

A load backrest is available for addition to the lift truck to allow handling of high loads.

NOTES

SECTION 12
ILLUSTRATED PARTS BREAKDOWN

Following is an illustrated parts breakdown of assemblies and parts associated with the EPJ-60R Lift Truck.

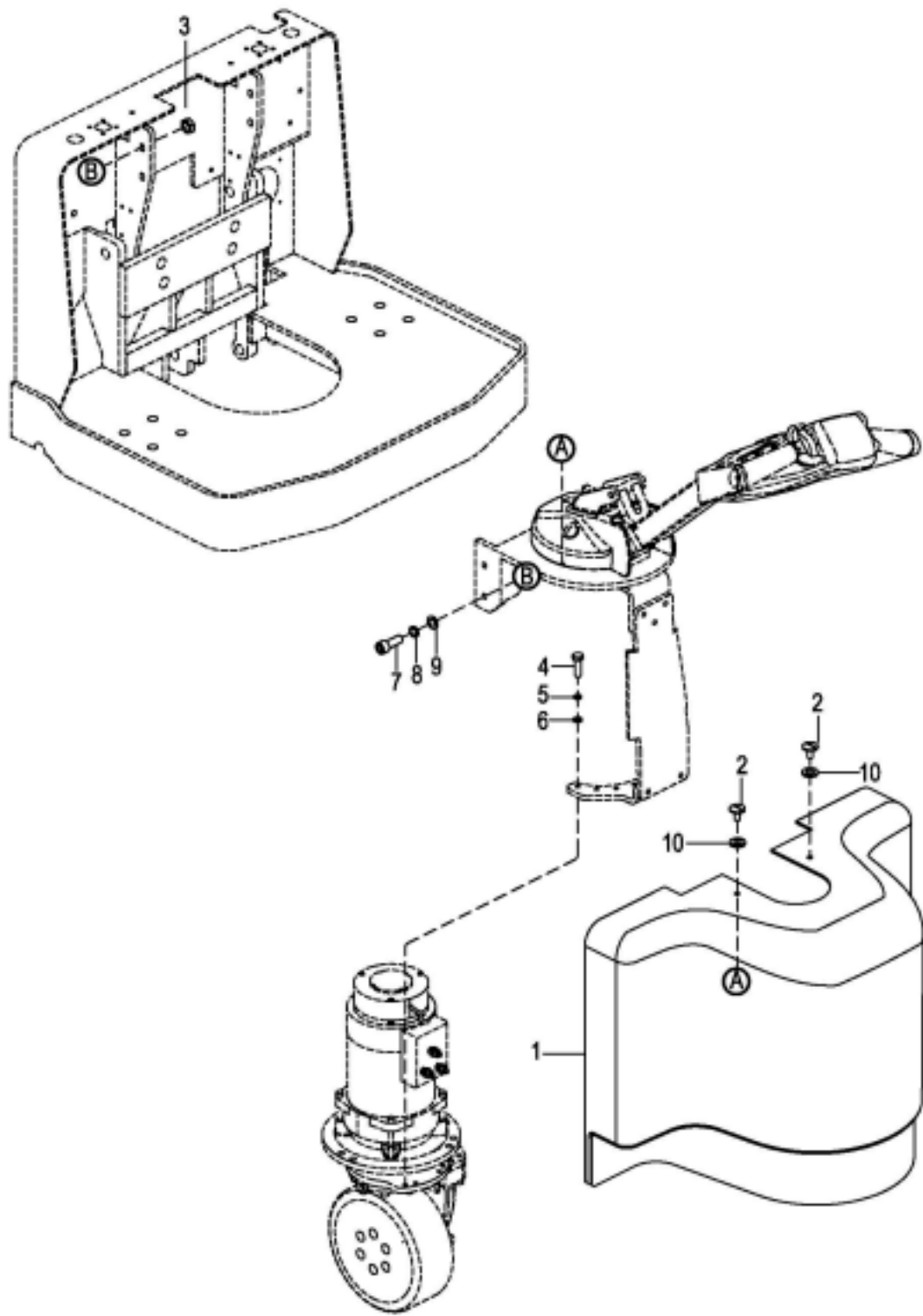

R6776A

Figure 12-1 Steering System

| INDEX NO. | PART NO. | PART NAME | NO. REQD. |
|-----------|----------------|------------------|-----------|
| 1 | 1280-000002-00 | COVER | 1 |
| 2 | 0000-000368-00 | SCREW, M8 X 12 | 2 |
| 3 | 0000-000553-00 | NUT, M10 | 4 |
| 4 | 0000-000274-00 | BOLT, M6 X 25 | 8 |
| 5 | 0000-000056-00 | WASHER, LOCK, M6 | 8 |

| INDEX NO. | PART NO. | PART NAME | NO. REQD. |
|-----------|----------------|-------------------|-----------|
| 6 | 0000-000380-00 | WASHER, FLAT, M6 | 8 |
| 7 | 0000-000155-00 | SCREW, M10 X 40 | 4 |
| 8 | 0000-000063-00 | WASHER, LOCK, M10 | 4 |
| 9 | 0000-000007-00 | WASHER, FLAT, M10 | 4 |
| 10 | 2214-150002-00 | WASHER | 2 |

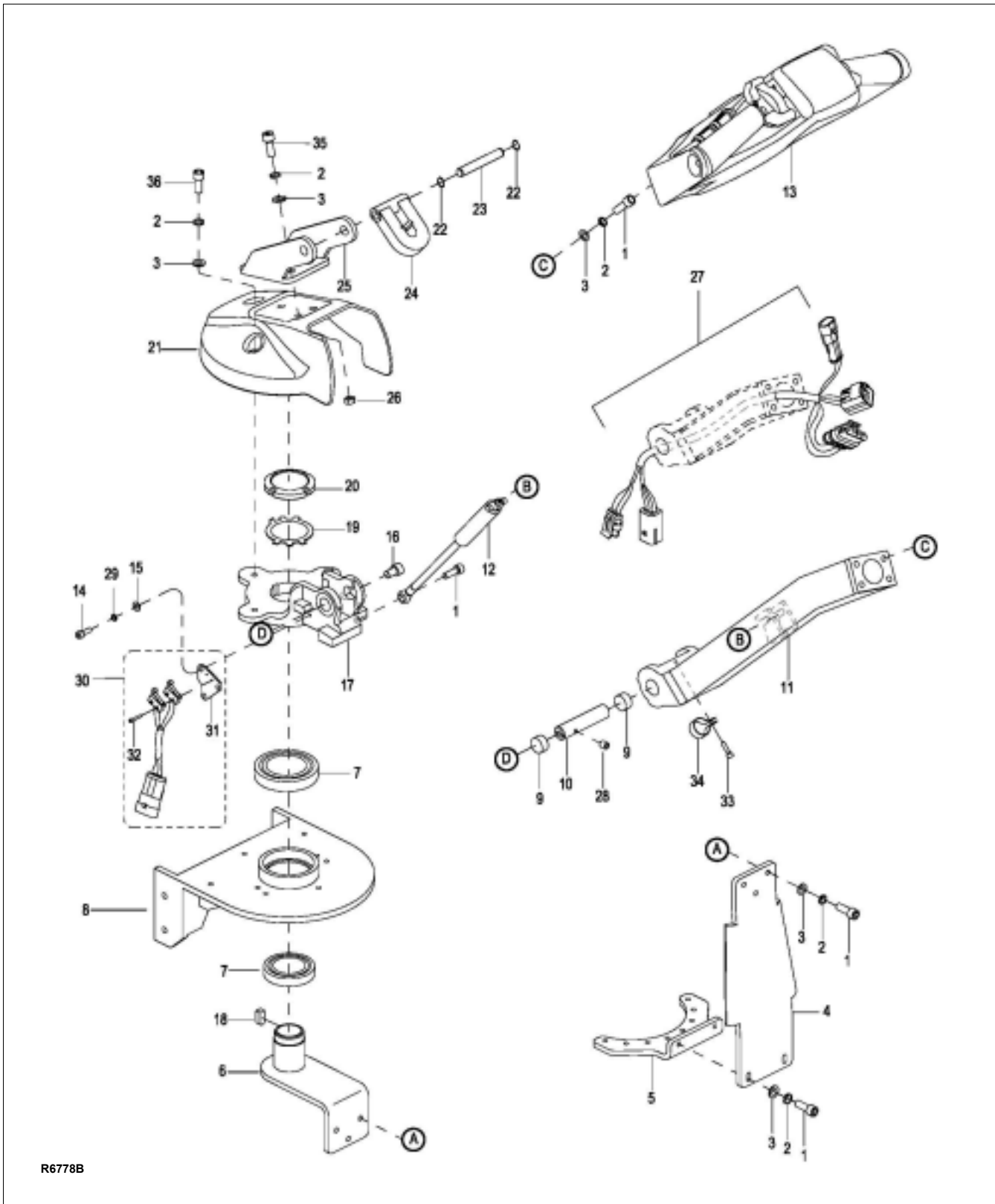

R6778B

Figure 12-2 Steering Arm

| INDEX NO. | PART NO. | PART NAME | NO. REQD. |
|-----------|----------------|----------------------------|-----------|
| 1 | 0000-000322-00 | SCREW, M8 X 25 | 10 |
| 2 | 0000-000159-00 | WASHER, LOCK, M8 | 15 |
| 3 | 0000-000176-00 | WASHER, FLAT, M8 | 15 |
| 4 | 1280-300002-00 | PLATE | 1 |
| 5 | 1280-300001-00 | BRACKET | 1 |
| 6 | 1280-330000-00 | BRACKET, STEERING | 1 |
| 7 | 0000-000142-00 | BEARING, 6011-2Z | 2 |
| 8 | 1280-310000-00 | BRACKET, MOUNTING | 1 |
| 9 | 0000-000029-00 | BEARING, 2012 | 2 |
| 10 | 1120-300003-00 | SHAFT | 1 |
| 11 | 1280-320000-0A | CONTROL ARM | 1 |
| 12 | 1120-320000-00 | GAS SPRING | 1 |
| 13 | — | CONTROL HEAD (FIGURE 12-3) | REF |
| 14 | 0000-000609-00 | SCREW, M4 X 10 | 2 |
| 15 | 0000-000702-00 | WASHER, FLAT, M4 | 2 |
| 16 | 0000-000030-00 | SCREW, M10 X 16 | 1 |
| 17 | 2130-300001-00 | BRACKET, STEERING | 1 |
| 18 | 0000-000681-00 | KEY, C8 X 7 X 14 | 1 |

| INDEX NO. | PART NO. | PART NAME | NO. REQD. |
|-----------|------------------|-----------------------|-----------|
| 19 | 0000-000143-00 | WASHER, LOCK, M52 | 1 |
| 20 | 0000-000114-00 | NUT, M52 X 1.5 | 1 |
| 21 | 1280-300005-00 | COVER | 1 |
| 22 | 0000-000683-00 | RETAINING RING, M12 | 2 |
| 23 | 1280-300003-00 | SHAFT | 1 |
| 24 | 1280-300004-00 | SUPPORT BLOCK | 1 |
| 25 | 1280-350000-00 | SUPPORT BRACKET | 1 |
| 26 | 0000-000550-00 | NUT, M8 | 3 |
| 27 | 1280-520002-00 | WIRING HARNESS | 1 |
| 28 | .0000-000429-00 | SCREW, M5 X 8 | 1 |
| 29 | 0000-000122-00 | WASHER, LOCK, M4 | 2 |
| 30 | 1280-520005-00-B | BRAKE SWITCH ASSEMBLY | 1 |
| 31 | 1120-300006-00 | BRACKET, SWITCH | 1 |
| 32 | 0000-000377-00 | SCREW, M2 X 20 | 2 |
| 33 | 0000-000004-00 | SCREW, M5 X 12 | 1 |
| 34 | 0000-000491-00 | CLAMP | 1 |
| 35 | 0000-000278-00 | SCREW, M8 X 30 | 3 |
| 36 | 0000-000321-00 | SCREW, M8 X 20 | 3 |

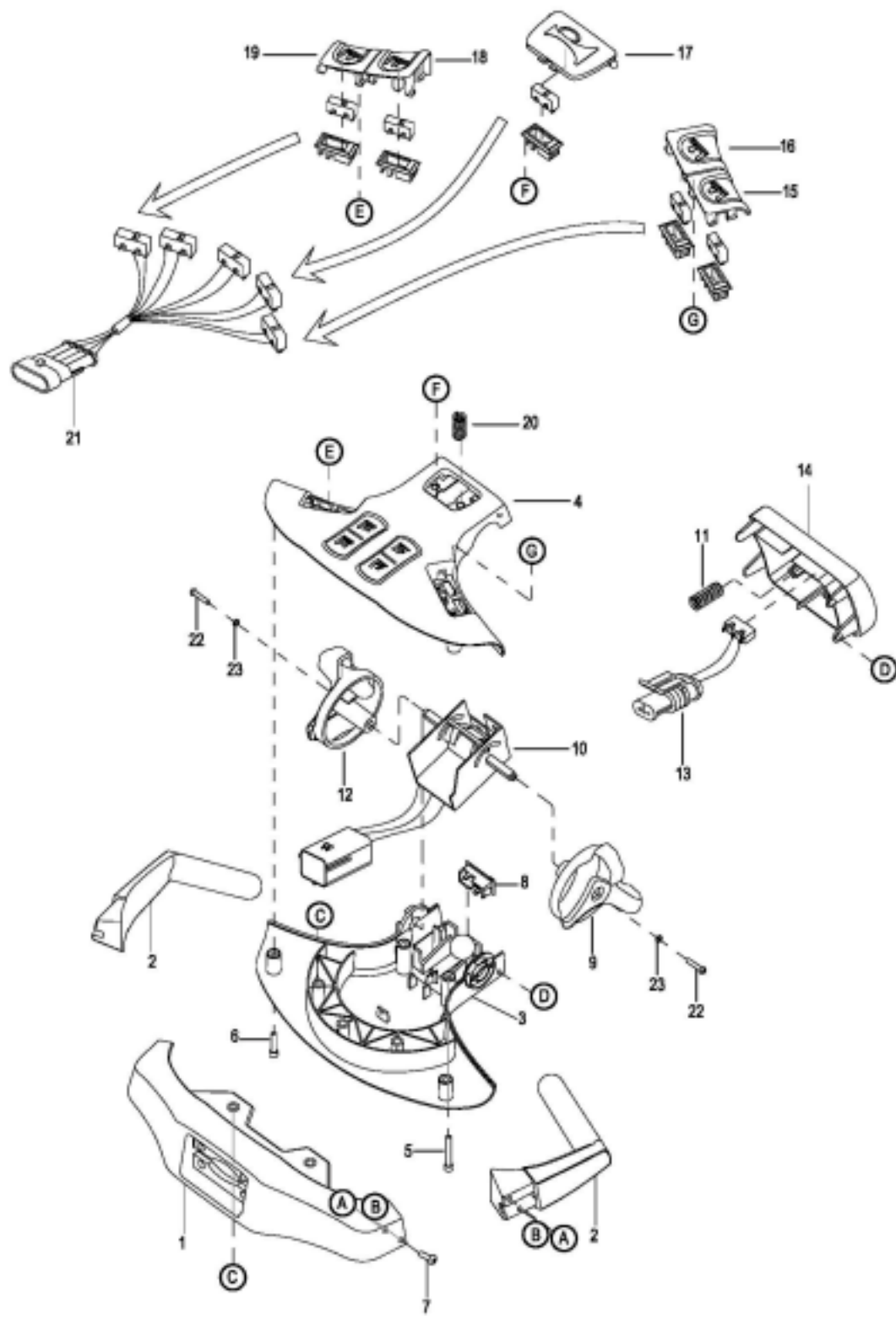

R6780A

Figure 12-3 Control Head

| INDEX NO. | PART NO. | PART NAME | NO. REQD. |
|-----------|----------------|------------------------------|-----------|
| — | 1280-360000-00 | CONTROL HEAD | 1 |
| 1 | 1280-360001-00 | • BRACKET | 1 |
| 2 | 1280-360002-00 | • HANDLE | 2 |
| 3 | 1280-360004-00 | • COVER | 1 |
| 4 | 1280-360003-00 | • COVER | 1 |
| 5 | 0000-000320-00 | • SCREW, M6 X 35 | 2 |
| 6 | 0000-000032-00 | • SCREW, M6 X 25 | 2 |
| 7 | 0000-000179-00 | • SCREW, M6 X 10 | 4 |
| 8 | 1280-360013-00 | • BRACKET | 6 |
| 9 | 1280-360006-00 | • CONTROL KNOB, LIFT | 1 |
| 10 | 1220-520008-0C | • POTENTIOMETER | 1 |
| 11 | 1120-343003-00 | • SPRING | 2 |
| 12 | 1280-360005-00 | • CONTROL KNOB, RIGHT | 1 |
| 13 | 1220-520005-0C | • SWITCH ASSEMBLY, REVERSING | 1 |

| INDEX NO. | PART NO. | PART NAME | NO. REQD. |
|-----------|----------------|------------------------------|-----------|
| 14 | 1280-360012-00 | • EMERGENCY REVERSING BUTTON | 1 |
| 15 | 1280-360009-00 | • BUTTON, LOWERING, LEFT | 1 |
| 16 | 1280-360007-00 | • BUTTON, LIFT, LEFT | 1 |
| 17 | 1280-360011-00 | • BUTTON, HORN | 1 |
| 18 | 1280-360008-00 | • BUTTON, LIFT, RIGHT | 1 |
| 19 | 1280-360010-00 | • BUTTON, LOWERING, RIGHT | 1 |
| 20 | 1280-360014-00 | • SPRING | 6 |
| 21 | 1220-520006-0C | • HARNESS ASSY, SWITCH | 1 |
| 22 | 0000-000037-00 | • SCREW, M3 x 12 | 2 |
| 23 | 0000-000038-00 | • WASHER, LOCK, M3 | 2 |

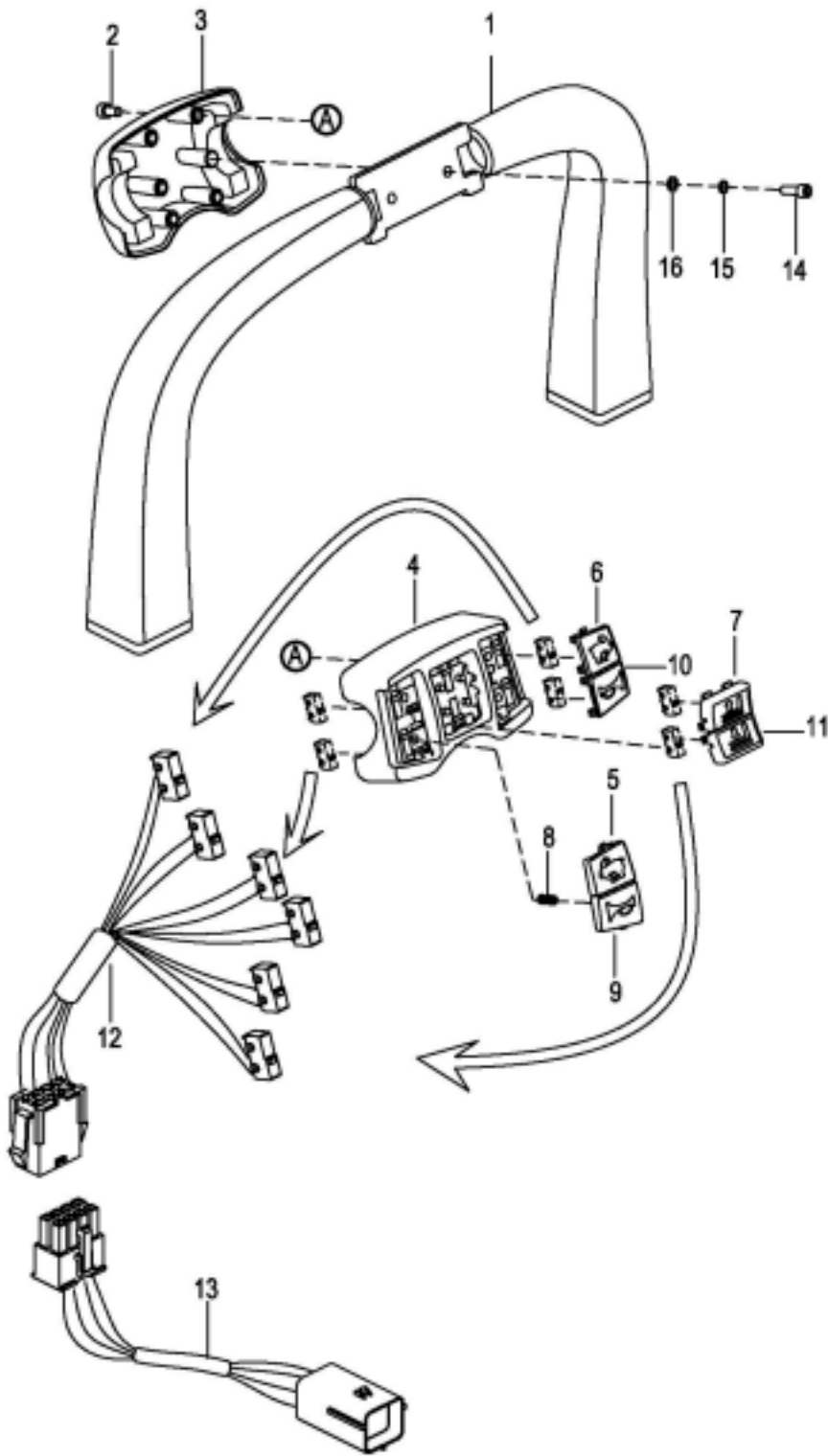

R6785A

Figure 12-4 Grab Bar Assembly

| INDEX NO. | PART NO. | PART NAME | NO. REQD. |
|-----------|----------------|---------------------|-----------|
| 1 | 1280-140000-00 | GRAB BAR | 1 |
| 2 | 0000-000077-00 | SCREW, M6 X 12 | 4 |
| 3 | 1280-141002-00 | COVER | 1 |
| 4 | 1280-141001-00 | COVER | 1 |
| 5 | 1280-141005-00 | HIGH SPEED BUTTON-L | 1 |
| 6 | 1280-141006-00 | HIGH SPEED BUTTON-R | 1 |
| 7 | 1280-141003-00 | LIFT BUTTON | 1 |
| 8 | 1280-141009-00 | SPRING | 8 |

| INDEX NO. | PART NO. | PART NAME | NO. REQD. |
|-----------|----------------|----------------------|-----------|
| 9 | 1280-141007-00 | HORN BUTTON-L | 1 |
| 10 | 1280-141008-00 | HORN BUTTON-R | 1 |
| 11 | 1280-141004-00 | LOWER BUTTON | 1 |
| 12 | 1280-520004-00 | HARNESS ASSY, SWITCH | 1 |
| 13 | 1280-520003-00 | WIRE HARNESS | 1 |
| 14 | 0000-000032-00 | SCREW, M6 X 25 | 4 |
| 15 | 0000-000056-00 | WASHER, LOCK, M6 | 4 |
| 16 | 0000-000380-00 | WASHER, FLAT, M6 | 4 |

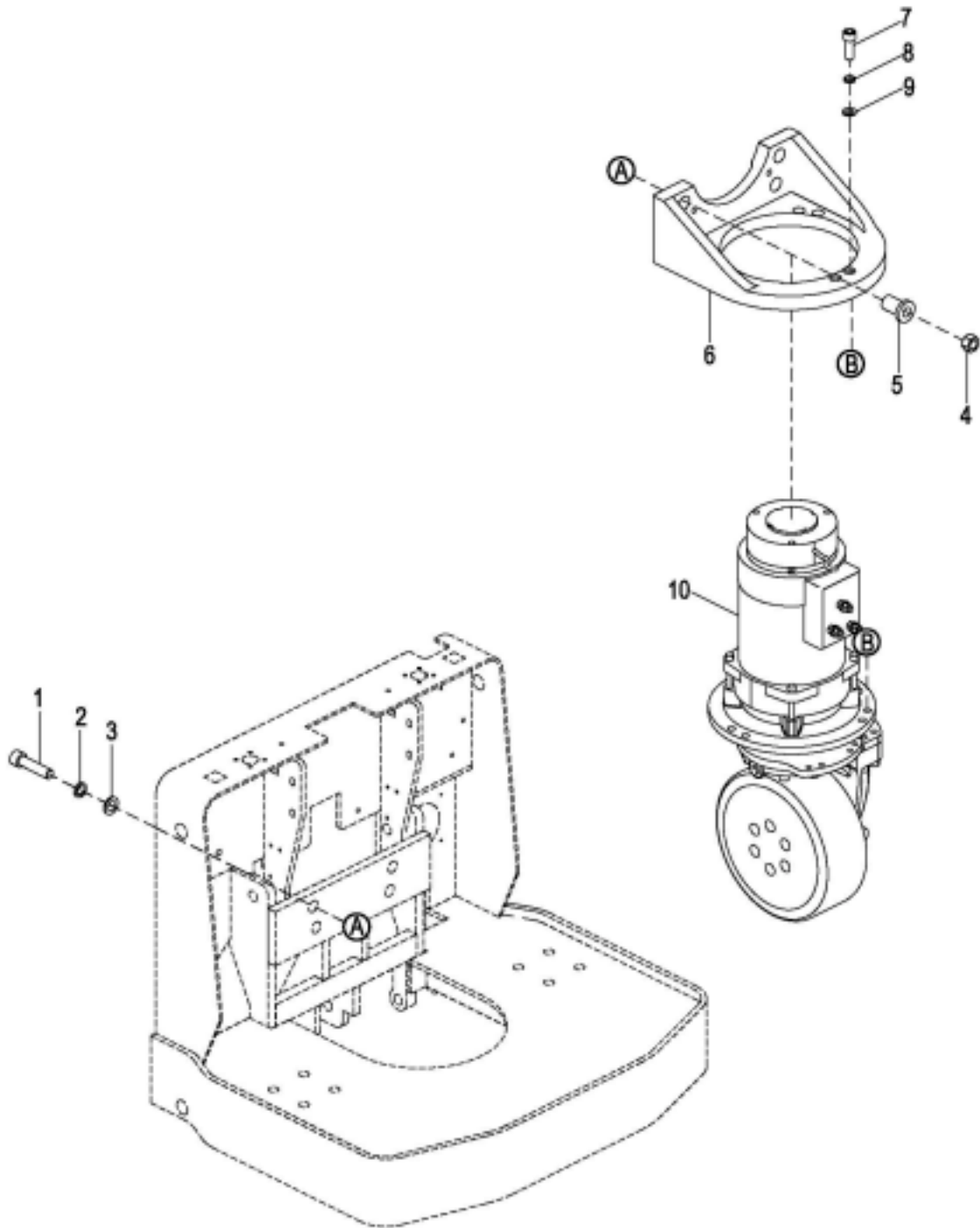

R6781

Figure 12-5 Drive System

| INDEX NO. | PART NO. | PART NAME | NO. REQD. |
|-----------|----------------|---------------------|-----------|
| 1 | 0000-000432-00 | SCREW, M16 X 80 | 4 |
| 2 | 0000-000191-00 | WASHER, LOCK, M16 | 4 |
| 3 | 0000-000220-00 | WASHER, FLAT, M16 | 4 |
| 4 | 0000-000187-00 | NUT, M16 | 4 |
| 5 | 1280-200002-00 | BUSHING | 4 |
| 6 | 1280-200001-00 | MOUNT, TRANSMISSION | 1 |

| INDEX NO. | PART NO. | PART NAME | NO. REQD. |
|-----------|----------------|----------------------------------------------------------------------------|-----------|
| 7 | 0000-000516-00 | SCREW, M12 X 40 | 6 |
| 8 | 0000-000060-00 | WASHER, LOCK, M12 | 6 |
| 9 | 0000-000373-00 | WASHER, FLAT, M12 | 4 |
| 10 | — | TRANSMISSION, MOTOR, BRAKE ASSEMBLY (FIG- URE 12-6) | REF |

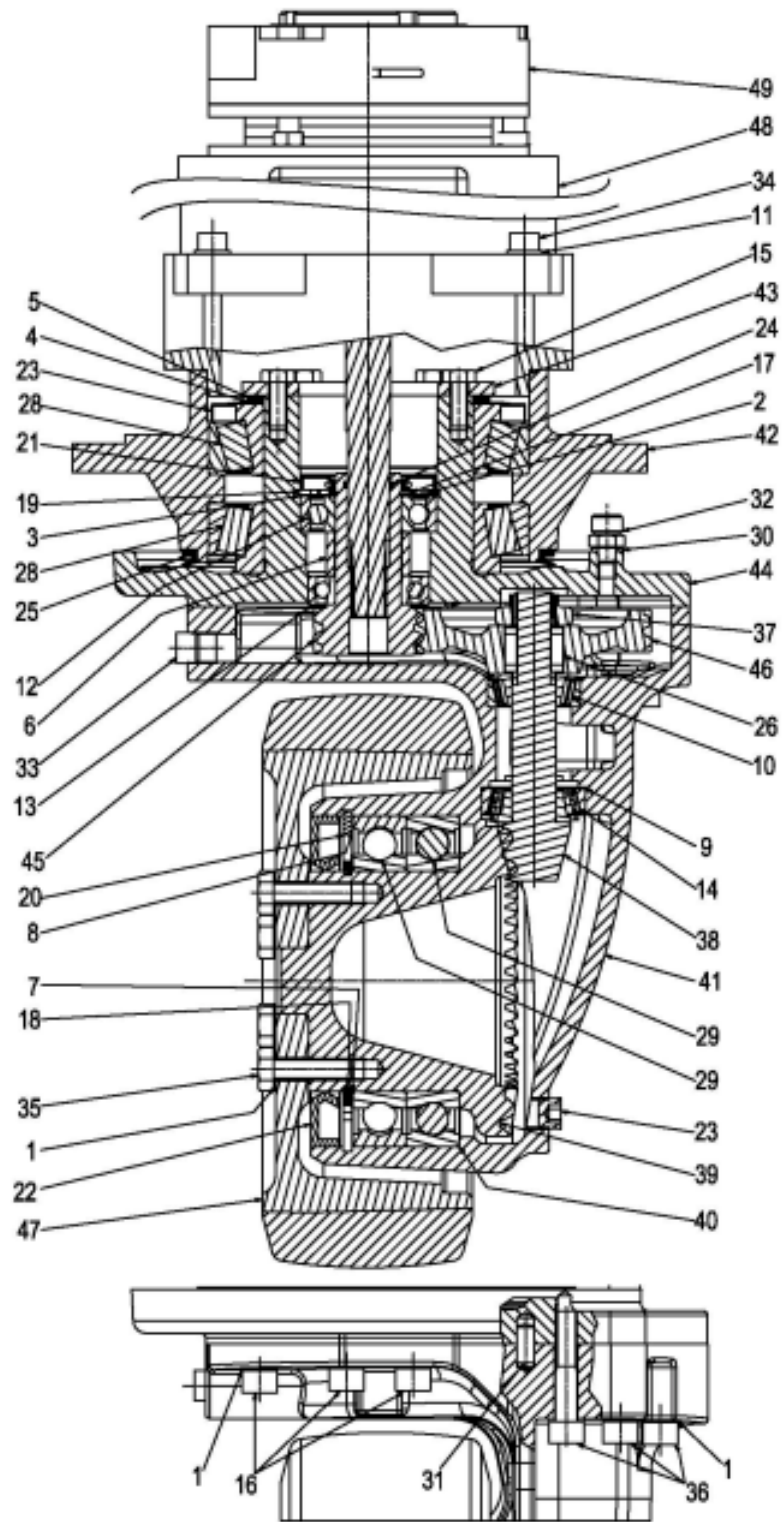

R6783

Figure 12-6 Transmission, Motor, Brake Assembly

| INDEX NO. | PART NO. | PART NAME | NO. REQD. |
|-----------|----------------|-------------------------------------|-----------|
| — | 1280-200000-00 | TRANSMISSION, MOTOR, BRAKE ASSEMBLY | 1 |
| 1 | 1280-210001-00 | • SNAP RING, 10.5 X 16 X 1.5 | 18 |
| 2 | 1280-210002-00 | • SNAP RING, 30.3 X 44.0 | 1 |
| 3 | 1280-210003-00 | • SNAP RING, 55.3 X 61.7 | 1 |
| 4 | 1280-210004-00 | • SNAP RING, 95.2 X 109.8 | 1 |
| 5 | 1280-210005-00 | • SNAP RING, 95.3 X 109.5 X 2.5 | 1 |
| 6 | 1280-210006-00 | • SUPPORT, CENTER, 30.2 X 38 X 20 | 1 |
| 7 | 1280-210007-00 | • ELASTIC COLLAR, 100.5 X 114.5 | 1 |
| 8 | 1280-210008-00 | • ELASTIC COLLAR, 135.5 X 149.5 | 1 |
| 9 | 1280-210009-00 | • ELASTIC COLLAR, 40.3 X 46.7 | 1 |
| 10 | 1280-210010-00 | • BEARING, 32004 | 1 |
| 11 | 1280-210011-00 | • SNAP RING, 8.4 X 17 | 1 |
| 12 | 1280-210012-00 | • BEARING, 6206-2RS | 1 |
| 13 | 1280-210013-00 | • BEARING, 6206 | 1 |
| 14 | 1280-210014-00 | • BEARING, 30204 | 1 |
| 15 | 1280-210015-00 | • BOLT, M8 X 20 | 8 |
| 16 | 1280-210016-00 | • BOLT, M10 X 25 | 6 |
| 17 | 1280-210017-00 | • SNAP RING, M30 | 1 |
| 18 | 1280-210018-00 | • ELASTIC COLLAR, M100 | 1 |
| 19 | 1280-210019-00 | • ELASTIC COLLAR, M62 | 1 |
| 20 | 1280-210020-00 | • ELASTIC COLLAR, M150 | 1 |
| 21 | 1280-210021-00 | • BEARING SEAL, 30 X 62 X 7 | 1 |
| 22 | 1280-210022-00 | • BEARING SEAL, 100 X 150 X 13 | 1 |

| INDEX NO. | PART NO. | PART NAME | NO. REQD. |
|-----------|----------------|--------------------------------|-----------|
| 23 | 1280-210023-00 | • BEARING SEAL, 32019 | 1 |
| 24 | 1280-210024-00 | • ELASTIC COLLAR, 1.78 X 18.77 | 1 |
| 25 | 1280-210025-00 | • V-SEAL, V160L | 1 |
| 26 | 1280-210026-00 | • KEY, 6 X 6 X 20 | 2 |
| 27 | 1280-210027-00 | • KEY, 8 X 7 X 15 | 1 |
| 28 | 1280-210028-00 | • BEARING, 32019 | 2 |
| 29 | 1280-210029-00 | • BEARING, 6020 | 2 |
| 30 | 1280-210030-00 | • SNAP RING, 8 X 14 X 1.5 | 1 |
| 31 | 1280-210031-00 | • PIN, M8 X 20 | 5 |
| 32 | 1280-210032-00 | • NUT, M8 X 1.25 | 1 |
| 33 | 1280-210033-00 | • SCREW | 2 |
| 34 | 1280-210034-00 | • SCREW, M8 X 75 | 4 |
| 35 | 1280-210035-00 | • SCREW, M10 X 30 | 6 |
| 36 | 1280-210036-00 | • SCREW, M10 X 50 | 6 |
| 37 | 1280-210037-00 | • NUT | 1 |
| 38 | 1280-210038-00 | • GEAR AXLE | 1 |
| 39 | 1280-210039-00 | • GEAR, Z=37Z | 1 |
| 40 | 1280-210040-00 | • SNAP RING, 133.4 X 149.7 | 1 |
| 41 | 1280-210041-00 | • GEAR CASE | 1 |
| 42 | 1280-210042-00 | • BEARING BLOCK | 1 |
| 43 | 1280-210043-00 | • SNAP RING | 1 |
| 44 | 1280-210044-00 | • BEARING BLOCK | 1 |
| 45 | 1280-210045-00 | • GEAR | 1 |
| 46 | 1280-210046-00 | • GEAR | 1 |
| 47 | 1280-210047-00 | • DRIVE WHEEL, PU | 1 |
| 47 | 1280-200001-00 | • DRIVE WHEEL, RUBBER | 1 |
| 48 | 1280-210048-00 | • MOTOR | 1 |
| 49 | 1280-210049-00 | • BRAKE | 1 |

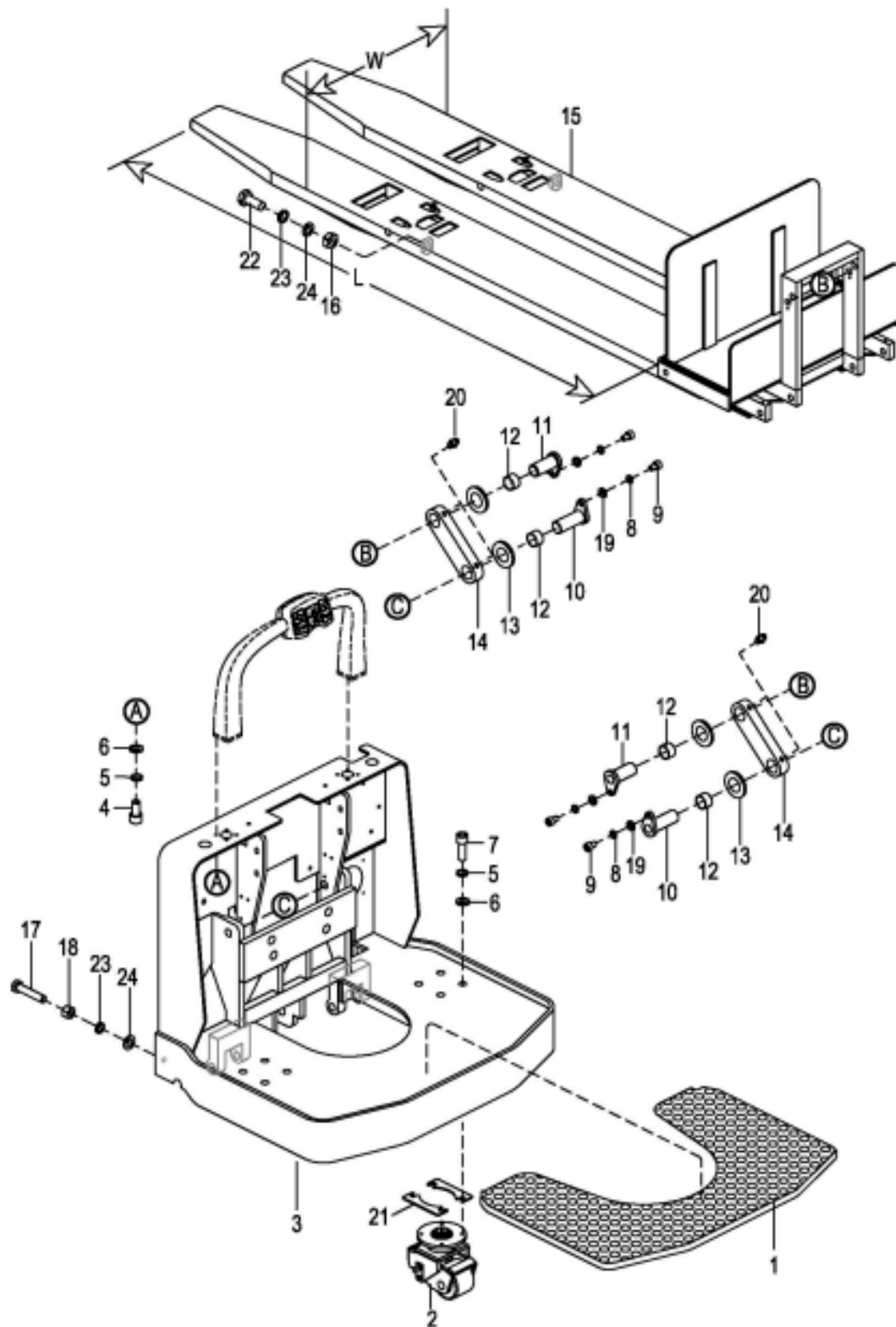

R6786A

Figure 12-7 Frame

| INDEX NO. | PART NO. | PART NAME | NO. REQD. |
|-----------|----------------|------------------------------------|-----------|
| 1 | 1280-100003-00 | MAT, CUSHION | 1 |
| 2 | — | CASTER ASSEMBLY (FIG- URE 12-9) | 2 |
| 3 | 1280-120000-00 | FRAME, BACK | 1 |
| 4 | 0000-000109-00 | SCREW, M8 X 16 | 8 |
| 5 | 0000-000159-00 | WASHER, LOCK, M8 | 16 |
| 6 | 0000-000176-00 | WASHER, FLAT, M8 | 16 |
| 7 | 0000-000154-00 | SCREW, M8 X 35 | 8 |
| 8 | 0000-000056-00 | WASHER, LOCK, M6 | 4 |
| 9 | 0000-000055-00 | SCREW, M6 X 16 | 4 |
| 10 | 1280-131000-00 | SHAFT | 2 |
| 11 | 1280-132000-00 | SHAFT | 2 |
| 12 | 0000-000694-00 | BUSHING | 4 |

| INDEX NO. | PART NO. | PART NAME | NO. REQD. |
|-----------|----------------|----------------------|-----------|
| 13 | 0000-000692-00 | WASHER, FLAT, M22 | 4 |
| 14 | 1280-130001-00 | LINK | 2 |
| 15 | 1260-110000-00 | FRAME, FORK, 48 INCH | 1 |
| 15 | 1280-110000-00 | FRAME, FORK, 96 INCH | 1 |
| 16 | 0000-000630-00 | NUT, M12 | 2 |
| 17 | 0000-000286-00 | BOLT, M12 X 60 | 2 |
| 18 | 0000-000630-00 | NUT, M12 | 2 |
| 19 | 0000-000380-00 | WASHER, FLAT, M6 | 4 |
| 20 | 0000-000411-00 | GREASE FITTING | 4 |
| 21 | 2140-140005-00 | SHIM | AR |
| 22 | 0000-000285-00 | SCREW, M12 X 35 | 2 |
| 23 | 0000-000060-00 | WASHER, LOCK, M12 | 4 |
| 24 | 0000-000373-00 | WASHER, FLAT, M12 | 4 |

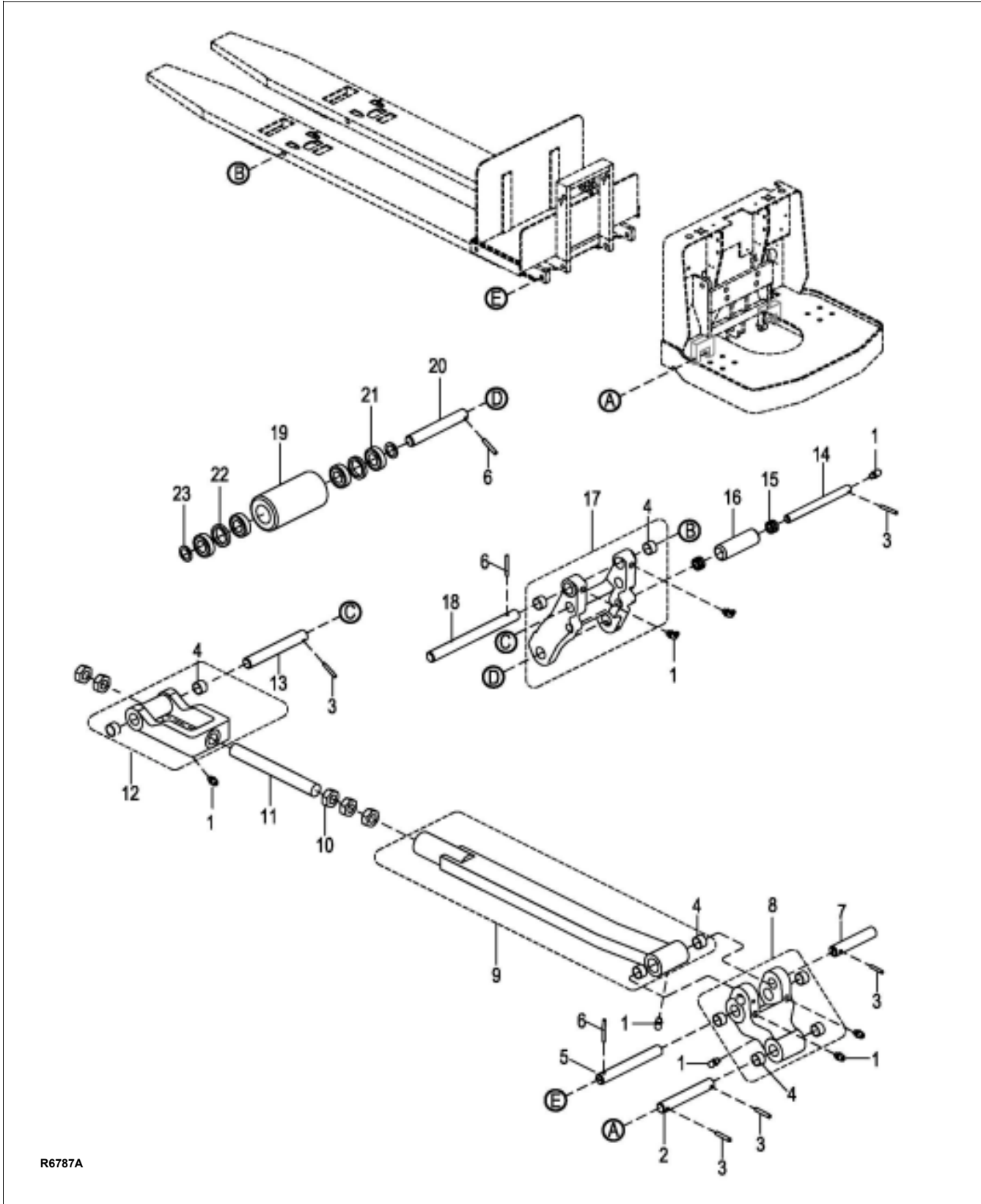

R6787A

Figure 12-8 Lift Linkage

| INDEX NO. | PART NO. | PART NAME | NO. REQD. |
|-----------|----------------|----------------------|-----------|
| 1 | 0000-000587-00 | GREASE FITTING, M6 | 16 |
| 2 | 1280-130002-00 | SHAFT | 2 |
| 3 | 0000-000410-00 | PIN, M6 X 40 | 10 |
| 4 | 0000-000693-00 | BUSHING, CSB-20 2225 | 20 |
| 5 | 1280-130003-00 | SHAFT | 2 |
| 6 | 0000-000414-00 | PIN, M6 X 50 | 6 |
| 7 | 1280-130005-00 | SHAFT | 2 |
| 8 | 1280-130004-00 | LINK | 2 |
| 9 | 1260-133000-00 | TENSION BAR, 48 INCH | 1 |
| 9 | 1280-133000-00 | TENSION BAR, 96 INCH | 1 |
| 10 | 0000-000691-00 | NUT, M22 X 1.5 | 10 |
| 11 | 1280-130014-00 | BAR | 2 |
| 12 | 1280-130007-00 | END, TENSION BAR | 2 |

| INDEX NO. | PART NO. | PART NAME | NO. REQD. |
|-----------|----------------|------------------|-----------|
| 13 | 1280-130008-00 | SHAFT | 2 |
| 14 | 1280-130012-00 | AXLE | 2 |
| 15 | 0000-000695-00 | BUSHING, 162215 | 4 |
| 16 | 1280-130013-00 | ROLLER | 2 |
| 17 | 1280-130010-00 | BRACKET, WHEEL | 2 |
| 18 | 1280-130006-00 | SHAFT | 2 |
| 19 | 1280-130011-00 | LOAD WHEEL | 2 |
| 20 | 1280-130009-00 | AXLE | 2 |
| 21 | 0000-000100-00 | BEARING, 6205 | 8 |
| 22 | 1280-134002-00 | WASHER | 4 |
| 23 | 0000-000249-00 | WASHER, FLAT, 24 | 4 |

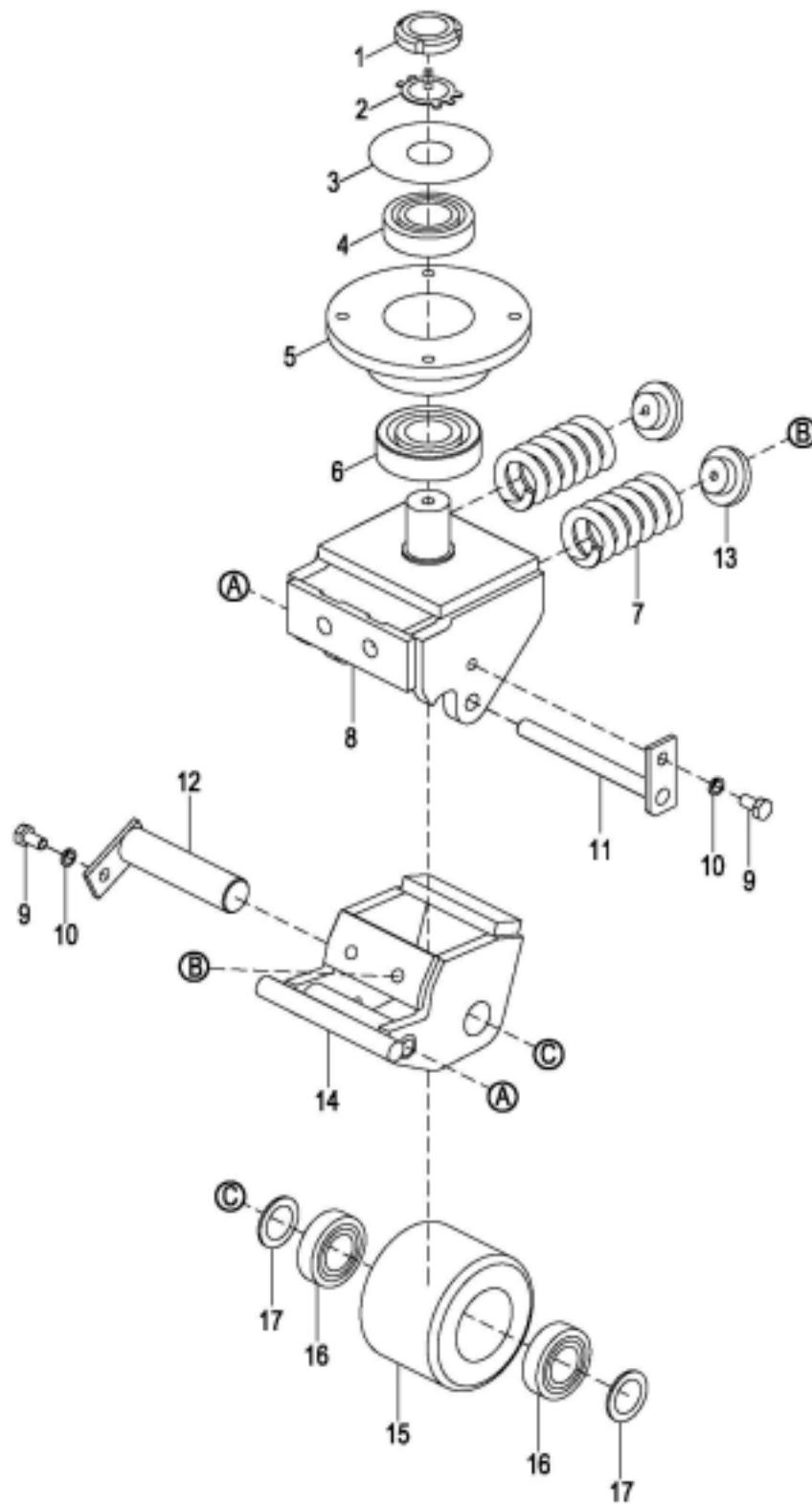

R6788

Figure 12-9 Caster Wheel

| INDEX NO. | PART NO. | PART NAME | NO. REQD. |
|-----------|----------------|---------------------|-----------|
| — | 2140-140000-00 | CASTER WHEEL | 2 |
| 1 | 0000-000093-00 | • NUT, M27 X 1.5 | 1 |
| 2 | 0000-000094-00 | • LOCK RING M27 | 1 |
| 3 | 0000-140001-00 | • RING, SNAP | 1 |
| 4 | 0000-000420-00 | • BEARING, 6206-2RZ | 1 |
| 5 | 2140-140002-00 | • BEARINGBLOCK | 1 |
| 6 | 0000-000421-00 | • BEARING, 6306-2RZ | 1 |
| 7 | 2140-140004-00 | • SPRING | 2 |
| 8 | 2140-141000-00 | • YOKE | 1 |

| INDEX NO. | PART NO. | PART NAME | NO. REQD. |
|-----------|----------------|--------------------|-----------|
| 9 | 0000-000242-00 | BOLT, M8 X 15 | 2 |
| 10 | 0000-000159-00 | • WASHER, LOCK, M8 | 2 |
| 11 | 2140-142000-00 | • HINGE PIN | 1 |
| 12 | 2140-145000-00 | • AXLE | 1 |
| 13 | 2140-140003-00 | • SEAT, SPRING | 2 |
| 14 | 2140-143000-00 | • WHEEL BRACKET | 1 |
| 15 | 2140-144002-00 | • WHEEL, POLY | 1 |
| 16 | 0000-000424-00 | • BEARING, 6205-2Z | 2 |
| 17 | 0000-000249-00 | • WASHER | 2 |

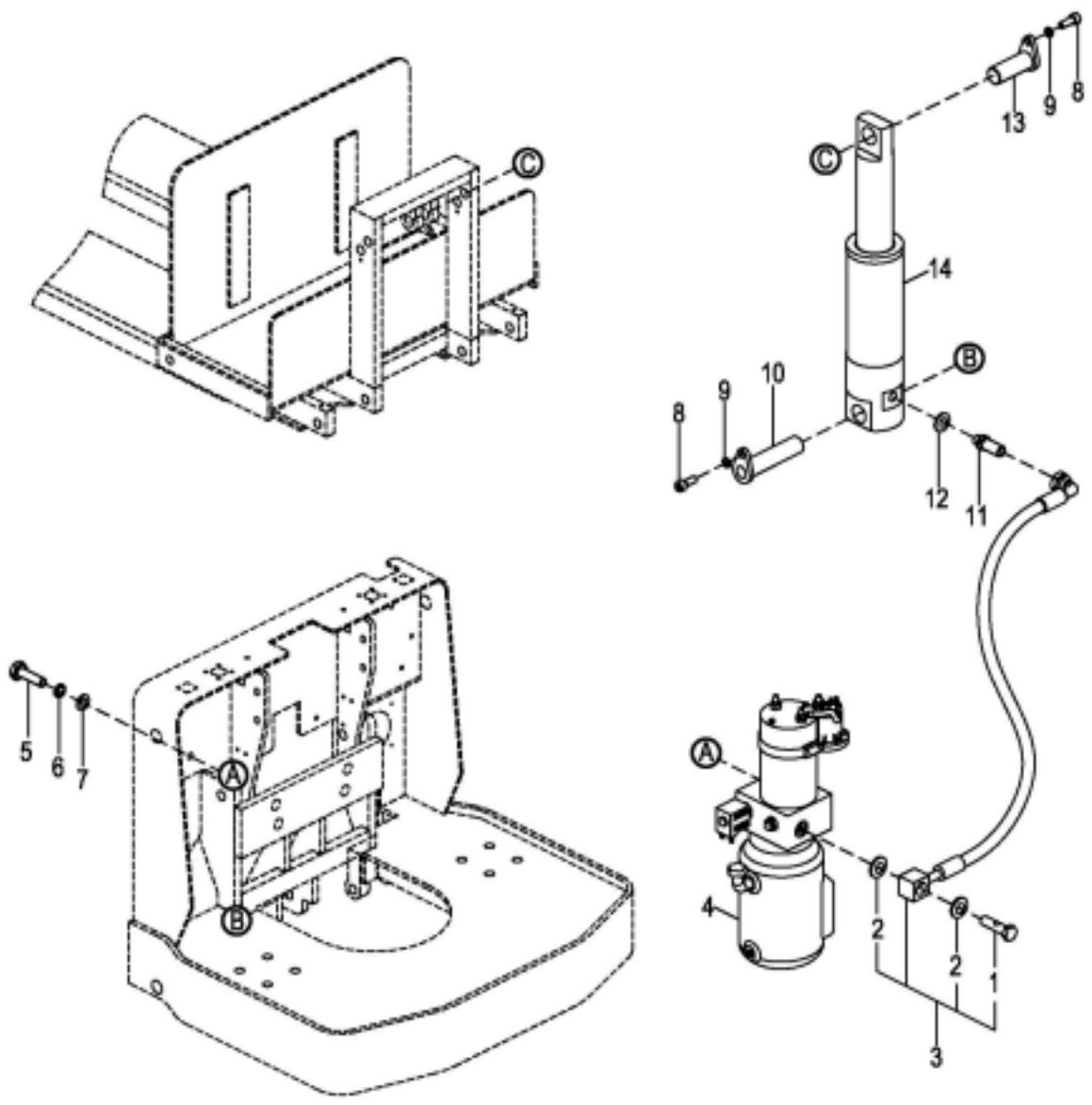

R6789

Figure 12-10 Hydraulic System

| INDEX NO. | PART NO. | PART NAME | NO. REQD. |
|-----------|----------------|-------------------------------------------------------|-----------|
| 1 | 2402-384000-00 | BOLT, G3/8 X 40 | 1 |
| 2 | 0000-000069-00 | SEAL | 2 |
| 3 | 1280-440000-00 | HOSE | 1 |
| 4 | — | PUMP & MOTOR ASSY (FIGURE 12-11) | REF |
| 5 | 0000-000251-00 | SCREW, M10 X 25 | 2 |
| 6 | 0000-000063-00 | WASHER, LOCK, M10 | 2 |
| 7 | 0000-000007-00 | WASHER, FLAT, M10 | 2 |

| INDEX NO. | PART NO. | PART NAME | NO. REQD. |
|-----------|----------------|-------------------------------------------|-----------|
| 8 | 0000-000055-00 | SCREW, M6 X 16 | 2 |
| 9 | 0000-000056-00 | WASHER, LOCK, M6 | 2 |
| 10 | 1280-420000-00 | SHAFT | 1 |
| 11 | 2701-141600-0A | CONNECTOR | 1 |
| 12 | 0000-000044-00 | SEAL | 1 |
| 13 | 1280-410000-00 | SHAFT | 1 |
| 14 | — | CYLINDER (FIGURE 12-12) | REF |

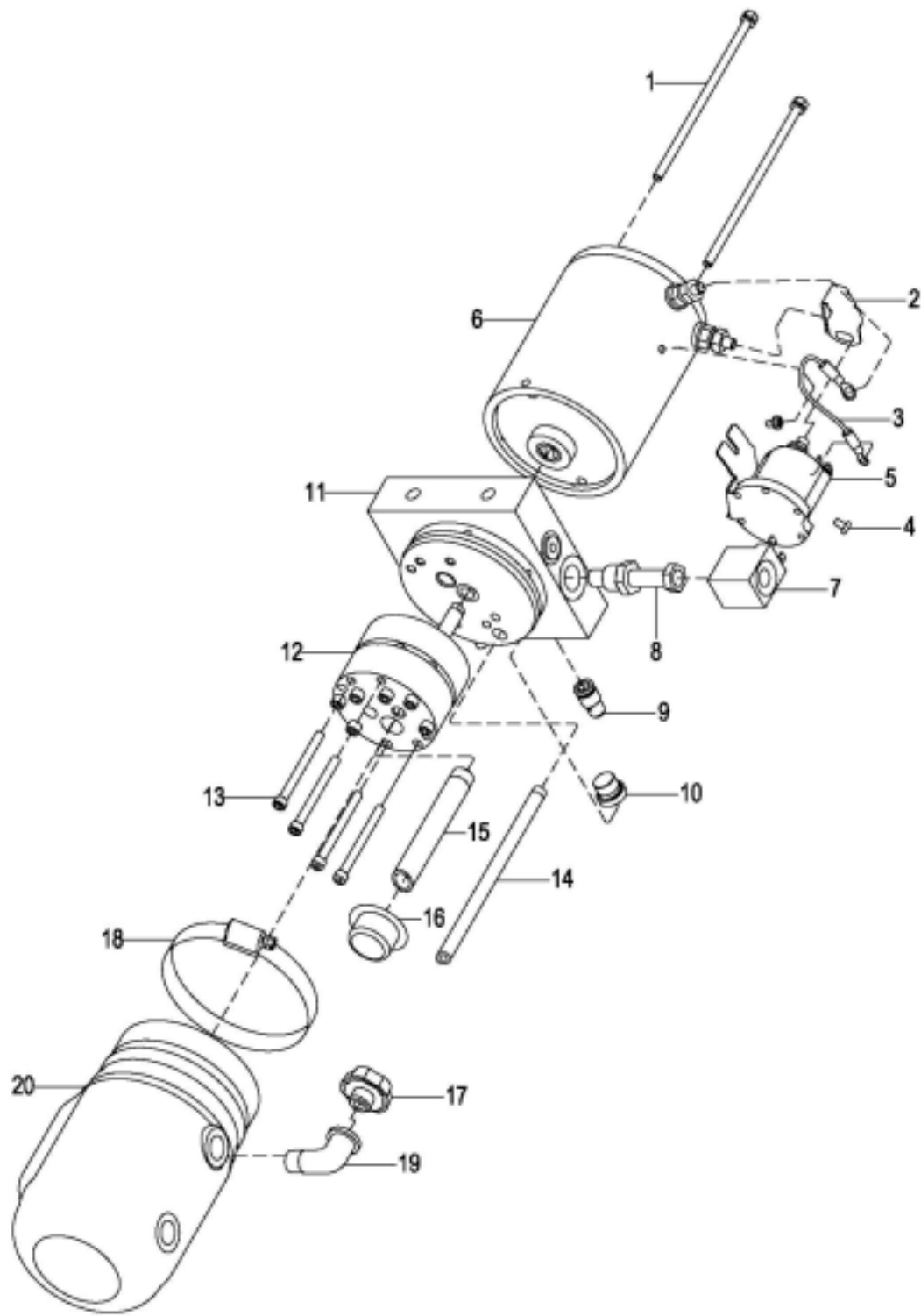

R6790

Figure 12-11 Pump & Motor Assy

| INDEX NO. | PART NO. | PART NAME | NO. REQD. |
|-----------|----------------|-------------------|-----------|
| — | 1220-440000-00 | PUMP & MOTOR ASSY | 1 |
| 1 | 1220-430020-00 | • SCREW | 2 |
| 2 | 1220-430002-00 | • CABLE | 1 |
| 3 | 1220-430005-00 | • WIRE ASSEMBLY | 1 |
| 4 | 1220-430021-00 | • SCREW | 2 |
| 5 | 1220-430004-00 | • CONTACTOR | 1 |
| 6 | 1220-430003-00 | • MOTOR | 1 |
| 7 | 1220-430009-00 | • VALVE, SOLENOID | 1 |
| 8 | 1220-430010-00 | • CARTRIDGE | 1 |
| 9 | 1220-430006-00 | • RELIEF VALVE | 1 |
| 10 | 1220-430022-00 | • PLUG | 1 |

| INDEX NO. | PART NO. | PART NAME | NO. REQD. |
|-----------|----------------|--------------|-----------|
| 11 | 1220-430008-00 | • ADAPTER | 1 |
| 12 | 1220-430011-00 | • PUMP | 1 |
| 13 | 1220-430012-00 | • SCREW | 4 |
| 14 | 1220-420015-00 | • TUBE | 1 |
| 15 | 1220-430016-00 | • TUBE | 1 |
| 16 | 1220-430017-00 | • FILTER | 1 |
| 17 | 1220-430018-00 | • PLUG | 1 |
| 18 | 1220-420014-00 | • CLAMP | 1 |
| 19 | 1220-430023-00 | • PIPE | 1 |
| 20 | 1220-430019-00 | • RESERVOIFR | 1 |

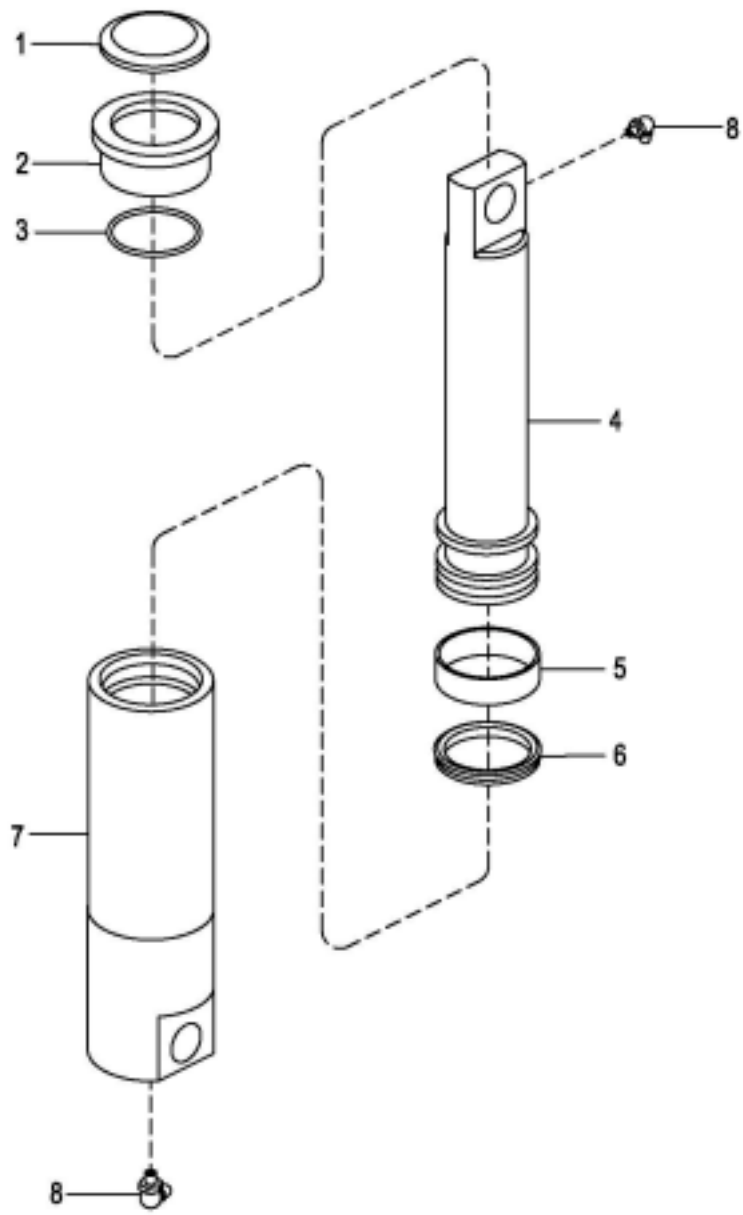

R6791A

Figure 12-12 Lift Cylinder

| INDEX NO. | PART NO. | PART NAME | NO. REQD. |
|-----------|----------------|----------------------------------|-----------|
| — | 1280-430000-00 | LIFT CYLINDER | 1 |
| 1 | 0000-000045-00 | • WIPER RING, 63 X 55 X 5-6.5 | 1 |
| 2 | 1280-430002-00 | • GLAND NUT | 1 |
| 3 | 0000-000690-00 | • O-RING, 60 X 3.1 | 1 |
| 4 | 1280-430001-00 | • PISTON ROD | 1 |

| INDEX NO. | PART NO. | PART NAME | NO. REQD. |
|-----------|----------------|--------------------------------------|-----------|
| 5 | 1280-430003-00 | • GUIDE RING | 1 |
| 6 | 0000-000689-00 | • YX-SEAL, 70 X 60 X 6 | 1 |
| 7 | 1280-431000-00 | • CYLINDER TUBE | 1 |
| 8 | 0000-000411-00 | • GREASE FITTING | 2 |
| — | 1280-SK | SEAL KIT (CONTAINS ITEMS 1, 3, 6) | 1 |

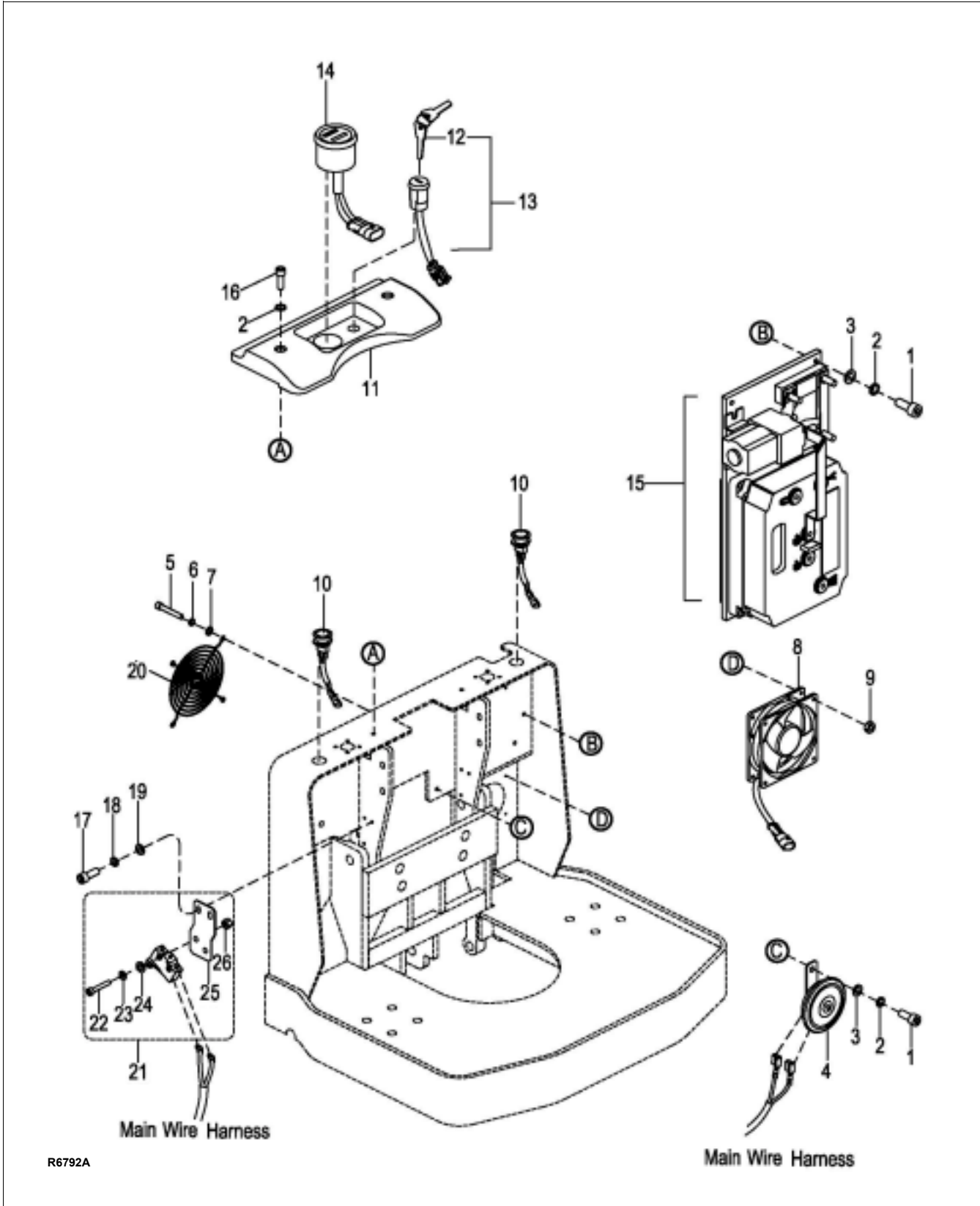

R6792A

Figure 12-13 Electrical System

| INDEX NO. | PART NO. | PART NAME | NO. REQD. |
|-----------|----------------|--------------------------|-----------|
| 1 | 0000-000433-00 | SCREW, M8 X 12 | 4 |
| 2 | 0000-000159-00 | WASHER, LOCK, M8 | 6 |
| 3 | 0000-000194-00 | WASHER, FLAT, M8 | 4 |
| 4 | 1120-500003-00 | HORN | 1 |
| 5 | 0000-000499-00 | SCREW, M4 X 45 | 4 |
| 6 | 0000-000122-00 | WASHER, LOCK, M4 | 4 |
| 7 | 0000-000702-00 | WASHER, FLAT, M4 | 4 |
| 8 | 1220-500003-00 | FAN | 1 |
| 9 | 0000-000209-00 | NUT, M4 | 4 |
| 10 | 1280-520006-00 | SWITCH, AUTOMATIC TRAVEL | 2 |
| 11 | 1280-100001-00 | COVER | 1 |
| 12 | 1120-500016-00 | KEY | 1 |
| 13 | 1115-500002-0C | KEY SWITCH, 3 WAY | 1 |

| INDEX NO. | PART NO. | PART NAME | NO. REQD. |
|-----------|----------------|------------------------------------|-----------|
| 14 | 1120-500007-0C | BATTERY INDICATOR | 1 |
| 15 | — | ELECTRICAL PANEL (FIGURE 12-14) | REF |
| 16 | 0000-000109-00 | SCREW, M8 X 16 | 2 |
| 17 | 0000-000015-00 | SCREW, M6 X 10 | 2 |
| 18 | 0000-000056-00 | WASHER, LOCK, M6 | 2 |
| 19 | 0000-000380-00 | WASHER, FLAT, M6 | 2 |
| 20 | 1220-500004-00 | GUARD | 1 |
| 21 | 1120-500006-00 | SWITCH, LIFTING LIMIT | 1 |
| 22 | 0000-000208-00 | SCREW, M4 X 25 | 2 |
| 23 | 0000-000122-00 | WASHER, LOCK, M4 | 2 |
| 24 | 0000-000702-00 | WASHER, FLAT, M4 | 2 |
| 25 | 1120-500003-00 | BRACKET | 1 |
| 26 | 0000-000209-00 | NUT, M4 | 2 |

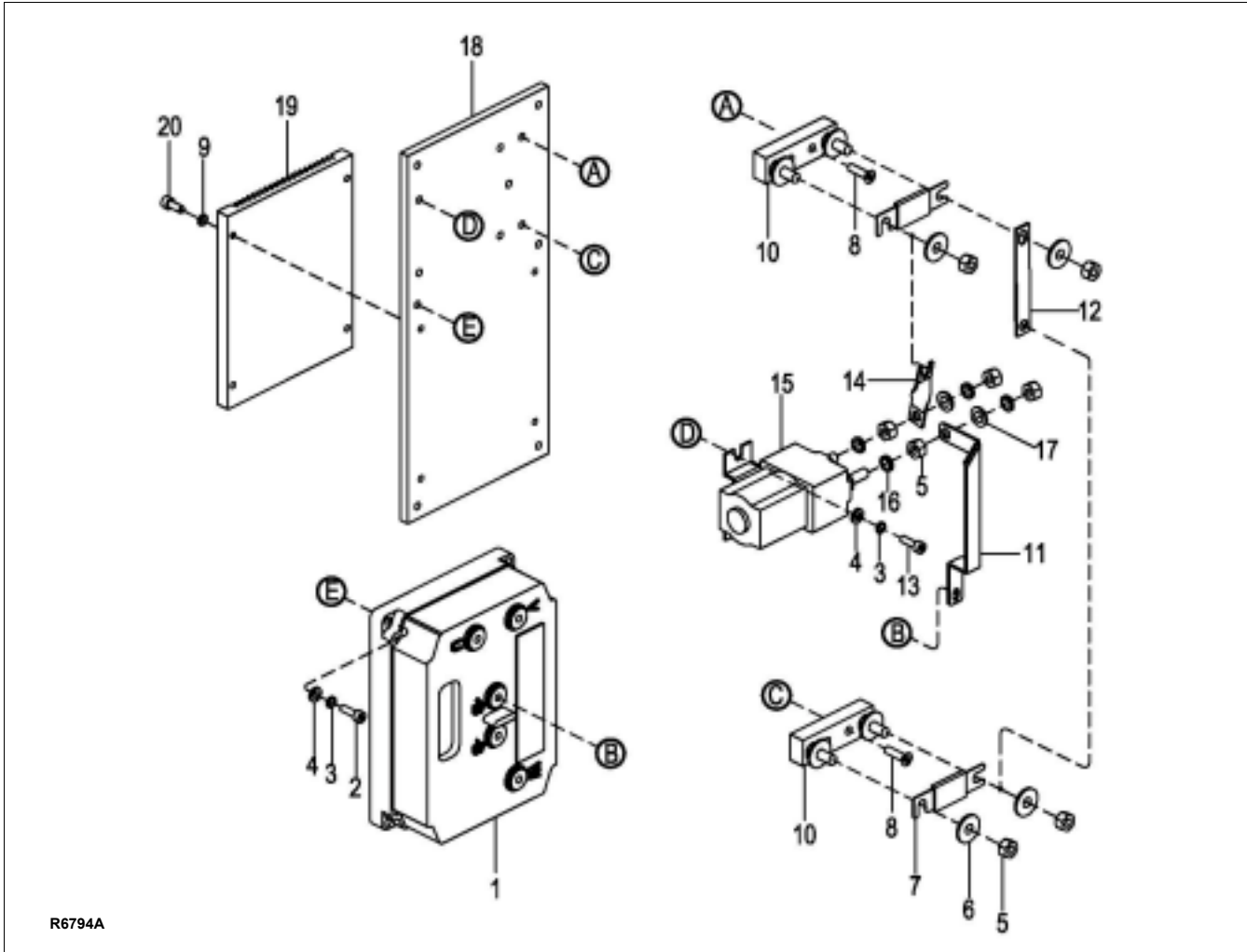

R6794A

Figure 12-14 Electrical Panel

| INDEX NO. | PART NO. | PART NAME | NO. REQD. |
|-----------|------------------|--------------------|-----------|
| — | 1280-520000-00 | ELECTRICAL PANEL | 1 |
| 1 | 1280-560001-00 | • CONTROLLER | 1 |
| 2 | 0000-000074-00 | • SCREW, M6 X 20 | 4 |
| 3 | 0000-000056-00 | • WASHER, LOCK, M6 | 6 |
| 4 | 0000-000380-00 | • WASHER, FLAT, M6 | 6 |
| 5 | 0000-000196-00 | • NUT, M8 | 12 |
| 6 | 0000-000210-00 | • WASHER, FLAT, M8 | 8 |
| 7 | 1120-540002-00 | • FUSE, 200A | 2 |
| 8 | 0000-000126-00 | • SCREW, M6 X 16 | 4 |
| 9 | 0000-000206-00 | • WASHER, LOCK, M5 | 4 |
| 10 | 1120-540001-00-B | • FUSE BLOCK | 2 |

| INDEX NO. | PART NO. | PART NAME | NO. REQD. |
|-----------|----------------|--------------------|-----------|
| 11 | 1280-510002-00 | • BUSS BAR | 1 |
| 12 | 1280-510001-00 | • BUSS BAR | 1 |
| 13 | 0000-000015-00 | • SCREW, M6 X 10 | 2 |
| 14 | 1120-530006-00 | • BUSS BAR | 1 |
| 15 | 1280-530003-00 | • CONTACTOR | 1 |
| 16 | 0000-000159-00 | • WASHER, LOCK, M8 | 4 |
| 17 | 0000-000176-00 | • WASHER, FLAT, M8 | 2 |
| 18 | 1280-510000-00 | • BOARD | 1 |
| 19 | 1280-510004-00 | • HEATSINK | 1 |
| 20 | 0000-000004-00 | • SCREW, M5 X 12 | 4 |

NOTES

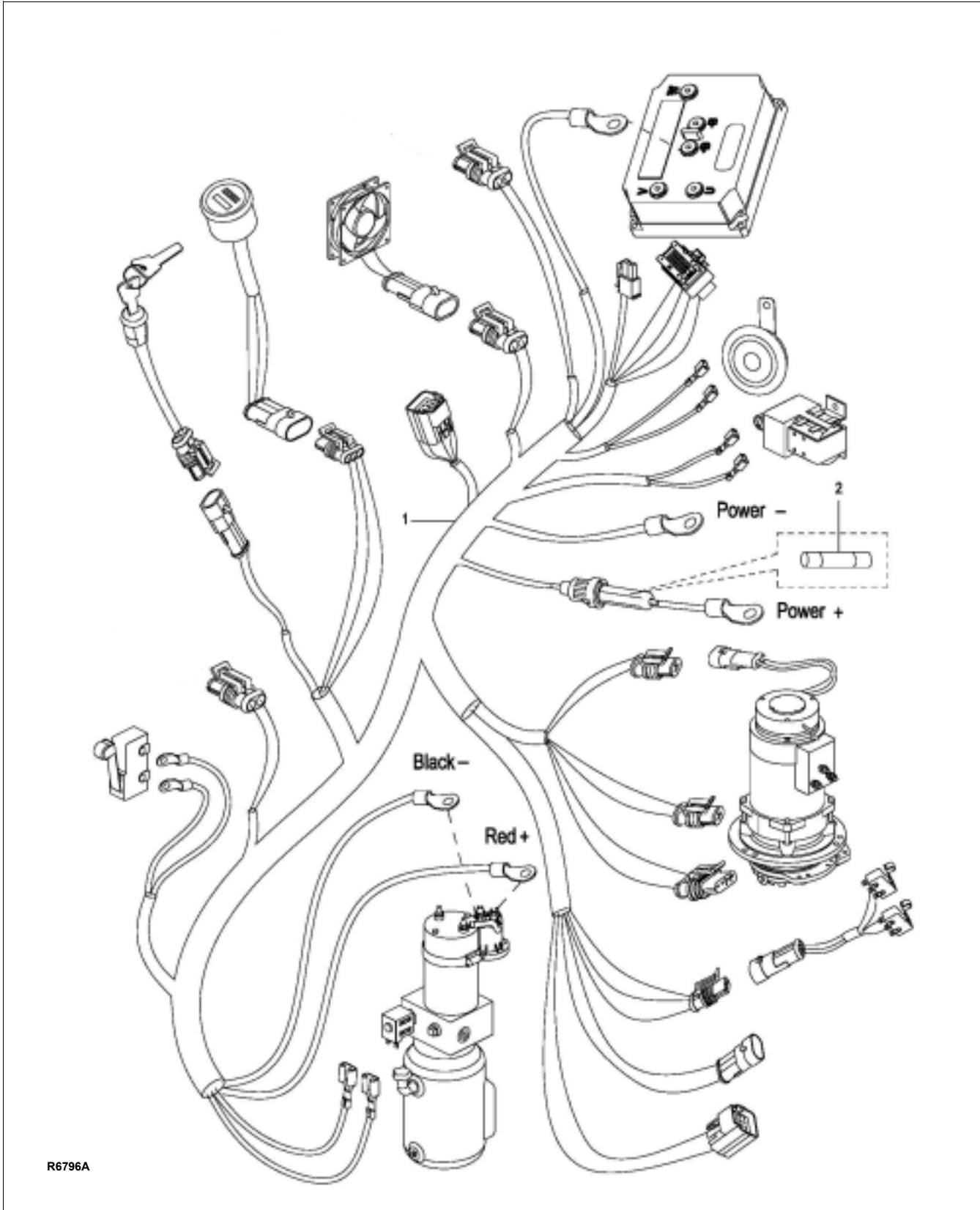

R6796A

Figure 12-15 Wiring Harness

| INDEX NO. | PART NO. | PART NAME | NO. REQD. |
|------------------|-----------------|----------------------|------------------|
| 1 | 1280-520001-00 | WIRING HARNESS, MAIN | 1 |
| 2 | 1120-500010-00 | FUSE, 10A | 1 |

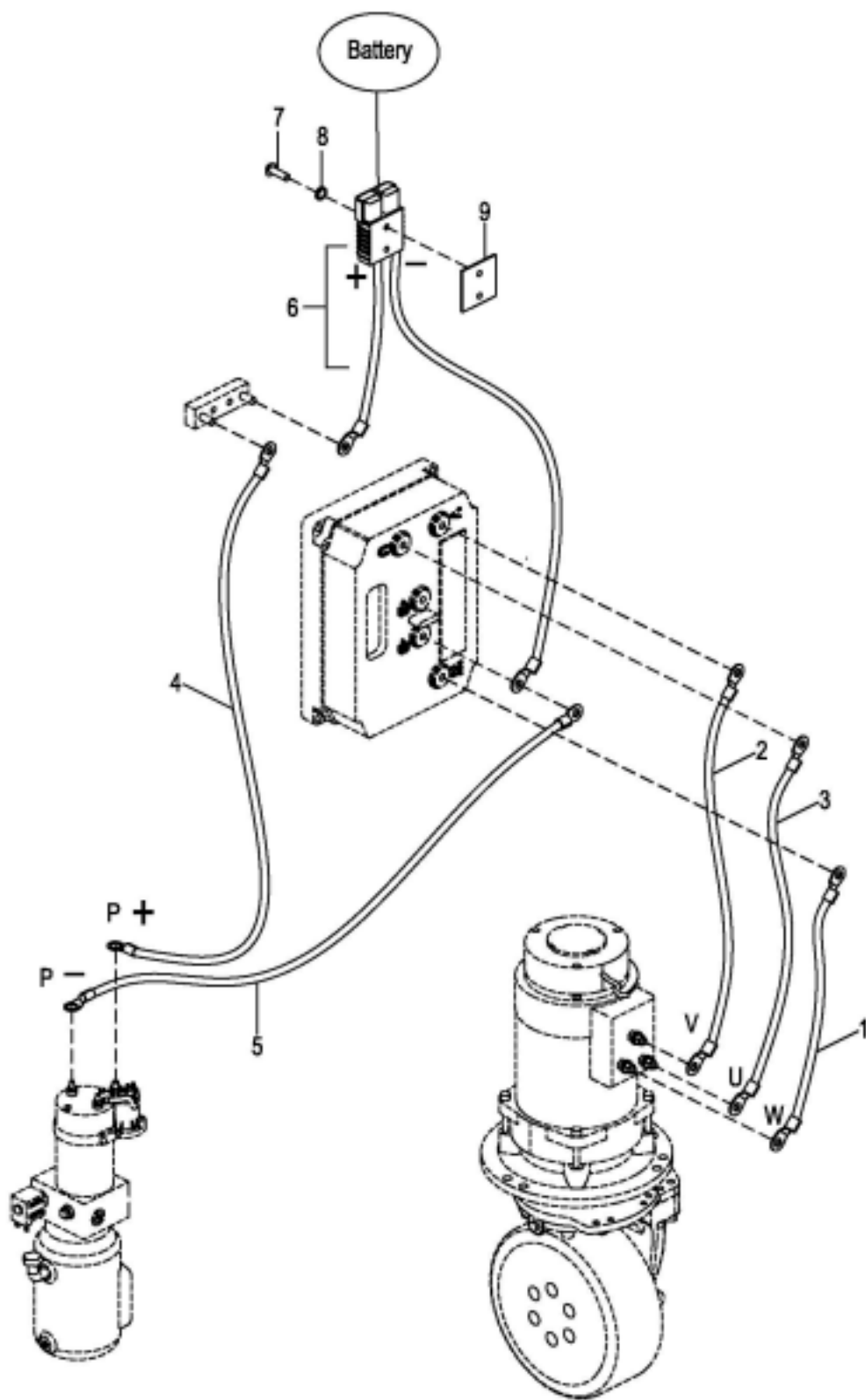

R6798A

Figure 12-16 Wiring Cables

| INDEX NO. | PART NO. | PART NAME | NO. REQD. |
|-----------|----------------|---------------------|-----------|
| 1 | 1280-531003-00 | DRIVE MOTOR CABLE W | 1 |
| 2 | 1280-531002-00 | DRIVE MOTOR CABLE V | 1 |
| 3 | 1280-531001-00 | DRIVE MOTOR CABLE U | 1 |
| 4 | 1280-531004-00 | PUMP POWER CABLE + | 1 |
| 5 | 1280-531005-00 | PUMP POWER CABLE - | 1 |

| INDEX NO. | PART NO. | PART NAME | NO. REQD. |
|-----------|----------------|------------------------|-----------|
| 6 | 1280-531100-00 | CONNECTOR BATTERY GRAY | 1 |
| 7 | 0000-000498-00 | SCREW, M6 X 30 | 2 |
| 8 | 0000-000056-00 | WASHER, LOCK, M6 | 2 |
| 9 | 1120-112008-00 | PLATE | 1 |

NOTES

BLUE GIANT[®]
BLUE GIANT EQUIPMENT CORPORATION

Corporate 410 Admiral Blvd
Mississauga, ON, Canada L5T 2N6
t 905.457.3900 f 905.457.2313

USA 6350 Burnt Poplar Road
Greensboro, NC 27409
www.bluegiant.com