

BGL-30/35

Counterbalanced Walkie Stackers with power steering.

CAPACITY

- 3,000 lbs. & 3,500 lbs. at 24" load center

BATTERY

- Compartment: 33" x 9.06/13.25" x 24"
- SB 175 Red—A-15 Connector
- Minimum battery weight 340 lbs.

SPEED

- 24-volt ZAPI travel controller
- Separate power steering controller

TRAVEL

- **EMPTY:** 0 - 3.2 mph (5.5 kph)
- **LOADED:** 0 - 3.0 mph (5 kph)

LIFT

- **EMPTY:** up to 36 fpm
- **LOADED:** up to 26 fpm

LOWERING

- **EMPTY:** up to 32 fpm
- **LOADED:** up to 36 fpm loaded

TILT

- **BACK:** 7.5°
- **FORWARD:** 2.7°

TIRES / WHEELS

- **DRIVE:** 10" x 4.1" (254 x 104 mm) polyurethane
- **LOAD:** 10" x 3.9" (254 x 102 mm) polyurethane

HYDRAULICS

- Lift cylinder is hard chrome. Self contained hydraulic power unit. Pressure compensated lowering valves regulates lowering speeds.

ELECTRICAL

- Infinitely variable travel controller and AC drive motor provides high torque through-out the entire drive range. Regenerative braking and brushless AC motor design drastically reduces maintenance.
- Travel speed remains constant relative to throttle position regardless of the load on truck. EPD emergency power disconnect shuts off all power to the system when activated and can be reset with a simple twist. A key switch is provided to limit access to approved personnel.

BRAKES

- Electromagnetic brake is mounted on the motor armature shaft multiplying the braking power through the transmission
- Brake is applied when control arm is in the vertical or horizontal handle position. Travel speed is reduced when forks are above basic carry height for transport. Position hold resists roll back on ramps.



OPERATION / CONTROLS

- Travel, lift, lower and tilt functions are located in the ergonomic operator handle designed to allow operation with either hand. Lift and lower controls are fully proportional. Wrap around hand guard, reversing switch, dual butterfly thumb controls, and horn are standard.

TRANSMISSION

- Vertically mounted drive motor is direct mounted to gear housing. Oil bathed bevel gear drive-train transfers power to axle. State of the art optimized gear technology supplies advantages such as zero maintenance, low noise level, high efficiency and high performance.

FRAME AND MAST

- Compact heavy duty design with cast counterweight and high ground clearance. Bolt-on high visibility I-beam construction, lift cylinders are positioned inline with outer I-beam. Dual lifting chains. Class two ITA fork carriage with 36" tall load back rest.

ACCESSIBILITY

- Removal of power head cover exposes major hydraulic and electrical components for inspection and maintenance.

BEARINGS

- **DRIVE WHEEL:** Tapered roller bearings sealed in oil bath
- **LOAD WHEELS:** Sealed ball bearings

STANDARD EQUIPMENT

- Power Steering
- Proportional Lift & Lower
- Hour Meter BDI Combo Gauge
- Key Switch
- 36" Tall Load Backrest
- 42" forks

OPTIONAL EQUIPMENT

- Sideshifter
- Wide carriage, Additional fork sizes
- 224ah AGM battery pack
- 205ah lithium battery pack
- Industrial lead acid battery & charger

SPECIFICATIONS

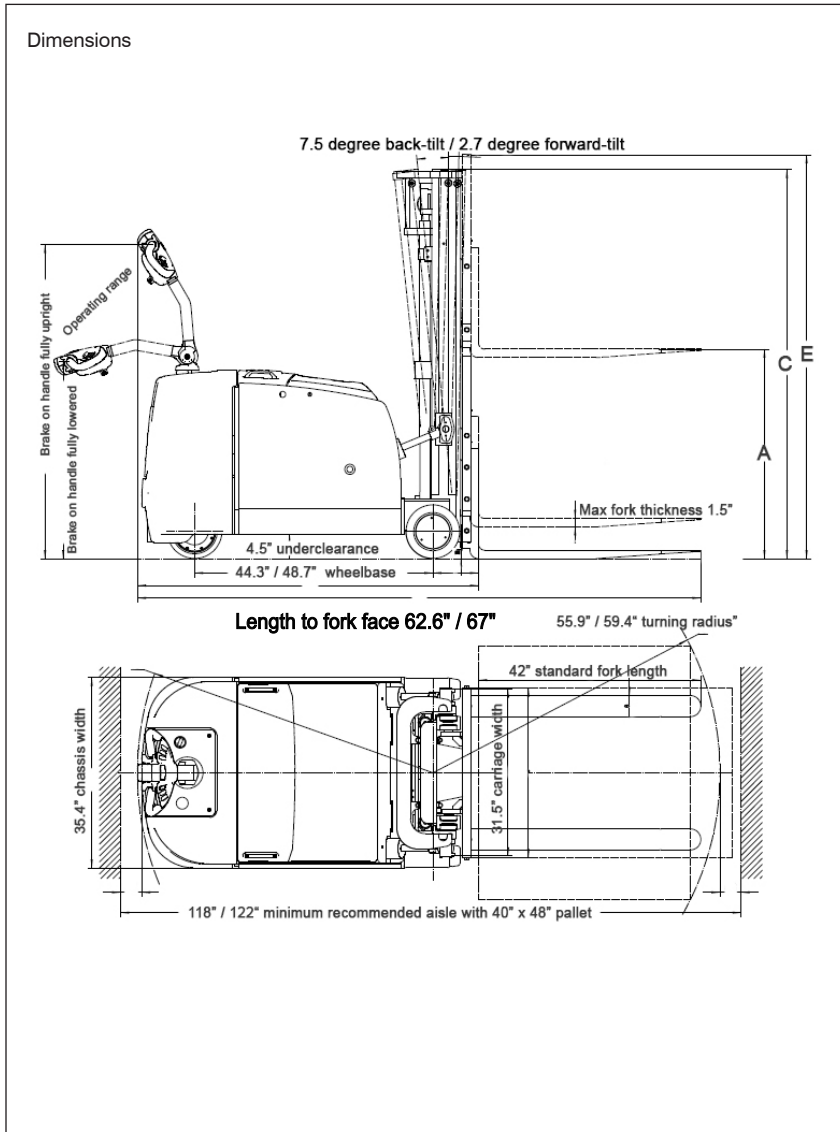

Aisle Guide
BGL-30 Right Angle Stacking

Load Width	Load Length			
	36"	40"	48"	
36"	914 mm	106" (2692 mm)	109" (2769 mm)	117" (2972 mm)
40"	1016 mm	107" (2718 mm)	110" (2794 mm)	118" (2997 mm)
48"	1219 mm	109" (2769 mm)	112" (2845 mm)	119" (3023 mm)

For ease of use add 6 to 12" to aisle dimension listed add 4" to values for BGL35 model

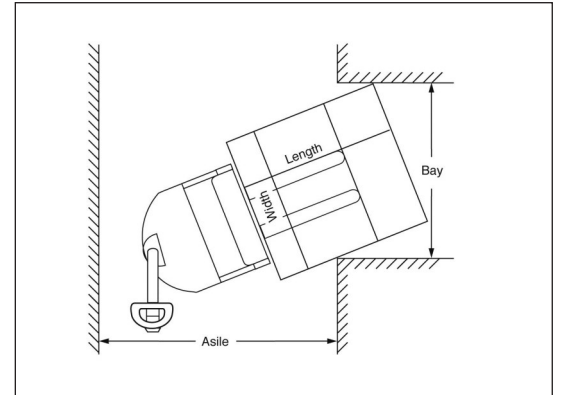

Note: Aisle dimensions listed above assume the larger dimension; load width or load length. For ease of use add 6" to 12" for operator clearance to the appropriate specifications listed above. Truck performance may vary due to application requirements and changes in model design.



Model #	Mast	Lift Height	Col Height	Free Lift	Ext Height w/LBR	Gradability		³ Weight Chassis Only
		A	C	D	E	Loaded	Unloaded	
3000lbs. Capacity @ 24" Load Center ITA Class II Fork Carriage								
BGL-30-104	Two Stage	104	72.4	5.9	140	5%	8%	4532
BGL-30-126	Two Stage	126	83.4	5.9	162	5%	8%	4598
BGL-30-157*	Triple Stage	157	71.75	52	193.5	5%	8%	4895

*Derate 200 lbs. above 126", additional derate with sideshift option

³ Estimated shipping weight without battery

Model #	Mast	Lift Height	Col Height	Free Lift	Ext Height w/LBR	Gradability		³ Weight Chassis Only
		A	C	D	E	Loaded	Unloaded	
3500lbs. Capacity @ 24" Load Center ITA Class II Fork Carriage								
BGL-35-104	Two Stage	104	72.4	5.9	140	5%	8%	4620
BGL-35-126	Two Stage	126	83.4	5.9	162	5%	8%	4686
BGL-35-157*	Triple Stage	157	71.75	52	193.5	5%	8%	4983

*Derate 200 lbs. above 126", additional derate with sideshift option

³ Estimated shipping weight without battery

BLUE GIANT
BLUE GIANT EQUIPMENT CORPORATION

Corporate 410 Admiral Blvd
Mississauga, O , Canada L5T 2 6
t 905.457.3900 f 905.457.2313

USA 6350 Burnt Poplar Road
Greensboro, NC 27409
www.BlueGiant.com

AUTHORIZED DEALER

Blue Giant offers a full line of dock levelers, dock safety equipment, seals and shelters, accessories, ergonomic and scissor lift equipment and industrial trucks. Concurrent with our continuing product improvement program, specifications are subject to change without notice. Please contact Blue Giant for latest information. Some features illustrated may be optional in certain market areas.