

Energy Products Survey



DATE: _____

SITE DATA

COMPANY:	NAME:	ADDRESS:
COUNTRY:	CITY:	STATE/ PROVINCE:
CONTACT:	CONTACT'S EMAIL:	NUMBER OF POSITIONS / BAYS:
YEAR BUILT:	BUILDING USE AND/OR FUNCTION:	

REPORTER DATA

NAME:	EMAIL:	COMPANY:
-------	--------	----------

DIRECTIONS

1. Please complete all questions applicable to the installation configuration. Failure to supply required information may result in a delay in your order processing. Survey information must reflect site conditions at the time of installation
2. For multiple positions / bays: If site conditions are not identical for each position / bay, please fill out a separate site survey form.
3. To ensure accurate order processing, please use decimals instead of fractions when supplying dimensions and other measurements (for example 1/2" should be .50")
4. Use either imperial (e.g. lb, in) or metric (e.g. kg, mm) units of measurement consistently throughout the document.

NOTES

DOCK INFORMATION

CLEARANCE BETWEEN DOCK AND PIT WALL (MEASURE BOTH SIDES)

- OVER 1" (STANDARD) UNDER 1" (LOW PROFILE)

BRAND

- BLUE GIANT OTHER

TYPE

- MECHANICAL HYDRAULIC AIR

MODEL

SERIAL NUMBER

PIT DIMENSIONS

W	L
---	---

Width measurement required to determine rear seal dimensions. Although rear seal is included as standard, proper application may be inconsistent with certain dock brands.

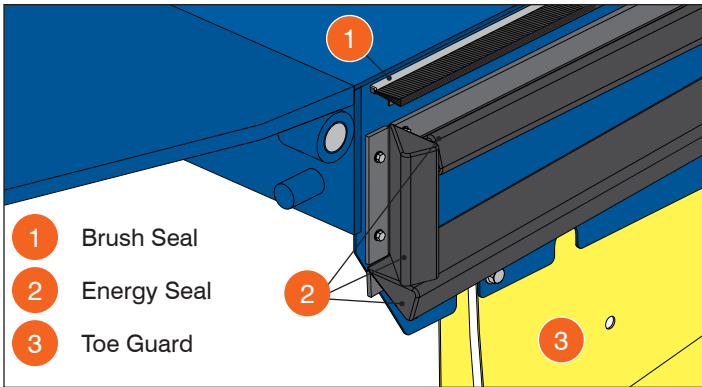
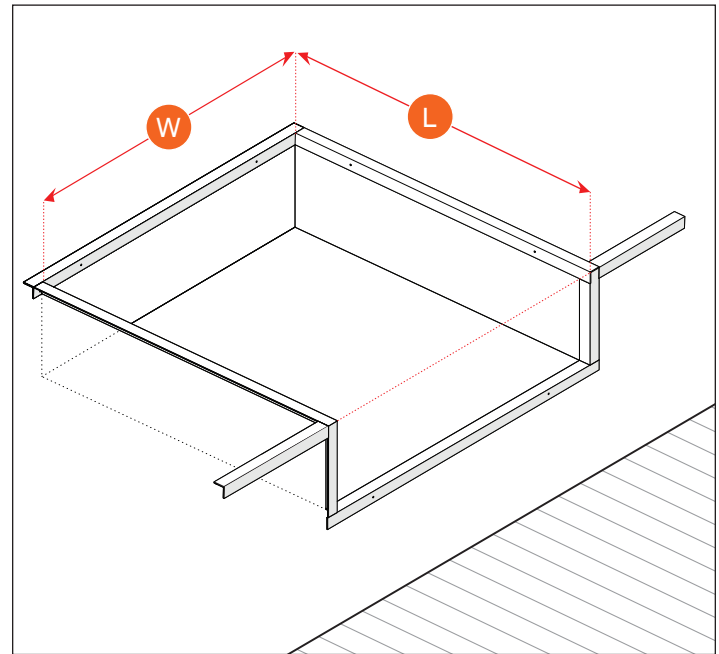

Figure 1

NOTES

Energy Seal comes with 1 - 1.5" (25-38 mm) brush weatherseal for standard profile kits and 3/4" - 1" (19-25 mm) for low profile kits. Kit provided is determined by clearance between toe guards (on each side of leveler) and pit wall. If clearance dimensions are not equal on both sides, it is recommended that the leveler be adjusted until both sides are an equal distance from the pit wall.

Energy seal can only be installed on docks where the telescopic toe guards are mounted on the inside of the dock (Figure 1).